

climaVAIR

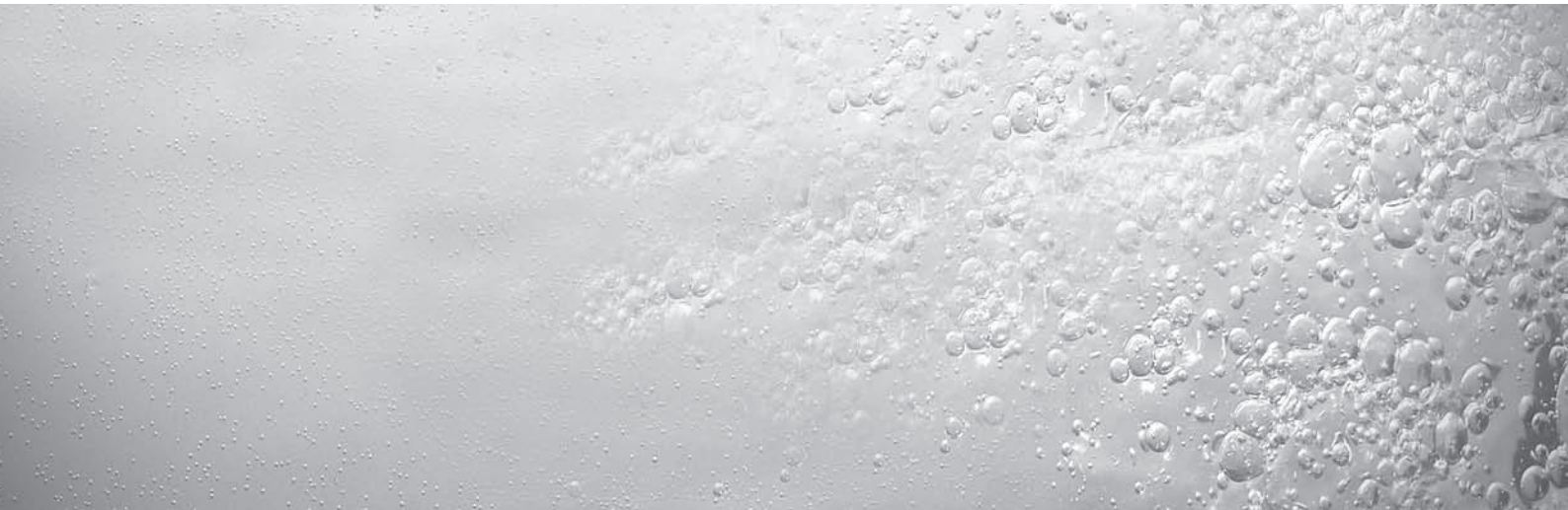

VA 6-035 MXNHKI  
VA 6-050 MXNHKI

For the user

User Manual

# Air Conditioner - climaVAIR

Multi Split Type

VA 6-035 MXNHKI

VA 6-050 MXNHKI

# Contents

## Contents

<b>1</b>	<b>Your Safety</b> .....	<b>3</b>	<b>8</b>	<b>Advice for saving Energy</b> .....	<b>20</b>
1.1	Symbols used .....	3	8.1	Suitable ambient Temperature .....	20
1.2	Proper Use of the Unit .....	3	8.2	Eliminating Heat or Cold Sources .....	20
<b>2</b>	<b>Extreme Operating Conditions</b> .....	<b>3</b>	8.3	Operation in Heating Mode (Heat Pump) .....	20
<b>3</b>	<b>Identification of the Unit</b> .....	<b>4</b>	8.4	Ambient Temperature when absent .....	20
<b>4</b>	<b>Declaration of Conformity</b> .....	<b>4</b>	8.5	Uniform Heating .....	20
<b>5</b>	<b>Description of the Unit</b> .....	<b>4</b>	8.6	Reduction in Consumption during Night Hours (SLEEP Function) .....	20
5.1	Remote Controller .....	4	8.7	Reduction in Consumption with programmed Operating Time (TIMER Function) .....	20
5.2	Technical Specifications .....	5	8.8	Appropriate Maintenance of the Unit .....	20
<b>6</b>	<b>Initial Settings</b> .....	<b>6</b>	<b>9</b>	<b>Communication between the Indoor and Outdoor Units</b> .....	<b>21</b>
6.1	Fitting the Remote Controller Batteries .....	6	<b>10</b>	<b>Troubleshooting</b> .....	<b>22</b>
6.2	Clock Settings .....	6	<b>11</b>	<b>Maintenance</b> .....	<b>23</b>
<b>7</b>	<b>Operating Instructions</b> .....	<b>7</b>	11.1	Cleaning the Indoor Unit .....	23
7.1	General Safety Considerations during Use .....	7	11.2	Cleaning the Air Filters .....	23
7.2	Identification of Functions .....	7	11.3	Cleaning the Outdoor Unit .....	23
7.2.1	Remote Controller Buttons .....	7	<b>12</b>	<b>Storage over a prolonged Period</b> .....	<b>24</b>
7.2.2	Display Indicators .....	8	<b>13</b>	<b>Product Decommissioning</b> .....	<b>24</b>
7.3	Advice on how to use the Remote Controller .....	8			
7.3.1	Remote Controller Lock .....	8			
7.4	Connection/Disconnection of the Unit .....	8			
7.5	Selection of the Operation Mode .....	9			
7.5.1	Automatic Mode (AUTO) .....	9			
7.5.2	Cooling Mode (COOL) .....	10			
7.5.3	Dehumidifying Mode (DRY) .....	11			
7.5.4	Fan Mode (FAN) .....	12			
7.5.5	Heating Mode (HEAT) .....	13			
7.6	Setting the Airflow Direction .....	14			
7.6.1	Vertical Airflow .....	14			
7.6.2	Horizontal Airflow .....	15			
7.7	Special Function Selection .....	15			
7.7.1	SLEEP Function .....	15			
7.7.2	TIMER ON/OFF Function (CONNECTION/DISCONNECTION USING TIMER) ..	16			
7.7.3	POWER/SOFT Function .....	17			
7.7.4	FRESH AIR Function .....	18			
7.8	Emergency Operation and Operation Test .....	19			
7.8.1	Emergency Operation .....	19			
7.8.2	Operation Test .....	19			
7.8.3	Cancellation Emergency Operation/ Emergency Test .....	19			

## 1 Your Safety

### 1.1 Symbols used



**Danger!**  
Direct danger for life and health.



**Danger!**  
Danger of electric shock.



**Warning!**  
Potentially dangerous situation for the product and the environment



**Note!**  
Useful information and indications.

### 1.2 Proper Use of the Unit

This unit has been designed and manufactured for acclimatisation purposes by means of air conditioning. The use thereof for other domestic or industrial purposes shall be the exclusive responsibility of the persons projecting, installing or using them in that way.

Prior to handling, installing, starting up, using or performing maintenance on the unit, the persons assigned to perform these tasks should be familiar with all the instructions and recommendations set forth in the unit's installation manual and in the user manual.



**Note!**  
Keep the manuals throughout the service life of the unit.



**Note!**  
The information relating to this unit is divided between two manuals: installation manual and user manual.



**Note!**  
This equipment contains R-410A refrigerant. Do not vent R-410A into atmosphere: R-410A, is a fluorinated greenhouse gas, covered by Kyoto Protocol, with a Global Warming Potential (GWP) = 1975.



**Note!**  
The refrigerant fluid contained in this equipment must be properly recovered for recycling, reclamation or destruction before the final disposal of the equipment.



**Note!**  
The relevant personnel performing the maintenance operations related with the handling of the refrigerant fluid must have the necessary certification issued by local authorities.

## 2 Extreme Operating Conditions

This unit has been designed to operate within the range of temperatures indicated on Figure 2.1. Ensure that these ranges are not exceeded.

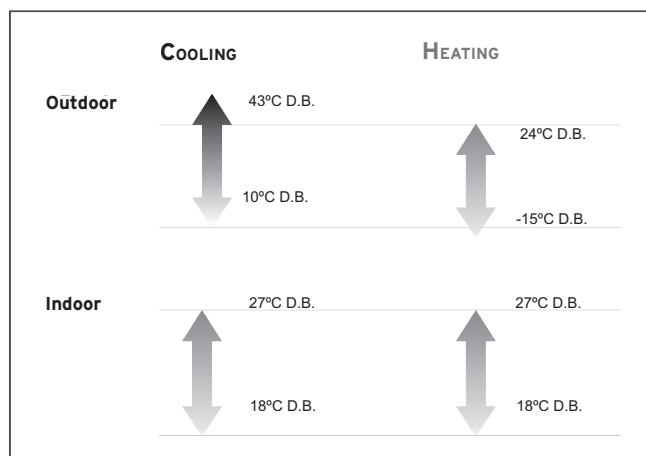

**Fig. 2.1** Operating ranges of the unit

#### Legend

D.B. Temperature measured by dry bulb

### 3 Identification of the Unit

### 4 Declaration of Conformity

### 5 Description of the Unit

#### 3 Identification of the Unit

This manual is valid for the Split Type series. In order to know the specific model of your unit please refer to the unit nameplates.

The nameplates are located on the outdoor and indoor units.

#### 4 Declaration of Conformity

The manufacturer declares that this unit has been designed and constructed in compliance with the standard in force with regard to obtaining the CE Marking.

#### 5 Description of the Unit

This unit is comprised of the following elements:

- Outdoor unit.
- Indoor unit.
- Remote controller and holder.
- Connections and channels.
- Accessories.

Figure 5.1 shows the unit components.

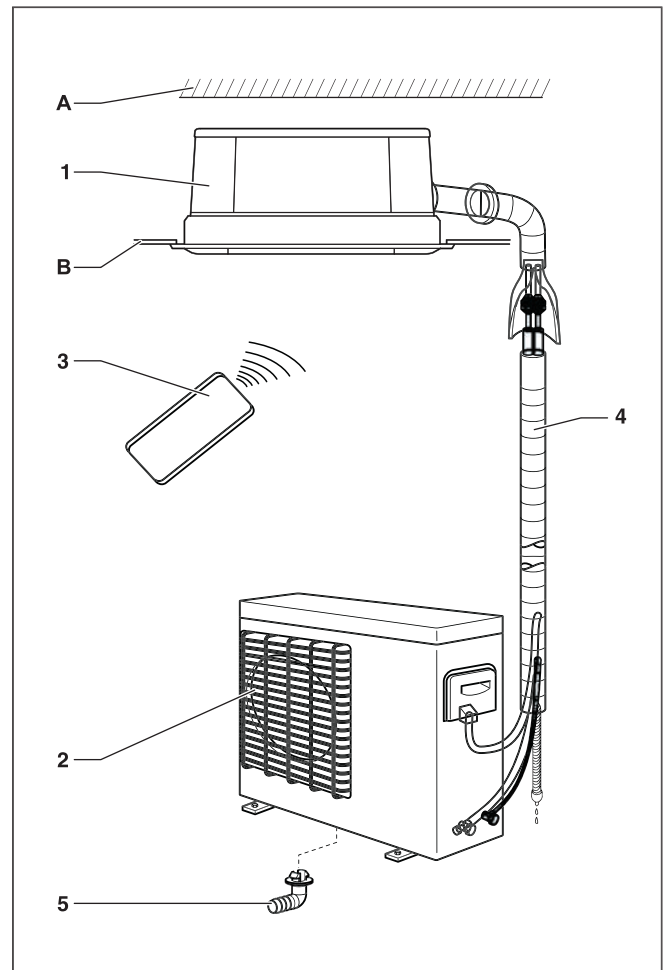

**Fig. 5.1 Unit components.**











##### Legend

- 1 Indoor Unit
- 2 Outdoor unit
- 3 Remote controller and holder
- 4 Connections and channels
- 5 Condensed water drainage pipe

#### 5.1 Remote Controller

The remote controller allows using the unit.

## 5.2 Technical Specifications

TECHNICAL SPECIFICATIONS	PICTORIAL SYMBOL	DESCRIPTION
Heat pump		The equipment is reversible. It allows cooling or heating the rooms as desired.
Refrigerant R-410A		Refrigerant free of chlorine, ecological and environmentally friendly with a transfer capacity greater than R 407 C or than R22, providing far better COP levels.
Anti-dust filter		Anti-dust filter.
Remote controller		Remote controller using infrareds. (Only for wall-type).
Hot start function		Start and stop with hot battery which avoids the discharge of cold air.
Auto restart function		After a voltage cut-off the unit's automatic restart function is guaranteed under the conditions established before the cut-off.
Class A		Maximum energetic efficiency.
Valve protection		This protects the outdoor unit's faucets from bad weather.
Anti-freeze		This prevents the freezing of the outdoor unit during the winter months.
Anti-corrosion casing		Outdoor unit made of galvanized steel and anti-corrosion materials. Resistant even in highly saline environments.

**Table 5.1 Product Features.**

## 6 Initial Settings

### 6.1 Fitting the Remote Controller Batteries

Insert the batteries R-03 (7#), as described below (see Figure 6.1).

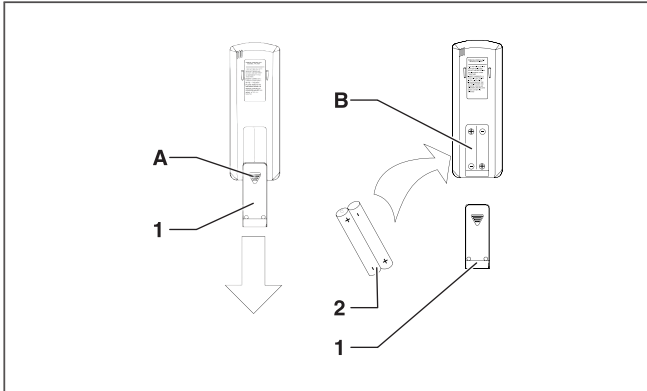

**Fig. 6.1** Fitting the remote controller batteries.

#### Legend

- 1 Battery lid
- 2 Batteries
- A Pressure area for opening the lid
- B Battery compartment

- Remove the battery lid by pressing gently on zone A and pushing the lid downwards.
- Insert the batteries in the remote control ensuring correct positive and negative polarity (Shown on the battery compartment).
- Put the lid back on.
- Press the ON/OFF button (see Figure 7.1) to check that the batteries are correctly inserted.



#### Note!

If nothing appears on the display after pressing ON/OFF, reposition the batteries.



#### Note!

Replace the two batteries at the same time.



#### Warning!

Danger of environmental contamination by not disposing of the batteries properly. When replacing the remote controller batteries, leave the old batteries in suitable containers. Never throw away in the rubbish.

### 6.2 Clock Settings

Use the remote controller to adjust the unit clock, see Figure 6.2.

- Press the CLOCK button. The "AM" or "PM" indicators start to flash on the remote controller display.
- Press the HOUR buttons to set the desired time: When pressing the HOUR buttons, the time configuration will increase or decrease by 1 minute. If the HOUR buttons are kept pressed, the time will increase or decrease rapidly.
- Press the SET button to confirm the time setting. The "AM" or "PM" indicators will stop flashing and the clock will start to operate.

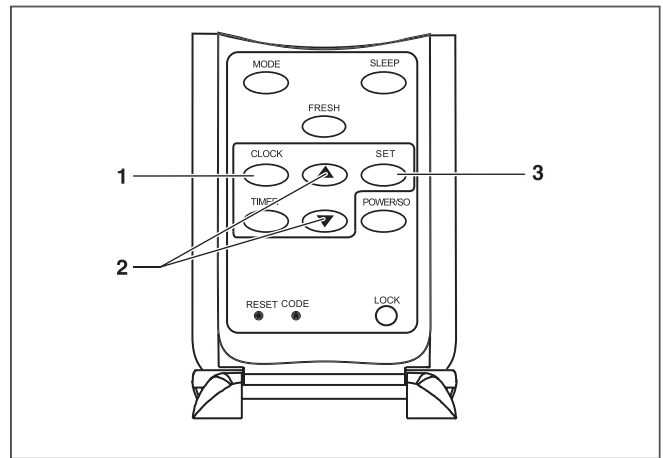

**Fig. 6.2** Clock Settings.

#### Legend

- 1 CLOCK button
- 2 HOUR button (increase/decrease)
- 3 SET button

## 7 Operating Instructions

### 7.1 General Safety Considerations during Use



**Danger of injury and physical damage!**

- Do not let children play with the air conditioning unit.  
The unit is not designed for use by children.
- Do not connect the equipment whilst using insecticides or pesticides. These could settle in the unit and harm the health of persons with allergies to specific chemical substances.
- Avoid prolonged exposure to cooled air or extreme temperatures in the room. This could be a health hazard.
- Do not insert your fingers or other objects in the air inlets and outlets, or between the unit slats whilst the unit is operating. The high speed of the fan can cause injuries.



**Danger of injury and physical damage!  
Danger of fire and explosion.**

- Do not place any heat source with flame in the equipment airflow. Do not use sprays or other flammable gases near the air equipment. This could cause a fire.
- In the event that any irregularity is detected (such as a burning smell), unplug the unit from the mains immediately and contact the distributor in order to proceed properly. If you continue to use the unit under these irregular conditions, it could be damaged and cause short circuiting or fire.
- Phone a specialist technician and ensure that preventive measures are implemented to avoid refrigerant gas leaks. Leaking refrigerant of a certain density can cause oxygen deficiency.



**Danger!**  
**Danger of electric shock.**  
Do not handle the equipment with wet or moist hands.



**Warning!**  
Danger of breakdowns or malfunction.  
- Do not place any object on the outdoor unit.

### 7.2 Identification of Functions

#### 7.2.1 Remote Controller Buttons

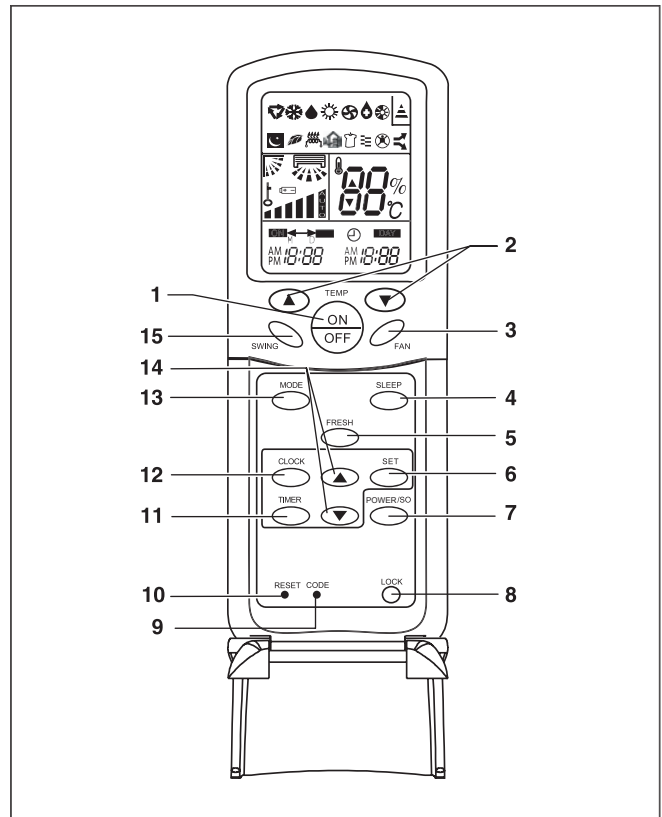

Fig. 7.1 Overview of the buttons.

**Legend**

- 1 ON/OFF Button
- 2 TEMP Button (TEMPERATURE)
- 3 FAN Button
- 4 SLEEP Button (NIGHTTIME FUNCTION)
- 5 FRESH Button (ONLY FOR FRESH AIR TYPE - VA 6-035 MXNHKI, VA 6-050 MXNHKI)
- 6 SET Button (SETTING)
- 7 POWER/SOFT Button
- 8 LOCK Button
- 9 CODE Button (THIS UNIT SHOULD BE SET TO CODE A)
- 10 RESET Button
- 11 TIMER Button
- 12 CLOCK Button
- 13 MODE Button
- 14 HOUR Button
- 15 SWING Button



**Note!**  
This remote control also includes the buttons HEALTH and FILTER, that are not activated for these models.



**Warning!**  
Make sure the unit is set to code A (if you take out the batteries). If set to code B the remote will not work.



## 7 Operating Instructions

### 7.2.2 Display Indicators

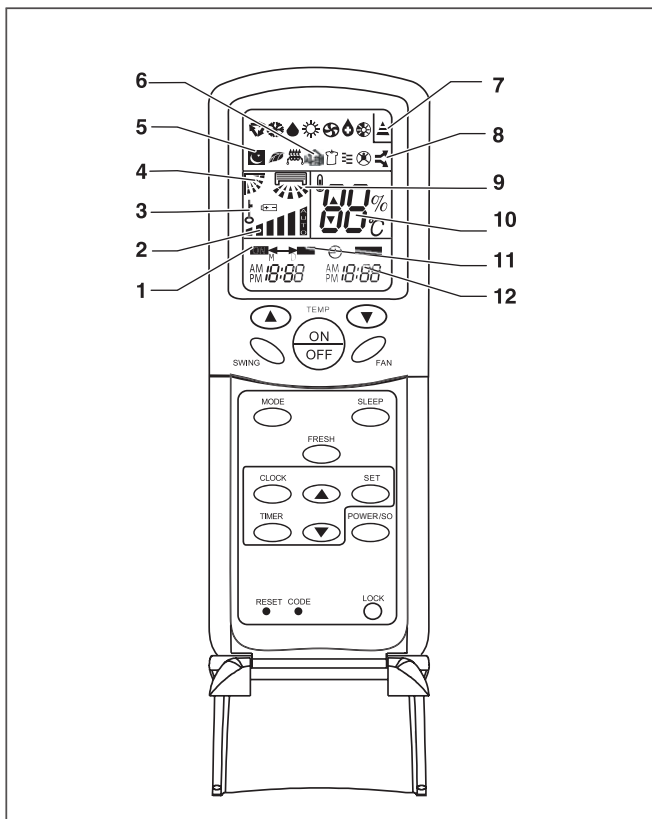

Fig. 7.2 Overview of the indicators.

#### Legend

- 1 TIMER indicator
- 2 FAN SPEED indicator
- 3 LOCK indicator
- 4 SWING UP/DOWN indicator (AIRFLOW DIRECTION UP/DOWN)
- 5 SLEEP indicator (NIGHTTIME FUNCTION)
- 6 FRESH AIR indicator
- 7 CODE indicator
- 8 POWER/SOFT indicator
- 9 AIR FLOW LEFT/RIGHT indicator
- 10 TEMP indicator (TEMPERATURE)
- 11 TIMER OFF indicator (DISCONNECTION USING TIMER)
- 12 CLOCK indicator

### 7.3 Advice on how to use the Remote Controller

Follow the recommendations below as to how to use the remote controller:

- When in use, direct the head of the signal transmitter directly to the outdoor unit receiver.
- Keep the distance between the transmitter and the receiver within 7 m.
- Avoid obstacles between the transmitter and the receiver.
- Reduce the distance between the remote controller and the indoor unit in locations with fluorescent lights with electronic switching on or cordless telephones.
- Do not drop or strike the remote controller.

#### 7.3.1 Remote Controller Lock

In order to lock the buttons and display of the remote controller device:

- Press the LOCK button.  
The rest of the buttons are deactivated.  
The lock status indicator appears.

In order to deactivate the lock:

- Press the LOCK button again.  
The rest of the buttons are activated.  
The lock status indicator disappears.

#### Note!

If the remote controller does not operate correctly, press the RESET button with a sharp object to reset the remote controller.

### 7.4 Connection/Disconnection of the Unit

In order to connect the unit:

- Press the ON button on the indoor unit or on the remote controller; the unit will start to operate.  
The liquid crystal display (LCD) will show the latest operating status of the unit (except the SLEEP, POWER/SOFT and TIMER ON/OFF functions).

In order to disconnect the unit:

- Press the OFF button on the indoor unit or on the remote controller; the unit will stop.

## 7.5 Selection of the Operation Mode

### 7.5.1 Automatic Mode (AUTO)

There are two AUTO modes: automatic and fully automatic

#### Automatic running mode

Under this mode, the MCU will choose the work mode according to the room temperature so as to keep the fixed temperature (fixed at 23°C for heating mode and 26°C for cooling mode). When the unit is powered on for the first time and the room temperature is equal to or below 23°C, it will start the heating mode or the cooling mode when the room temperature is higher than 23°C.

Enter into the heating mode and follow the heating process (fixed temperature 23°C). When the temperature is high enough to stop the compressor, the compressor stops and there will be 3 minutes of idle mode. If the compressor senses the incoming wind temperature is higher than 23°C after it stops for 15 minutes, the unit will switch to cooling mode. Otherwise it will keep the heating mode.

Enter into the cooling mode and follow the cooling process (fixed temperature 26°C). Compensation temperature difference will be cancelled automatically. When the temperature is high enough to stop the compressor, the compressor stops and there will be 3 minutes for idle mode. If the compressor senses the incoming wind temperature is equal to or below 23°C after it stops for 15 minutes, the unit will switch to heating mode. The compensation temperature will be added automatically. Otherwise it will keep the cooling mode.

When the unit switches from other modes to automatic mode, if the work state changes (judge first and then work), there will be 3 minutes for idle mode. And then the temperature will change to the judged level according to the incoming wind temperature.

#### Fully automatic mode

When the operation mode switches to automatic after the unit is powered on, the system will choose the operation mode according to the difference between the current set temperature and the room temperature. And then it will follow the selected mode to operate. The  $T_r$  represents room temperature and  $T_s$  represents the set temperature.

When entering into the automatic mode for the first time, please select the operation mode with the conditions below.

$T_r = T_s - 3$  degree, select the cooling mode

$T_r < T_s - 3$  degree, select the heating mode

The operation mode may switch between the cooling and heating according to the indoor temperature under the automatic mode. If the unit is under the cooling mode currently, when the temperature is enough for the compressor to stop, the compressor stops. After 15 minutes the compressor will detect the temperature.

If  $T_r < T_s - 3$ ., then the unit will start the heating mode, otherwise it will remain in the cooling mode. If the unit is under the heating mode currently, when the temperature is enough for the compressor to stop, the compressor stops. After 15 minutes the compressor will detect the temperature. If  $T_r > T_s - 3$ ., then the unit will start the cooling mode, otherwise it will remain in the heating mode. There is timing function and sleeping function with this mode. If the unit is under the cooling mode then it will start the cooling hibernating mode. If the unit is under the heating mode then it will start the heating hibernating mode.

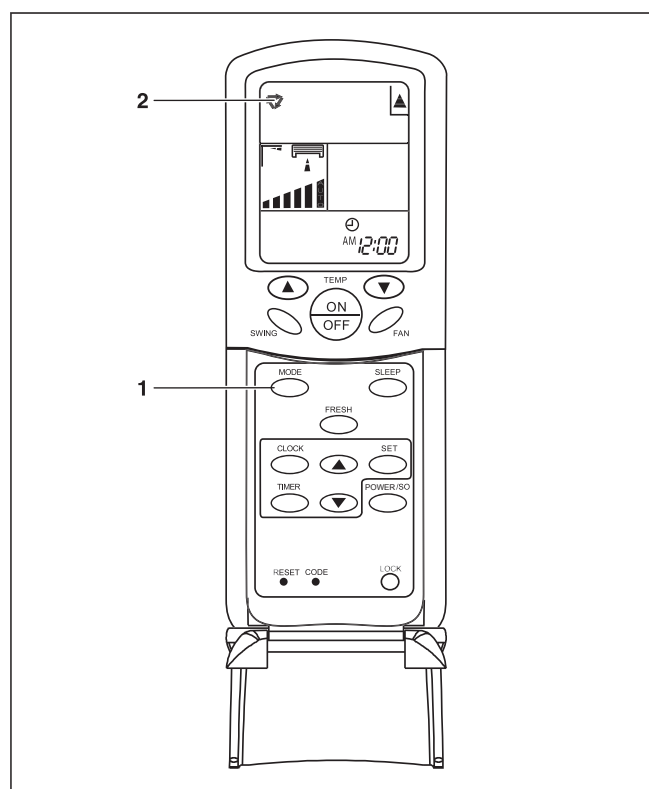

Fig. 7.3 Automatic mode selection.

#### Legend

- 1 MODE button
- 2 AUTO mode indicator

In order to activate:

With the unit connected (see section 7.4):

- Press the MODE button.
- The different operation modes are displayed.



Fig. 7.4 Operation modes.

- Select the automatic operation mode (AUTO).



#### Warning!

In auto mode you can not set the temperature.

## 7 Operating Instructions

### 7.5.2 Cooling Mode (COOL)

In cooling mode (COOL), the air conditioning unit only allows cooling.



**Note!**

In cooling mode it is recommendable to direct the grates horizontally.

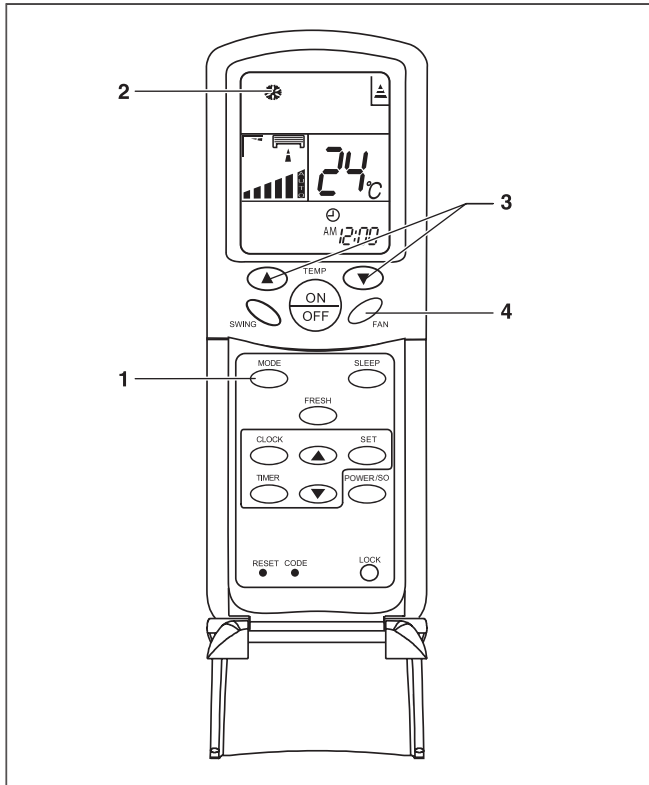

Fig. 7.5 Cooling mode selection.

**Legend**

- 1 MODE button
- 2 COOL mode indicator
- 3 TEMP button (increase/decrease)
- 4 FAN button

In order to activate:

With the unit connected (see section 7.4):

- Press the MODE button.  
The different operation modes are displayed.



Fig. 7.6 Operation modes.

- Select the cooling operation mode (COOL).
- Press the TEMP buttons to select the temperature setting.

When pressing the TEMP buttons, the temperature configuration will increase or decrease by 1°C. When keeping the TEMP buttons pressed, the temperature configuration will increase or decrease quickly.

- Press the FAN button to select the fan speed. Each time the FAN button is pressed, the fan speed will be modified as shown in Figure 7.7.



Fig. 7.7 Fan speed.

When the fan is configured in AUTO mode, the air conditioning unit automatically sets the fan speed in accordance with the actual ambient temperature.



**Note!**

In cooling mode, prolonged use of the unit under conditions of considerable air humidity can cause drops of water to fall on the outlet grate.

**7.5.3 Dehumidifying Mode (DRY)**

In dehumidifying mode (DRY), the air conditioning unit operates by removing the humidity from the atmosphere.

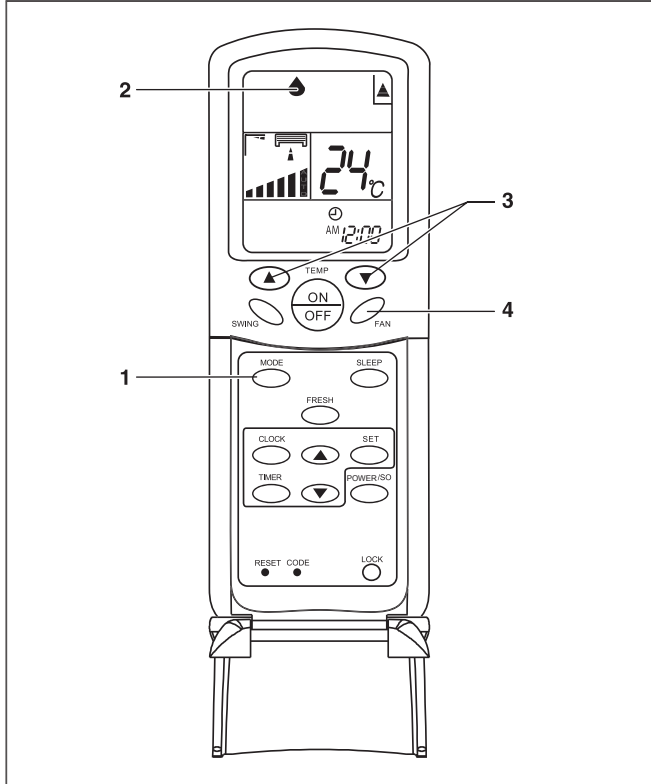

**Fig. 7.8 Dehumidifying mode selection.**

**Legend**

- 1 MODE button
- 2 DRY mode indicator
- 3 TEMP button (increase/decrease)
- 4 FAN button

In order to activate:

With the unit connected (see section 7.4):

- Press the MODE button.  
The different operation modes are displayed.



**Fig. 7.9 Operation modes.**

- Select the dehumidifying mode (DRY).
- Press the TEMP buttons to select the temperature setting.  
When pressing the TEMP buttons, the temperature configuration will increase or decrease by 1°C. When keeping the TEMP buttons pressed, the temperature configuration will increase or decrease quickly.
- Press the FAN button to select the fan speed.  
Each time the FAN button is pressed, the fan speed will be modified as shown in Figure 7.10.



**Fig. 7.10 Fan speed.**

The operation in cooling mode is started when the ambient temperature is greater than the configured one. In dehumidifying mode and, when the ambient temperature exceeds the configured one by 2°C, the unit will operate intermittently at LOW speed regardless of the fan configuration, see Figure 7.11.

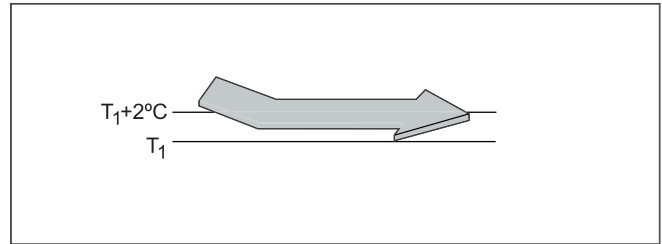

**Fig. 7.11 Dehumidifying mode working diagram.**

**Legend**

T<sub>1</sub> Configured temperature



**Note!**

In dehumidifying mode, prolonged use of the unit under conditions of considerable air humidity can cause drops of water to fall on the outlet grate.

## 7 Operating Instructions

### 7.5.4 Fan Mode (FAN)

In fan mode (FAN) the unit does not operate in the following modes:

- cooling mode (COOL).
- heating mode (HEAT).
- automatic mode (AUTO).

In fan mode (FAN) the temperature configuration and the SLEEP function are disabled.

- Select the fan operation mode (FAN).
- Press the FAN button to select the fan speed. Each time the FAN button is pressed, the fan speed will be modified as shown in Figure 7.14.



Fig. 7.14 Fan speed.

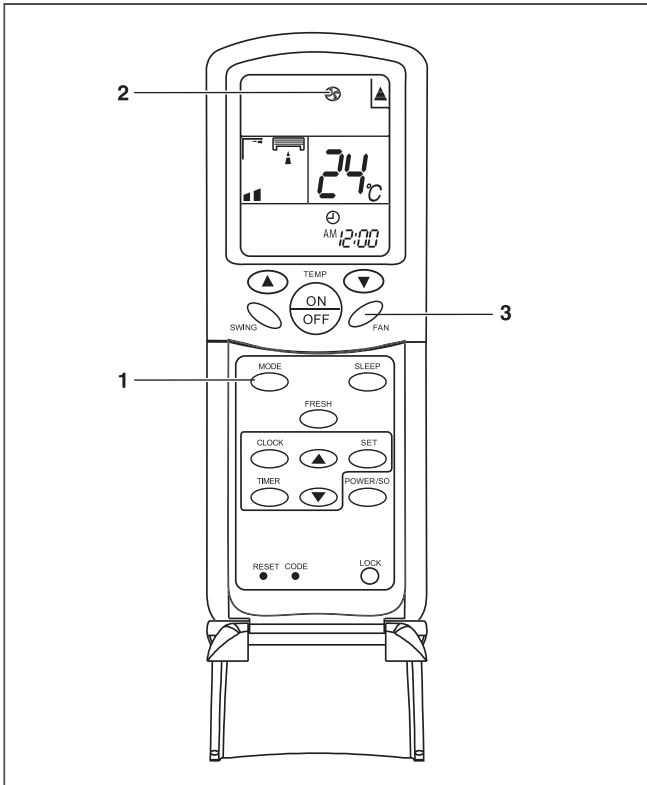

Fig. 7.12 Fan selection mode.

#### Legend

- 1 MODE button
- 2 FAN mode indicator
- 3 FAN button

In order to activate the fan mode (FAN):

With the unit connected (see section 7.4):

- Press the MODE button. The different operation modes are displayed.



Fig. 7.13 Operation modes.

## 7.5.5 Heating Mode (HEAT)

In heating mode, the air conditioning only allows heating.

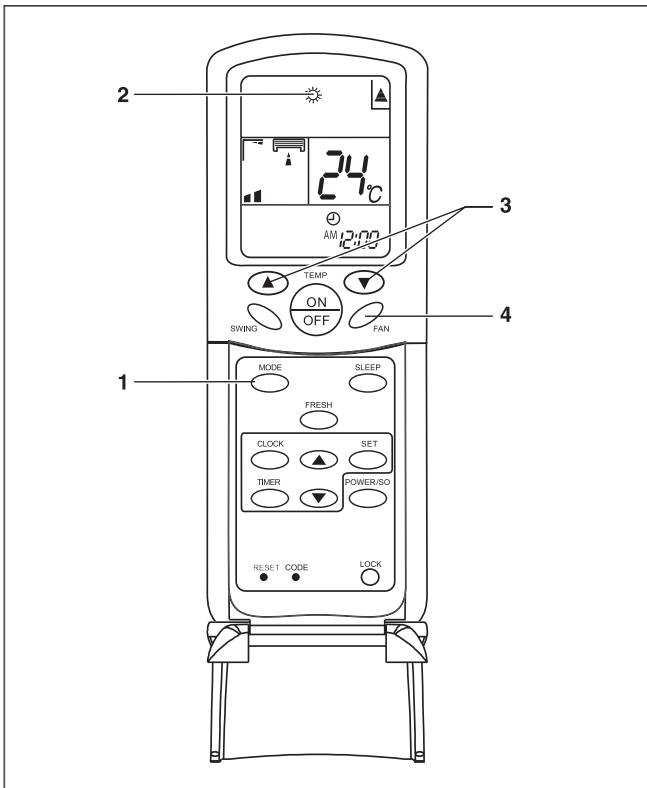

**Fig. 7.15 Heating mode selection.**

### Legend

- 1 MODE button
- 2 HEAT mode indicator
- 3 TEMP button (increase/decrease)
- 4 FAN button

In order to activate:

With the unit connected (see section 7.4):

- Press the MODE button.
- The different operation modes are displayed.



**Fig. 7.16 Operation modes.**

- Select the heating operation mode (HEAT).
- Press the TEMP buttons to select the temperature setting.

When pressing the TEMP buttons, the temperature configuration will increase or decrease by 1°C.

When keeping the TEMP buttons pressed, the configured temperature will increase or decrease quickly.

- Press the FAN button to select the fan speed. Each time the FAN button is pressed, the fan speed will be modified as shown in Figure 7.17.

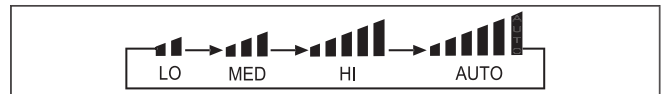

**Fig. 7.17 Fan speed**



### Note!

In heating mode (HEAT), the hot air will stop after a short period of time as a result of the function for the prevention of cold currents.



### Note!

In the defrosting function, the value of the indoor temperature shown can be reduced if the cooling mode is activated for a prolonged period.



### Note!

In heating mode it is recommendable to direct the grates vertically.

## 7 Operating Instructions

### 7.6 Setting the direction of the airflow

The direction of the airflow can be set in vertical and horizontal directions.



**Danger of injury and physical damage!**

**Avoid direct body contact with the powerful airflows. Do not expose animals and plants directly to the airflow. They could suffer damage.**

---



**Warning!**

Danger of breakdowns or malfunction.  
Do not open the outlet grate manually.

---



**Note!**

If the grate does not work correctly, stop the unit for one minute and restart it carrying out the settings required with the remote controller.

---



**Note!**

In heating mode it is recommendable to direct the grates vertically.

---



**Note!**

In cooling mode it is recommendable to direct the grates horizontally.

---

### 7.6.1 Vertical Airflow

- Press the SWING UP/DOWN button to direct the airflow upwards or downwards.

The vertical slat will be directed in accordance with the positions allowed for each operation mode.

On the remote controller or the control panel of the indoor unit the different icons will be shown in accordance with the operation mode, see Table 7.1.

- COOL/DRY/FAN modes:  
Permitted positions: 1, 2, 3, 4, 6
- HEAT mode:  
Permitted positions: 1, 2, 3, 4, 5, 6
- AUTO mode:  
Permitted positions: 1, 2, 3, 4, 5, 6

## 7.6.2 Horizontal Airflow

- Press the SWING button to direct the airflow to the left or right.

The deflectors are directed in accordance with the indicated positions.

On the remote controller or the control panel of the indoor unit the different icons will be shown, see Table 7.2.

Direction	
Position 1	
Position 2	
Position 3	
Position 4	
Position 5	
Position 6	
Position 7	
Position 8	

**Table 7.1** Horizontal direction positions.



### Note!

When stopping the unit, the remote controller will memorise the configured direction position, remembering this the next time it is put into operation.

## 7.7 Special Function Selection

### 7.7.1 SLEEP function

The COOL, DRY, HEAT modes can be set during the nighttime hours to avoid an excessive increase or decrease in the temperature.

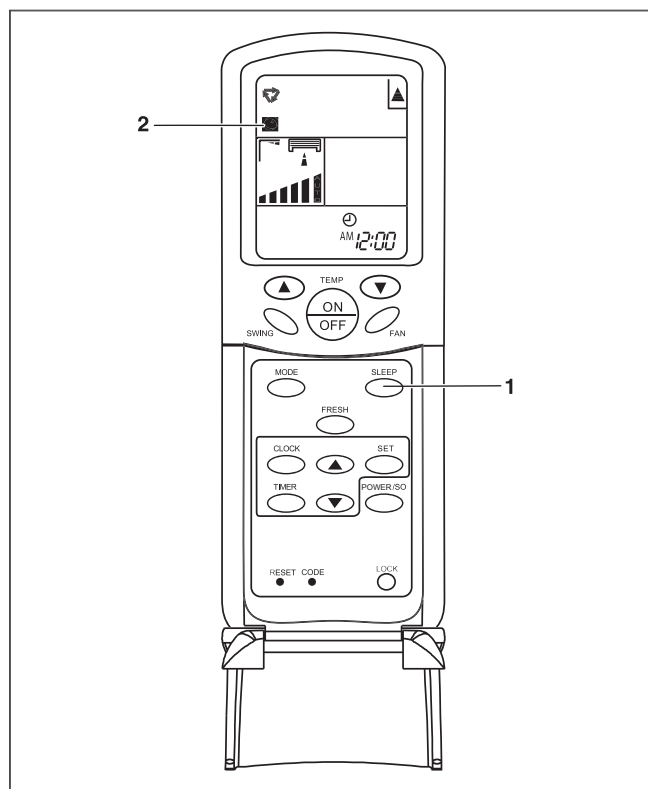

**Fig. 7.18** Selection of SLEEP function.

### Legend

- 1 SLEEP button
- 2 SLEEP function indicator

In order to activate:

- Select the desired operation mode (see section 7.5).
- Press the SLEEP button.

### In COOL, DRY mode

The ambient temperature increases 2°C in relation to the configured one to ensure that the temperature does not drop excessively during sleeping hours.

- During the first operating hour of the SLEEP function, the ambient temperature will rise 1°C above the configured temperature.
- Once an hour has elapsed, the temperature will rise 1°C more.
- The unit is operational for 6 hours before stopping.



## 7 Operating Instructions

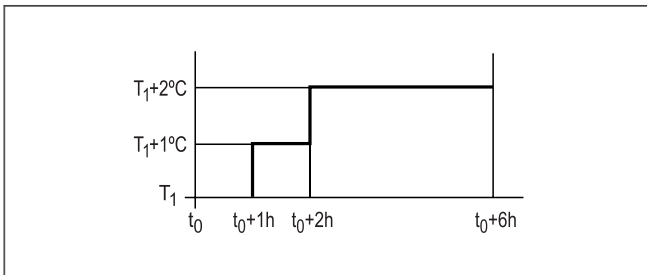

**Fig. 7.19 Working method of the SLEEP function in COOL, DRY mode.**

### Legend

$T_1$  Configured temperature  
 $t_0$  Start of the SLEEP function

### In HEAT mode

The ambient temperature decreases 2°C in relation to the configured one to ensure that the temperature does not rise excessively during the sleep hours.

- During the first operating hour of the SLEEP function, the ambient temperature will drop 2°C below the configured temperature.
- Once an hour has elapsed, the temperature will drop 2°C more.
- Once three hours have elapsed, the temperature will rise 1°C.
- The unit will be operational for a further three hours before stopping.

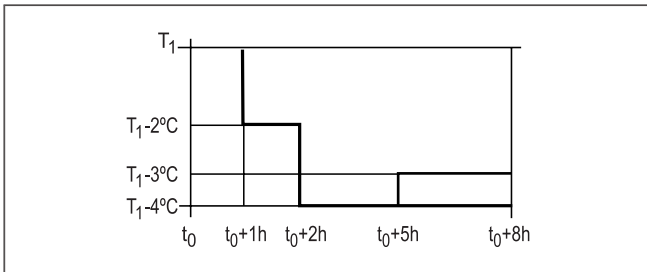

**Fig. 7.20 Working method of the SLEEP function in HEAT mode.**

### Legend

$T_1$  Configured temperature  
 $t_0$  Start of the SLEEP function

### In AUTO mode

The unit operates in the operating mode selected automatically adapted to the corresponding SLEEP modality.

### In FAN mode

The unit does not have SLEEP function.

### 7.7.2 TIMER ON/OFF Function (CONNECTION/DISCONNECTION USING TIMER)

The unit can be connected/disconnected using the timer.

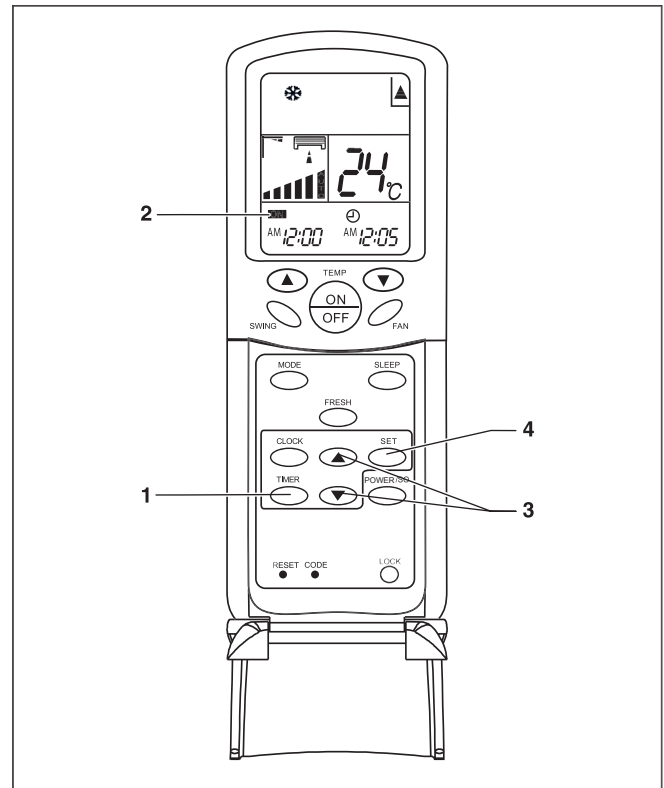

**Fig. 7.21 Selection of TIMER function.**

### Legend

- 1 TIMER button
- 2 TIMER ON/OFF function indicator
- 3 HOUR buttons (increase/decrease)
- 4 SET button

In order to activate:

- Select the desired operation mode (see section 7.5).
- Press the TIMER button. The display configuration of the remote controller will change. Each time it is pressed, the timer modality will change Timer ON/Timer OFF. The "ON"/"OFF" indicators will light.



**Fig. 7.22 Remote controller display configuration.**

- Press the HOUR buttons to programme the desired time:  
When pressing the HOUR buttons, the time configuration will increase or decrease by 1 minute. If the HOUR buttons are kept pressed, the time will increase or decrease rapidly.  
The time can be set within an interval of 24 hours.
  - Press the SET button to confirm the time.  
The "ON" or "OFF" indicators will stop flashing.  
Time display: the unit starts to operate or stops after x hours x minutes.
- In order to cancel:
- Press the TIMER button various times until the TIMER ON/OFF function display configuration disappears.

 **Note!**  
Correctly set the clock before operating the timer.

 **Note!**  
Restart the time configuration after replacing the batteries or after a possible power failure.

 **Note!**  
The unit has a memory function; when you use the TIMER ON/OFF function the next time, press the SET button if the timer configuration is identical to that used the last time.

### 7.7.3 POWER/SOFT Function

Use the POWER function when you need fast heating or cooling.  
The SOFT function will reduce the noise level of the unit.

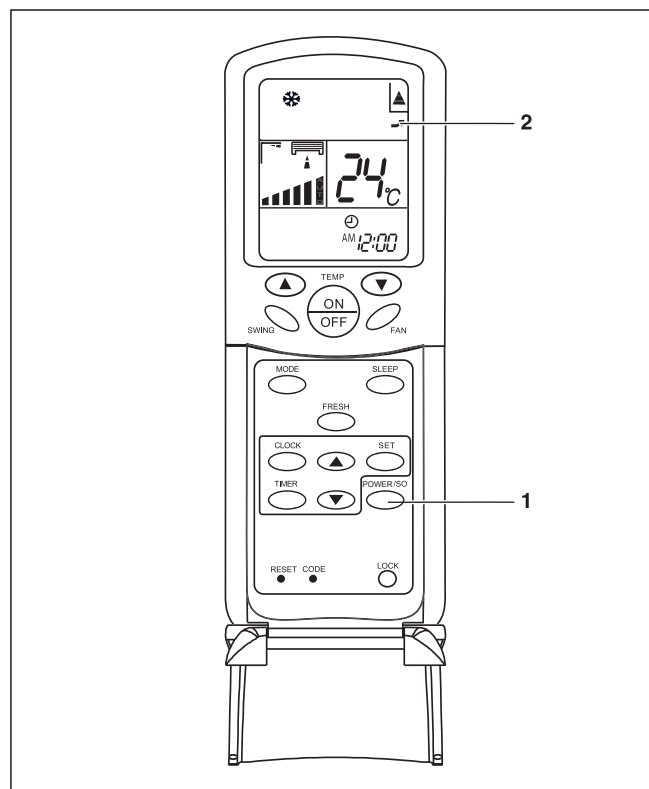

**Fig. 7.23 POWER/SOFT function selection.**

#### Legend

- 1 POWER/SOFT button
- 2 POWER/SOFT function indicator

To activate the POWER function:

- Press the POWER/SOFT button.  
Each time you press the button, you will modify the display configuration, see Figure 7.24.

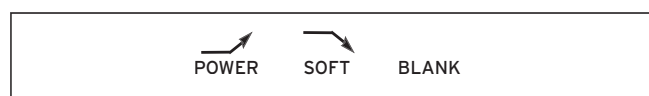

**Fig. 7.24 POWER/SOFT function display configuration.**

## 7 Operating Instructions

- Stop the display in POWER function.  
In HEAT or COOL mode the fan speed is available automatically in HI (high) for 15 minutes in order to put the configuration back to its original state.  
To cancel the POWER function:
    - Press the POWER/SOFT button twice.  
The indicator will disappear.
  - To activate the SOFT function:
    - Press the POWER/SOFT button.  
Each time you press the button, you will modify the display configuration, see Figure 7.23.
  - Stop the display in SOFT function.  
In SOFT function the fan speed is automatically available in LO (low).
- To cancel the SOFT function:
- Press the POWER/SOFT button twice.  
The indicator will disappear.

---

 **Note!**  
In POWER function in HEAT and COOL mode, the room will show an even thermal distribution.

---

---

 **Note!**  
Prolonged operation in SOFT function will cause irregularities in the atmosphere, the temperature not being too cold or too hot.

---

### 7.7.4 FRESH AIR function

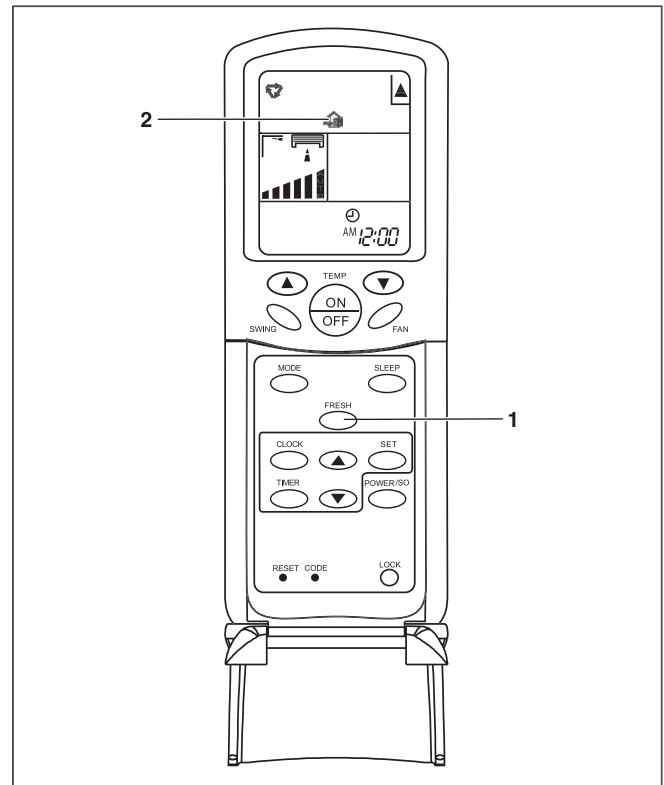

**Fig. 7.25 Selection of FRESH AIR function.**

#### Legend

- 1 FRESH AIR button
- 2 FRESH AIR function indicator

- After turning on the unit and setting the desired working mode (the remote controller LCD and control panel LCD display the working mode), press the Fresh Air button of the remote controller. The LCD displays and the unit begins continuous fresh air operation; press the button again, the indicator begins flashes and automatic fresh air operation. Press the button for the third time to cancel fresh air function. Continuous fresh air operation, i.e., if there is no intervention, the fresh air operation will run continuously and non stop. Automatic fresh air operation, i.e., the fresh air operation runs intermittently. After 20 minutes operation, the fresh air operation will stop for 20 minutes. After running for another 20 minutes, it will stop for another 20 minutes, and so on.

---

 **Note!**  
In order the system to work with Fresh Air function, the corresponding installation should be done.

---

## 7.8 Emergency Operation and Operation Test

### 7.8.1 Emergency Operation

Only use this function when the remote controller is broken or has been mislaid. In emergency operation the unit automatically selects the operation modes, Cooling or Heating depending on the ambient temperature, see Table 7.2.

Temperature	Operation Mode	Desired Temp.	Timer Mode	Airflow
> 23°C	Cooling	26°C	No	Auto
< 23°C	Heating	23°C	No	Auto

Tab. 7.2 Emergency Operation.

In order to activate:

- Press the emergency operation/operation test switch. A beeping noise is heard which indicates that the function has been put into operation.

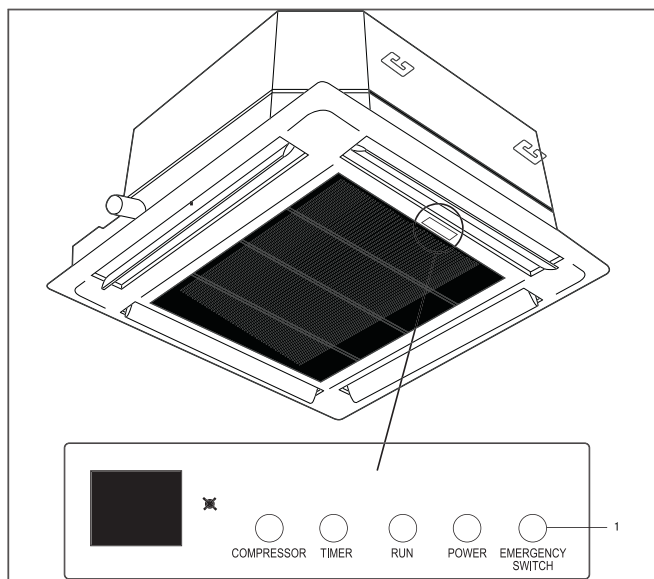

Fig 7.26 Emergency operation/operation test switch.

#### Legend

- 1 Emergency operation/operation test switch



#### Note!

When in emergency operation the dehumidifying mode is not available.

### 7.8.2 Operation Test

Only use this function to carry out operation tests when the temperature is less than 16°C.

In order to activate:

- Lift the front lid of the indoor unit.
- Keep the emergency operation/emergency test switch pressed for five seconds. A beep is heard twice which indicates the start of the function in cooling mode with the HI (high) airflow speed.
- Release the switch. After 30 minutes the function test will end automatically.

### 7.8.3 Cancellation of Emergency Operation/ Emergency Test

- Press the emergency operation/operation test switch once again or use the remote controller. The beeping stops. The unit returns to normal operating mode.

### 8 Advice for saving Energy

#### 8.1 Suitable ambient Temperature

Set the ambient temperature to an appropriate value to guarantee physical wellbeing, comfort and, in any case, to comply with the legal standard. Each degree above this value significantly increases the energetic consumption.

The temperature must also be suitable for the specific use being made of the room: the temperature of empty rooms and bedrooms does not have to be the same as the main room.

#### 8.2 Eliminating Heat or Cold Sources

In the event that there are any heat (in cooling mode) or cold (in heating mode) sources that could be eliminated please do so (e.g. a window or a door which are not properly closed). This will ensure that the unit consumes less energy.

#### 8.3 Operation in Heating Mode (Heat Pump)

Your unit, when operating in heating mode, acts as a heat pump, i.e. it takes heat from the outside (via the outdoor unit) and releases it inside (via the indoor unit). Nevertheless, a conventional heating system produces heat purely by consuming energy. Therefore, heating a room using a heat pump is far more economic than using conventional heating (radiators, heaters, boilers, etc.).

#### 8.4 Ambient Temperature when absent

During heating mode, an economic saving is made by keeping the ambient temperature at approx. 5°C lower than the normal temperature. A reduction which exceeds these 5°C does not provide any further energy savings since greater heating power is required for consecutive periods of operation in normal operating conditions. It is only worth reducing the temperature even further in the event of prolonged absences, e.g. during holidays. During winter protection against freezing must be guaranteed.

#### 8.5 Uniform Heating

Often in a house only the one room is heated. In addition to the surfaces which delimit this area, i.e. the walls, doors, windows, ceiling and floor, the adjacent rooms are also heated uncontrollably: thermal energy is unintentionally lost. It is therefore impossible to adequately heat the room and an unpleasant feeling of cold is felt (the same occurs when leaving open doors which separate heated areas and unheated areas in a limited way).

This is false economy: the heating is on and, nevertheless, the ambient temperature is not pleasant. Greater comfort and a more reasonable operating mode are gained by heating all the rooms in a house uniformly, taking into account the use being made of each room (the temperature of empty rooms and bedrooms does not have to be the same as the main room).

#### 8.6 Reduction in Consumption during Night Hours (SLEEP Function)

Your unit has a SLEEP function which allows the temperature to be modified automatically in relation to the predetermined values (in heating mode the temperature decreases slightly; in cooling mode the temperature increases slightly) during nighttime hours. Thus, apart from greater comfort being provided there is also a reduction in electric consumption. For more details regarding the SLEEP function, please consult section 7.7.1).

#### 8.7 Reduction in Consumption with programmed Operating Time (TIMER Function)

By using the TIMER function you can adjust the operation start time of your unit. Therefore, it is possible to programme the operation of your unit to make it function only when required and thus achieve economic operation.

#### 8.8 Appropriate Maintenance of the Unit

A unit in perfect condition operates efficiently, taking maximum advantage of the energy it consumes. Ensure that your unit is correctly serviced (for more details please consult section 10). In particular, make sure that the filters are kept clean and that the air inlets and outlets are not obstructed either on the indoor or outdoor unit.

### 9 Communication between the Indoor and Outdoor Units

Once the installation has been performed, the remote control must be used to identify each indoor unit with its corresponding key pair. To do so, follow this procedure:



#### Warning!

Before setting up the communication between units, the installation process must have fully completed, both the refrigerant and electrical parts, and the valve keys must be open. Otherwise the installation process will report an error and will not function.



#### Note!

Each unit must have the following setup:

- With the indoor unit connected to key set A (see installation layout), the direction should be "1"
- With the indoor unit connected to key set B (see installation layout), the direction should be "2"
- With the indoor unit connected to key set C (see installation layout), the direction should be "3"

- Power all units.
- Put the indoor unit in "Stand By" mode by pressing the "OFF" button.
- For each unit, the following steps should be followed:
  - Press the emergency button for 15 seconds as shown in figure 9.1 and you will hear 4 beeps. Release the emergency button.
  - Switch on the indoor unit with the remote control by pressing the "ON" button. When the unit switches on, it automatically goes into direction setup mode.
  - To set the direction of the indoor unit, just press the "SLEEP" button. Depending on the number of times you press it, the setup will vary:
    - By pressing once, the direction is "1" and the LED TIMER flashes once only
    - By pressing twice, the direction is "2" and the LED TIMER flashes twice
    - By pressing three times, the direction is "2" and the LED TIMER flashes three times
- Switch off the unit using the "OFF" button and the direction will be set
- This process should be repeated for each indoor unit.

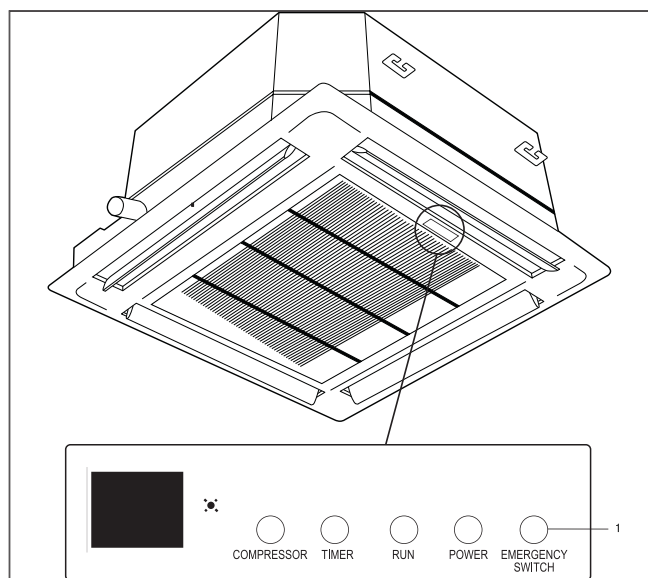

Fig. 9.1 Emergency operation/operation test switch.

#### Legend

- 1 Emergency operation/operation test switch

## 10 Troubleshooting

The table below describes a series of problems with their possible causes and solutions, see Table 10.1. If these solutions do not solve the problem contact your usual installer or call your nearest SAT Vaillant service.

SYMPTOMS	POSSIBLE CAUSES	POSSIBLE SOLUTION
The system does not work at all (the ventilation does not start)	The selector is set to "O" (stop).	Position the selector to "I" (start).
	The thermostat is set to an excessively high temperature in Cooling mode or excessively low in Heating mode.	Set the temperature correctly.
	Power supply cut.	Reconnect the power supply.
	The operating time does not coincide with the timer setting.	Wait or modify the timer settings.
	The remote controller batteries have run out.	Replace the batteries.
	The fuse has blown.	Replace the fuse. Only use the right fuses for each model. Do not use wire or other material to replace the fuse. Fires could be caused.
	Cut off from the circuit breaker or fuse.	Consult after sales service.
Insufficient cooling or heating	Very low line pressure..	Consult your electrician.
	Doors and/or windows open.	Close the doors and/or windows .
	Heat source nearby (e.g. lots of people in the room).	If possible, remove the heat source.
	The thermostat is set to an excessively high temperature in cooling mode or excessively low in heating mode.	Set the temperature properly.
	Obstacle in front of the air inlet or outlet.	Remove the obstacle to allow the air to circulate properly.
	The ambient temperature has not reached the designated level.	Wait for a few moments.
Excessive or non-existent cooling or heating	Dirty or blocked air filter.	Clean the air filter.
	The operating mode (COOL/HEAT) is not selected.	Check the operating mode selected.
	The air inlet or outlet on the indoor or outdoor unit is obstructed.	Remove the obstacle causing the blockage.
	The compressor protection has been activated three minutes.	Wait and it will operate again.
	During the operation in DRY mode the air does not flow.	At times, when in DRY mode, the airflow stops to avoid excessive cooling.
The LCD on the remote controller is blurred or with all indicators showing	When running in HEAT mode there is no airflow.	In HEAT mode the air does not flow until it is hot enough, thereby avoiding a jet of cold air. For the same reason, the air stream may not be variable.
	The remote controller batteries have run out.	Replace the batteries.
The remote controller has problems during the operation of the unit		Remove the batteries and put them back in a few minutes later.
		Press the RESET button to reset the remote controller.

**Table 10.1 Troubleshooting.**

## 11 Maintenance



**Danger!**  
**Danger of electric shock.**  
**Disconnect the unit and the thermal magnetic switch before proceeding to carry out maintenance on the unit. This will prevent injuries.**



**Danger!**  
**Danger of electric shock.**  
**Do not clean the unit with water.**



**Warning!**  
 Danger of breakdowns or malfunction.  
 Do not use petrol, solvents or polishes when cleaning the unit.

### 11.1 Cleaning the Indoor Unit

- Wipe the outer part of the unit with a dry cloth.
- Occasionally remove dust from the inlet surface.

### 11.2 Cleaning the Air Filters

The air filter eliminates the dust absorbed from the room into the indoor unit.

If the filter becomes obstructed, the air conditioner's efficiency will be reduced, the compressor could be damaged and the indoor unit's battery could freeze up. Clean the air filter regularly to prevent this from happening. In order to do so:

- Remove the air filters.
- Remove the dust or the dirt in the filters using a vacuum cleaner or cleaning them with cold water.
- Ensure that the filters are dried completely before putting them back into the unit.



**Warning!**  
 Danger of breakdowns or malfunction.  
 Do not attach perfume systems, anti-odour systems etc. in the filter or in the inside air return.  
 This can damage and soil the evaporation battery. If necessary, install these systems at the unit's outlet point and ensure they only run when the fan is on.

### 11.3 Cleaning the Outdoor Unit

- Wipe the outer part of the unit with a dry cloth.
- Occasionally remove dust from the inlet surface.
- Periodically clean the capacitor battery with a soft brush when the unit is located in a dusty environment.
- Occasionally check the base of the outdoor unit.



**Danger of injury and physical damage!**  
**A damaged or deteriorated base could make the unit fall down and cause physical or material damage.**



**Danger of injury and physical damage!**  
**Do not dismantle the outdoor unit outlet. Exposing the fan can be very dangerous.**



**Note!**  
 We advise you to contact a reliable air conditioner specialist or the Vaillant Official Technical Service to contract a preventative maintenance service. This will help to prolong the life of your equipment and improve its performance.



## 12 Storage over a prolonged Period

If you do not intend to use the unit over a period of time:

- Put the fan into operation for three or four hours in order to dry the inside of the unit.
- Stop the unit and disconnect the thermal magnetic switch.
- Clean the air filters.

Remove the batteries from the remote controller.

Before turning the unit back on:

- Position the remote controller batteries.
- Check that the air filters are not blocked.
- Check that the air outlet and inlet are not blocked.
- Check that the thermal magnetic switch is connected.



### **Danger of injury and physical damage!**

**In the event that the equipment is removed and reinstalled at a later date, ensure that the equipment is properly installed by personnel with the appropriate qualifications (see manual for installer). Otherwise water leakage, refrigerant leakage, short circuiting or even fire could be caused.**

## 13 Product Decommissioning



### **Danger of injury and physical damage!**

**When disposing of the product, ensure that the necessary precautions are taken. In order to do so follow the steps described in the installation manual in reverse order and use the necessary tools and protection resources. Ensure that the disassembly is carried out by qualified, technically competent individuals.**



### **Warning!**

**Danger of environmental contamination when disposing of the unit. To avoid this, follow the instructions described in this section.**

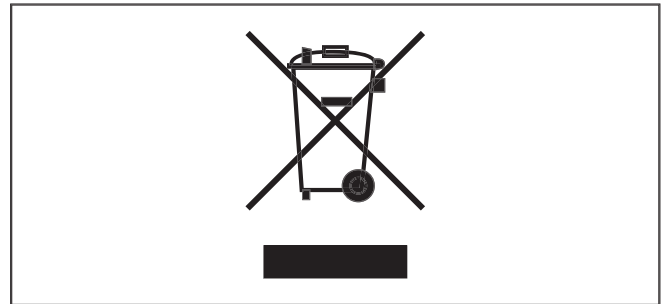

**Fig. 13.1 Recycling symbol.**

Your product is marked with the recycling symbol (see Figure 13.1), which means that the following must be taken into account during the disposal:

- Do not mix the unit with other domestic, unclassified waste.
- Dispose of the equipment in accordance with the relevant local and national standards, correctly and in an environmentally-friendly way.
- Hand in the unit to a waste management company that is authorised by the local authorities to transport it to a proper treatment plant.
- If the product is being replaced with a new product destined for the same use, hand in the old product to the distributor of the new unit for waste management as appropriate.
- Contact local authorities for more information.

