

SANGAMO

E850

SERIES

**ELECTRONIC
ROUND PATTERN TIME SWITCH**

Installation and User Instructions

Table of Contents

	Page
Introduction	3
Installation Instructions	4
Testing the Time Switch	7
Specifications	8
The Electronic Display.....	9
Normal Operating Mode	10
Setting the Digital Clock	11
Programming the Time Switch	14
Copying Programmes	19
Programme Review.....	20
Override.....	23
Holiday Mode	25
Sample Programme Chart.....	26

Introduction

General

You are now the owner of the latest design of electronic time switch incorporating years of Sangamo experience for reliability and first class workmanship.

Please read the following instructions carefully, they describe the recommended methods of installing and programming the time switch.

Guarantee

The switch is guaranteed by your supplier for three years from the date of manufacture. If it should become defective, please contact your installer or supplier for a replacement unit.

The guarantee becomes invalid if the electronic circuitry has been tampered with, or if the switch has been abused or installed in an unsuitable environment.

NOTES:

- Important: Please note that by the time this product has reached you its battery may be fully discharged.**
In this condition, when power is applied to the product, all LED segments will flash. Press 'set clock' and follow instructions on page 11.

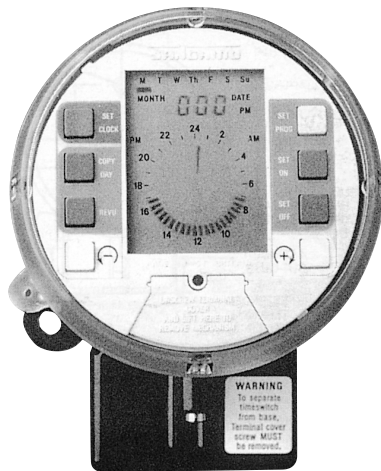

Installation Instructions

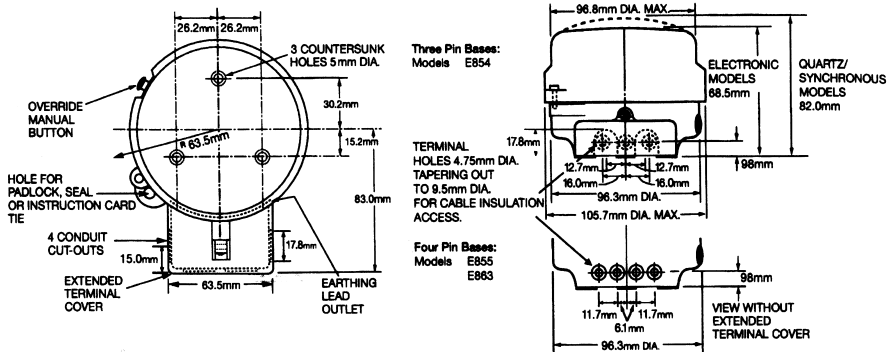

Fig. 1 Overall Dimensions and Mounting Positions

Installation Instructions

To Install

- 1) Rotate front cover anti-clockwise and lift clear.
- 2) Remove extended terminal cover A by unscrewing captive Screw B.
- 3) Lift Handle C and withdraw plug-in mechanism from switch base by pulling on Handle C.
- 4) Clear plastic from three fixing holes provided ensuring that no particles remain in base, use No. 8 woodscrews or 2BA countersunk screws for fixing.

Note: For safety reasons it is imperative that only these screw types are used and tightened so head is flush fitting within base. When fitting this time control to insulating material using wood screws ensure all metalised coverings have been removed from the area of application and fix with suitable insulated wall plugs.

Note: This product is only suitable for "Ordinary" condition i.e. this product is not protected against dripping or splashing moisture.

When mounting this time control on a metal surface ensure the metal is adequately earthed to cover 20A resistive rating in accordance with IEE regulations.

- 5) Connect switch to supply as in wiring diagram shown on page 6.
- 6) Plug mechanism into base.
- 7) Replace and secure extended terminal cover A. Ensure handle in the recessed position before tightening the terminal cover screw.
- 8) On completion of installation replace cover and rotate clockwise to fully closed position with cover lug Y in position shown in fig. 2.
- 9) **Important:** Secure instruction card to beaded tie mounted on lug Z.

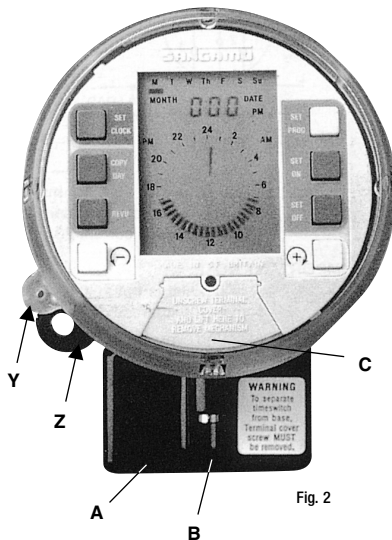
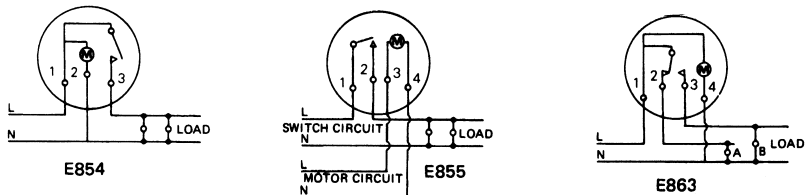

Fig. 2

Installation Instructions

Fig. 3 Electrical Connections -



NOTE: Maximum cable size 6.0mm² Strip back insulation by 8mm from the end of wire to ensure satisfactory connection with the terminals.
Maximum switch current 20A (resistive)

IMPORTANT NOTE:

- This product is not suitable for use with existing Sangamo panel mounting attachments - for clarification contact the address on back page.
- Although every care is taken to ensure the accuracy of the electrical circuit diagrams shown, Sangamo or associated companies cannot be held responsible or liable for circuit connections other than those directly associated with the E850 range of time switches.
Terminals for fixed wiring only. Provision must be made in the fixed wiring for a means of disconnection from the supply having a contact separation of at least 3mm on all poles.
Installation should be carried out by a qualified electrician in accordance with IEE regulations. Suitable earthing of the controlled equipment should be made.
- On E855 model only, where separate 230V supplies are not available for the motor and switch circuit. Fit a link between terminals 1 & 3.

Testing the Time Switch

The following tests should be carried out by the installer to check that the digital and analogue displays are functioning correctly. The test assumes that the switch is newly installed and that the digital clock has not been set.

When the E850 Electronic Switch is installed and the mains supply energised, the switch will immediately show the preset ON programme from 7 am to 5 pm. Since the digital clock is not set, the digital display will show 0:00 and the analogue hand will appear vertically upwards.

All segments of the analogue and digital display should be tested for operation as follows:

- Remove clear cover then simultaneously press the + and - buttons. All segments of the analogue and digital display should be illuminated as shown.
- Press all buttons in the following order set clk, copy day, rev, -, set prog, set on, set off, + to remove day icons. Then press the override button to initiate the walking icon pattern with each icon illuminated in turn displayed.
- The E850 will automatically revert from the test mode to normal mode 5 minutes after the last button is pressed.
- If any segments are not illuminated the switch should be returned to your supplier for replacement.

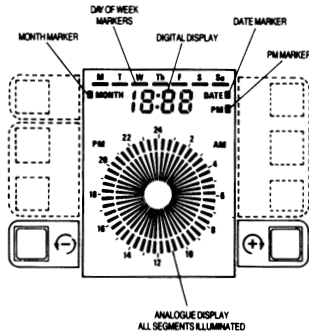

Specifications

No. of Output Channels	: 1 programme channel.
Programming Capability	: 7-day programmable.
Max. No. of Status Changes	: Up to 48 On/Off operations per day.
Override Facility	: Energy-saving, automatic, 2 Hour, 'Boost-On'. See page 23.
Digital Display	: Seven segment display to 1 minute resolution; set to the second.
Analogue Display	: 24-hour display with 30-minute programme indication and 15-minute switching capacity.
Battery Back-Up	: Automatically rechargeable battery will retain memory for typically 50 days.
Battery Recharge Time	: Battery will automatically fully recharge within typically 200 hours.
Rating of Output Switches	: Up to 20 amp (resistive) - SPST or Changeover SPDT Up to 230V - 50/60 Hz, 10,000 min switching cycles at 20A.
Holiday Mode	: Suspends program for up to 14 Days

Ambient Temperature Range:	Designed to operate over a temperature range of 0°C to 35°C continuous..
Supply Voltage	: As shown on identification label of time switch.
Max. Cable Size	: 6.0 mm
BST/GMT Changeover	: Automatic.
Accuracy	: Better than 5 minutes per annum.
Protection	: IP20
Live Parts	: Enclosed i.e. this timer is totally protected by the enclosure.
Dirt Protection	: Normal domestic dust deposits only.
Moisture Protection	: Ordinary i.e. has no special protection against moisture.
Shock Protection	: Class II, both functional and supplementary insulation.
Guarantee	: 3 years.
Mounting	: Wall mounting (see page 5).
Instructions	: Full instructions contained in handbook. Additional programming instructions reminder attached to base.
Software Class	: Class A.
Contacts	: Type 1B disconnection.

The Electronic Display

The E850 features a liquid crystal display incorporating an analogue programme display showing the switching programme in relation to a 24-hour analogue clock, and a 12-hour digital clock.

The analogue programme display shows programmed switching 'On' periods, represented by means of electronic markers as shown, and an analogue 'hand' showing the time on the 24-hour clock.

The digital display comprises a 12-hour digital clock and electronic markers to show PM, day of week, date and month.

A preset switching 'On' period from 7 am to 5 pm is automatically programmed into the time switch memory and will appear on initially connecting power to switch.

NOTES:

1. **Important: Please note that by the time this product has reached you its battery may be fully discharged. In this condition, when power is applied to the product, all LED segments will flash. Press 'set clock' and follow instructions on page 11.**
2. E850 can be set for time, programmed or reviewed whilst powered by the battery.
3. For alterations to the preset programmer see 'Programming the Time Switch' on page 14.

Normal Operating Mode

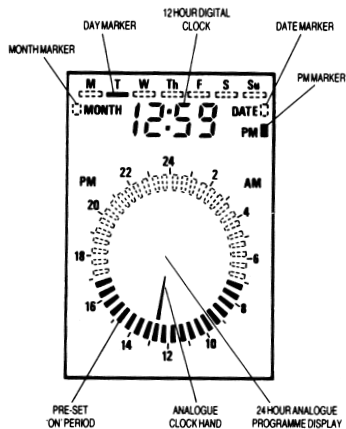

In the normal operating mode, the preset or programmed switching programme is displayed continuously on the analogue programme display. The analogue 'hand' will point to the actual time on the 24-hour analogue display and the digital clock will indicate the time and the day of the week.

Setting the Digital Clock

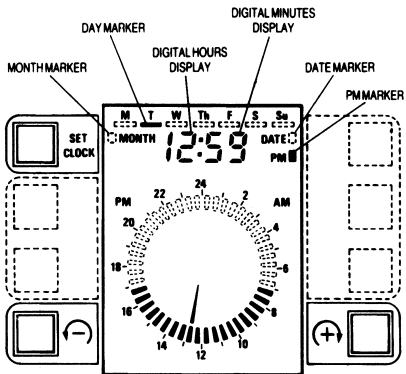

IMPORTANT NOTE: The E850 incorporates an internal, continuously charged battery which supplies power to the display and retains the preset programmes within the unit memory during a power failure (typically 50 days). **The unit will enter back-up mode with the loss of the display approx 90 secs after the mains power has been lost. The display can be restored by pressing the set on button for 5 secs.** The display will again be lost 90 secs after the last key pressed has occurred. The clock and program setting can be reviewed or amended in this mode.

Setting the Digital Clock

1. *Set Minutes*

- a) Press the **SET CLOCK** button. The minutes display will flash on and off.
- b) Press + or - button until the correct minutes setting is displayed.
- c) Press **SET CLOCK** to enter the set minutes in the unit memory. The digital hours will now be flashing on and off.

2. *Set Hours and PM Marker*

- a) Press the + or - button until the correct hours setting is displayed and the PM marker is illuminated as appropriate.
- b) Press **SET CLOCK** to enter the set hours in the unit memory. The last two digits on the digital clock will display 01 and flash on and off.

3. *Set the Year*

- a) Press + or - button until the correct year setting is displayed, ie. Y:01 = 2001.
- b) Press **SET CLOCK** button to enter the set year in the unit memory. The digital clock will display '1' and flash on and off.

Setting the Digital Clock

4. *Set the Month of Year*

- a) Press + or - button until the digital clock shows the correct month number of the year.
- b) Press SET CLOCK button to enter the set month in the unit memory. The 'Date' marker will now be flashing on and off and the last two digits of the digital clock will display 1 and flash on and off.

5. *Set the Date of Month*

- a) Press the + or - button until the digital clock shows the correct date of the month.
- b) Press SET CLOCK button to enter the set date number in the unit memory. The digital clock is now set and the switch will automatically revert to the Normal Operating mode.

NOTES

- 1. The + or - buttons can be pressed and released to increment or decrement the digital display by one digit, or held pressed to continuously advance (or retard) the display. A delay of 1 second will occur before the digital display will move continuously.
- 2. When the E850 returns to the Normal Operating mode after setting the digital clock, if it were previously in the 'Override' mode it will be set to the normal operating condition and the 'Override' cancelled.

Programming the Time Switch

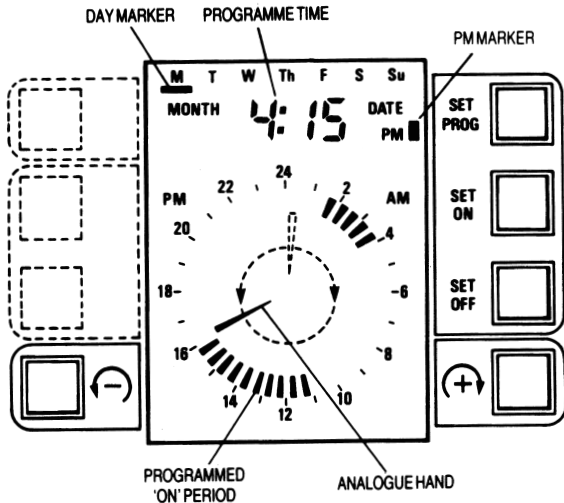

Programming the Time Switch

All E850 Electronic Time Switches are despatched from the factory programmed with a standard preset 'On' period from 7.00 am to 5.00 pm.

The programme is displayed on the analogue display for each day in accordance with the actual or selected day of the week. Discrete electronic markers on the analogue programme display represent a switch 'On' period and the absence of markers represents a switch 'Off' period.

Programming the time switch to a programme other than that set at the factory is achieved by 'painting in' or 'wiping out' 'On' markers as the analogue hand is moved around the 24-hour clock display in either direction using the + or - buttons.

NOTES:

1. It is advisable that the intended ON/OFF programme is plotted on the programme chart at the rear of this manual before programming the switch.
2. The E850 will automatically revert from the SET PROG mode to the Normal Operating mode 5 minutes after the last button is pressed. This feature protects the external circuit against the time switch being accidentally left in the SET PROG mode.

Programming the Time Switch

REMOVE THE CLEAR COVER AND PROGRAMME THE SWITCH AS FOLLOWS:-

- a) Press the SET PROG button. The analogue 'hand' will move to the vertical position at the top of the display and will be flashing on and off. The LED will also be flashing on and off indicating programming neutral mode. The day marker will sit under 'M' indicating ready to programme Monday.

NOTE: Should it be necessary to programme or amend programmes for specific days the particular day's programme can be selected by pressing the SET PROG button until the day marker is located below the required day of the week, then proceed as follows:-

- b) Press the + or - button. The analogue hand will move around the analogue clock in the appropriate direction. The + or - button can be pressed and released to increment (or decrement) the analogue hand (and digital clock) by 15 minutes, or held pressed to continuously advance (or retard) the hand and digital time. A delay of 1 second will occur before the hand (and digital clock) will move continuously. The digital clock will follow in direction and time in 15 minute steps. When the analogue hand approaches the point where it is required to 'paint in' or 'wipe out' an 'On' period, release the + or - button. The desired switching time (as displayed on the digital clock) can be approached in the 15 minute steps by momentarily pressing the + or - button.

To 'Paint In' an 'On' Period.

- c) When the digital display shows the required time to 'Paint In' an 'On' period press the **SET ON** button. The LED will remain in a constant 'on' state and the desired 'on' period can be entered by pressing + or - buttons. An 'on' marker will be 'painted in' on the display for every two depressions of either keys.

To 'Wipe Out' an 'On' Period.

- d) When the digital display shows the required time to 'Wipe out' an 'On' period, momentarily press the **SET OFF** button. The LED will remain in a constant 'off' state and the desired off period can be entered by pressing + or - buttons. An 'on' marker will be 'painted in' on the display for every two depressions of either keys.

Programming the Time Switch

NOTES:

1. The **SET ON** and **SET OFF** buttons incorporate a toggle feature. pressing either button once will set the time switch in the appropriate mode ('PAINT IN' OR 'WIPE OUT'). Pressing either button again will set the time switch in the 'neutral' mode, neither 'painting in' or 'wiping out'. This feature is useful when amending existing programmes, enabling the hand to 'skip' over existing 'On' or 'Off' periods without changing the setting. This mode is indicated by the LED flashing on and off.
 2. When the **SET ON** button is pressed followed by the + or - key, an 'On' marker will immediately appear on the analogue programme display. The 'On' marker initially represents an 'On' period of 15 minutes. Momentarily pressing the + or - button will advance (or retard) the digital clock by fifteen minutes but will not move the analogue hand. After the second depression of the + or - button, the analogue hand will move in the appropriate direction by 30 minutes, and add a second 'On' marker to the analogue display. It is therefore possible to set an 'On' or 'Off' period beginning when the digital clock minutes display shows 00, 15, 30 or 45 although the analogue display will show the 'On' period as a 30 minute segment.
- e) By use of the **SET ON**, **SET OFF**, + or - buttons the desired programme for Monday can be constructed.
 - f) Press the **SET PROG** button to set the programme for Monday into the unit memory.
 - g) The day of the week marker will then be positioned below T (Tuesday). The programming procedure is repeated as previously described and the Tuesday programme entered into the unit memory by pressing the SET PROG button.
 - h) The procedure is repeated for each day of the week until programming is completed for Sunday. The week's programme will now be contained in the unit memory, and the E850 will return to the Normal Operating mode, when **SET PROG** button is pressed once more.
- RESET** – The unit can be reset to factory default settings simply by pressing the + or - keys simultaneously until the full display occurs.
Continue pressing both keys and press set clock, revu & copy to reset the unit.

Programming the Time Switch

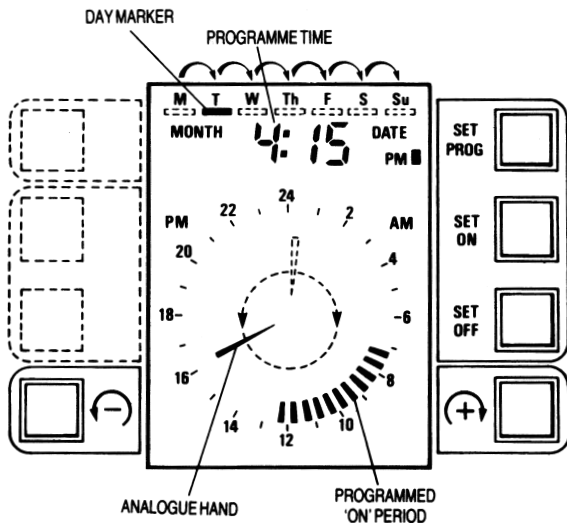

Copying Programmes

When programming is complete for one day, and the same programme is required for the next and subsequent days, the programme can be copied by pressing the **COPY DAY** button.

NOTE:

The **COPY DAY** button enters the first day's programme into the unit memory and changes the day marker to the next day. The **COPY DAY** button should be pressed instead of the **SET PROG** button as in steps (f) and (g) of the programming procedure. Pressing the **COPY DAY** button again will enter the day's programme into the unit memory and advance the day marker to the next day.

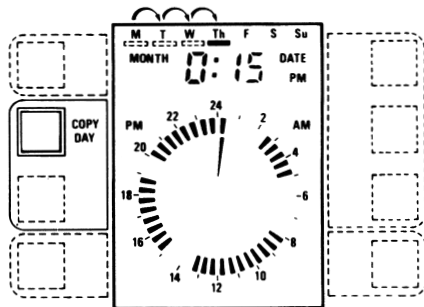

Programme Review

A review feature, incorporated within the E850 enables the user to check the programme in the unit memory for each day without affecting the normal operation of the time switch or without the risk of altering the programme.

To Review the Week's Programme

Remove the clear cover and review the programmes as follows:-

- Press the **REVU** button. The digital display and the analogue pointer will zero and the day of the week marker will be located below M (Monday).
- The analogue programme display will show the programme for Monday.
- Press the **REVU** button again and the analogue programme display will change to show Tuesday's programme and the day of the week marker will move to T (Tuesday)
- By pressing the **REVU** button after viewing each day's programme, the weeks programmes can be examined.
- Pressing the **REVU** button after viewing Sun

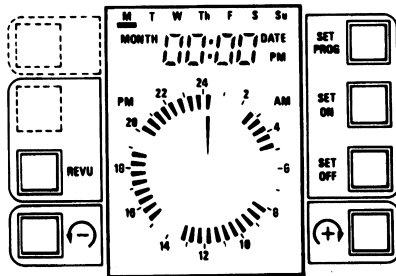

NOTE:

Should the time switch be accidentally left in the **REVU** mode, the switch will automatically return to the Normal Operating mode 5 minutes after pressing the last button.

Programme Review

The REVU features can also be used to check the exact On/Off times of the programme as follows:-

To Review Programme Settings

- a) Press the **REVU** button until the day marker is located below the day to be reviewed.
- b) Press the + or - button to rotate the analogue 'hand' round the programmed display. The digital display will continue to show the digital time until the 'hand' crosses an 'On' or 'Off' period. The digital display and LED will immediately change and display the time of the change and the on/off state. The display will revert to 00:00 on crossing 24hr. If a 'painted on' period commenced at 15 mins before the hour a 30 min segment is displayed. By rotating the 'hand' around the analogue display, the time of each change of state can be noted from the digital display.
- c) The time switch is returned to the Normal Operating mode by pressing the **REVU** button repeatedly until the day of the week marker is located below Su (Sunday). Pressing the **REVU** button again will return the switch to the Normal Operating mode.

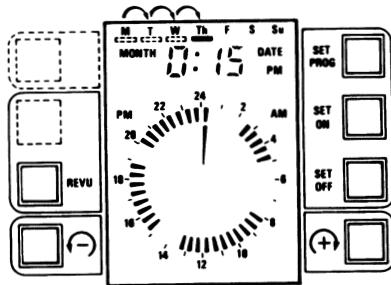

Programme Review

Amending a Programme While Reviewing.

Any programme under review may be amended by pressing the **SET PROG** button. This will change the switch to the programming mode, and the programme may be amended using the **SET ON** and **SET OFF** buttons to 'Paint in' or 'Wipe out' 'On' periods within the programme. The switch may be returned to the Review mode by pressing the **REVV** button or to the Normal Operating mode by repeatedly pressing the **SET PROG** button to Su (Sunday). One further press returns the switch to the Normal Operating mode.

Reviewing a Programme While Programming.

During programming, it may be necessary to check the time setting of a change of state. This is achieved by pressing the **REVV** button and using the + or - buttons to move the analogue 'hand' to the period to be checked. The digital clock will change to show the time of each change of state as previously described. The time switch is returned to the Review Operating mode by repeatedly pressing the **REVV** button to Su (Sunday). One further press returns the switch to the Normal Operating mode.

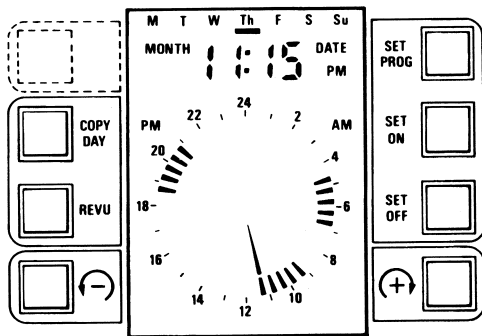

Override

NOTE:

If the SET CLOCK or SET PROG buttons are operated whilst circuit is in the OVERRIDE condition, the override for that circuit will be cancelled when the time switch returns to the normal operating mode.

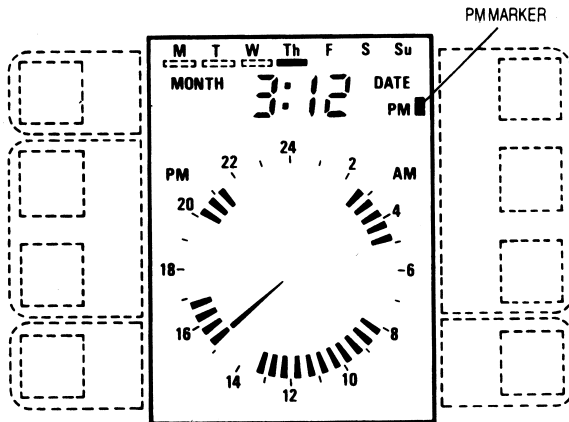

Override

An override button provides an emergency facility to set the switch from an 'On' state to an 'Off' state or vice-versa and is accessible with the clear cover fitted.

NOTE:

If the output circuit is currently 'On' pressing the OVERRIDE button will immediately switch the circuit 'Off'. The remainder of the programmed 'On' period will be temporarily deleted from the analogue programme display and the circuit will remain 'Off' until the analogue 'hand' reaches the next 'On' period. At that point, the Override mode is cancelled, the circuit will automatically return to the Normal Operating mode, and the deleted part of the 'On' period will return to the analogue programme display.

If the output circuit is currently 'Off', pressing the OVERRIDE button will immediately switch the circuit 'On' for a preset period of two hours. The analogue programme display will show the override 'On' period by means of four programme 'On' markers. The circuit will remain 'On' until the end of the two hour period and then return automatically to the Normal Operating mode. The override programme markers will then be deleted from the display.

NOTE:

If the next programmed 'On' period for the circuit is less than two hours from the current time, pressing the **OVERRIDE** button will immediately switch the circuit from 'Off' to 'On'. The number of programmed 'On' markers required to ensure that the switch is 'On' until the next programmed 'On' period is reached are inserted in the programme display. Whenever the programmed 'On' period is reached the **OVERRIDE** condition is cancelled, the circuit will automatically return to the Normal Operating mode and the **OVERRIDE** markers are deleted from the display.

The overridden circuit may be manually returned to the Normal Operating mode at any time during the Override period by pressing the **OVERRIDE** button again.

Holiday Mode/ Permanent off

- Press and hold the set off button for approx 5 secs until H:1 is displayed.
- Press + key to increment holiday value or reach 'HOL'.
- 'HOL' displayed means switch is in permanent off mode.
- Press - key to decrement holiday mode.
- Press set prog button to enter holiday mode.
- The holiday mode/ permanent off can be terminated manually by pressing the **SET ON** button.

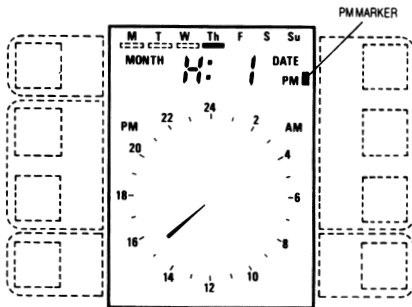

Should the timeswitch be accidentally left in the holiday mode, the switch will automatically enter the holiday period displayed and go into holiday mode after 5 minutes.

Sample Programme Charts

Example No.	Monday	Tuesday	Wednesday	Thursday	Friday	Saturday	Sunday
1.	On - 7.00 am Off - 12.15 pm On - 1.00 pm Off - 4.15 pm	Copy Monday	Copy Monday	Copy Monday	On - 7.00 am Off - 12.15 pm On - 1.00 pm Off - 3.30 pm	On - 7.30 am Off - 12 noon	Off - all day
2.	On - 5.00 am Off - 7.00 am On - 9.00 am Off - 11.00 pm	Copy Monday	Copy Monday	Copy Monday	On - 5.00 am Off - 7.00 pm On - 9.00 pm	Off - 1.00 am On - 6.00 am Off - 7.00 am On - 11.00 am	Off - 3.00 am
3.	On - 9.00 am Off - 12 noon On - 1.30 pm Off - 7.00 pm	Copy Monday	Copy Monday	Copy Monday	On - 8.00 am Off - 12 noon On - 1.30 pm Off - 4.30 pm	On - 6.30 am Off - 12 noon	Off - all day
4.	On - 5.00 am Off - 7.00 am On - 9.00 am Off - 11.00 pm	Copy Monday	Copy Monday	Copy Monday	On - 7.00 am Off - 12.30 pm On - 11.00 pm	Off - 3.30 pm On - 8.00 am Off - 12.30 pm On - 9.00 pm	Off - 1.00 am

User Programme Charts

Prog No.	Monday	Tuesday	Wednesday	Thursday	Friday	Saturday	Sunday
1.							
2.							
3.							
4.							

The E850 range contains a rechargeable battery for memory and data retention, it should not be disposed of with normal domestic waste. This battery should be removed by a competent engineer and disposed of in accordance with local regulations, alternatively the batteries should be returned to our Port Glasgow address for safe disposal. Please mark the return packaging for the attention of the E.O.L. Department.

As part of Sangamo's commitment to preserving the environment, we recommend that, when the product and packaging have reached the end of their useful life, they should be disposed of in an environmentally friendly manner, in accordance with local regulations. The company operates an 'end of life' product return policy, whereby a product that has reached the end of its life or is no longer required, can be returned to the address below for safe recycling, recovery and/or disposal. Please mark your return packaging for the attention of the E.O.L. Department.

The product that you have just purchased may contain some components recovered from products within the guarantee period. This has been done in the spirit of the WEEE directive which requires us to recycle, reuse or recover component parts of our products. All recovered components have been identified as 'non-critical' and have been inspected to our normal high standards.

CUSTOMER CARE POLICY

As part of Sangamo's continuous improvement programme, the Company operates a Customer Care Policy. This means that we welcome your comments and complaints, as it can only help us to improve our services to you, our customer.

Due to our policy of continuous product improvement and development, the specifications in this guide may be subject to change without prior notice.

Sangamo Ltd.

Industrial Estate, Port Glasgow
Renfrewshire, PA14 5XG

Tel: (01475) 745131 Fax: (01475) 744567

Website – www.sangamo.co.uk

