

# Installation Instructions for Oil Tank Heater Stand, Option ST1

Applies to: Oil-Fired Heater Models OH 95, 140, 190; RA 110, 140, 150, 235, 250; RV 225, 325 and a Model OT-250 Oil Tank

## Description/ Application

### IMPORTANT

The Option ST1 heater stand may **only** be used with a Reznor® Model OT-250 workbench oil tank and one of the Reznor heaters listed below.

Model.....Sizes

OH.....95, 140, 190  
 RA.....110, 140, 150, 235, 250  
 RV .....225, 325

**DO NOT** use this heater stand with any other models or sizes of heaters.

Option ST1 heater stand is designed to be field-assembled to a Model OT-250 workbench oil tank for the purpose of supporting a Reznor® oil-fired unit heater. Adding the optional stand to the tank creates a unified tank/heater structure. Suspension of the heater is not required when it is installed on the heater stand.

Select a location that will allow for required heater clearances as shown on the rating plate and in the heater installation manual.

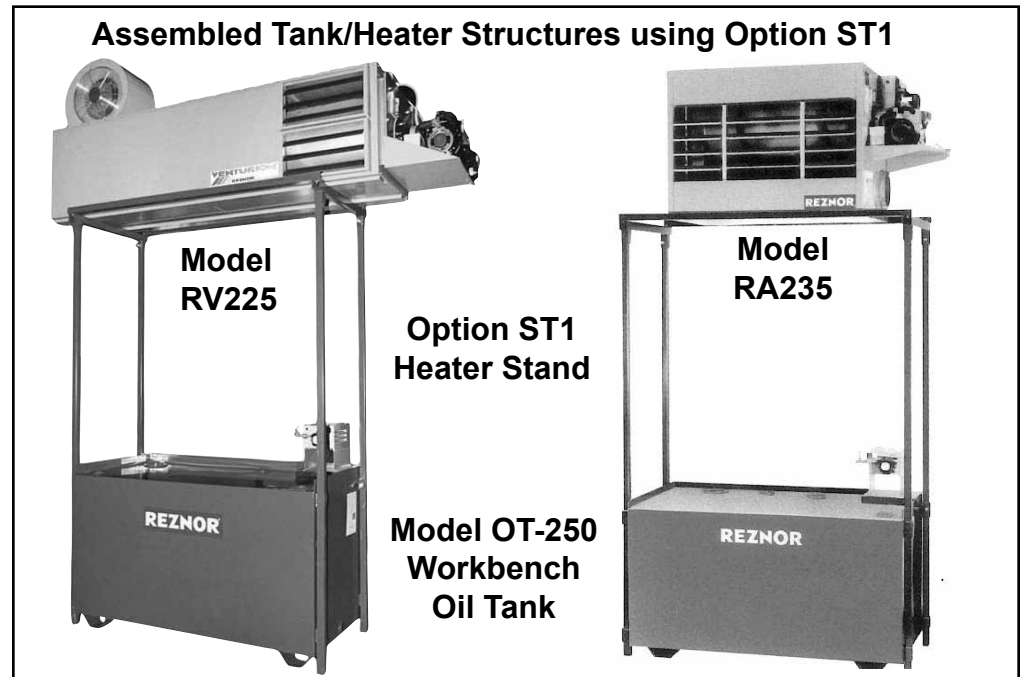

## Components

Before beginning installation, verify components against the list below.

Check for damage. If damage is found, file a claim with the transporting agency.

Option STI Package P/N			202829
Components:		Qty	P/N
Structural Parts and Label for all installations	Corner Post, 1-1/2" square tubing, approximately 8 feet long	4	202826
	Tube Bracket Assembly, 2" square tubing	2	202828
	Warning Label	2	121734
	Front and Rear Support Angle 1-1/2" x 1-1/2" x 64" long	2	202827
Corner Hardware for all installations	Hex Head Cap Screw, 1/2-13 x 3/4"	4	121593
	Flat Washer, 1/2"	4	121595
	Lock Washer, 1/2"	4	111306
Setscrew Hardware for all installations	Hex Head Cap Screw, 1/2-13 x 1-1/2"	8	121596
	Jam Nut, 1/2 -13	8	45550
Angle Stops and Hardware (See application listed.)	Angle Stop, 1-1/2"x1-1/2"x1-1/4" lg w/ 3/8 & 7/32 holes - for OH & RA	4	202825
	Hex Head Cap Screw, 5/16-18 x 3/4" - for OH and RA	4	16247
	Hex Head Nut, 5/16-16 - for OH and RA	4	1035
	Flat Washer, 5/16" - for OH and RA	4	27761
	Lock Washer, 5/16" - for OH and RA	4	1333
	Angle Stop, 1-1/2"x1-1/2"x1-1/4" lg w/ (2) 9/32 holes - for RV	4	202830
	1/4-20 3/4" long F-point Screw - (8) for RV and (4) for RA 150, 250	8	114687

# Stand Dimensions

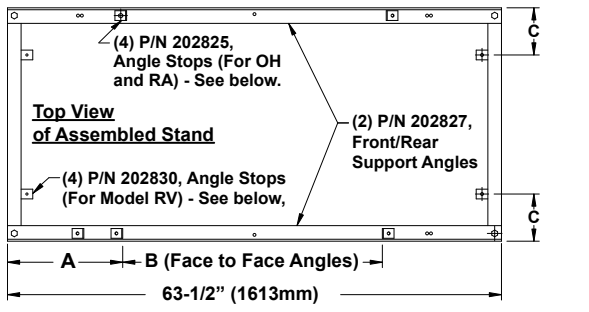

Model/Size	A		B		C	
	inches	mm	inches	mm	inches	mm
OH 95, 140, 190; RA 110, 140	14-13/16	376	33-3/8	848	--	--
RA 235	9-13/16	249	43-3/8	1102		
RV 225, 325	--	--	--	--	6-1/16	154
RA 150	14-7/8	378	33-1/4	845	--	--
RA 250	9-7/8	251	43-1/4	1099	--	--

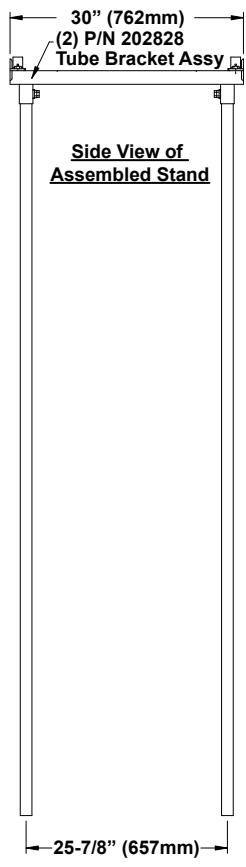
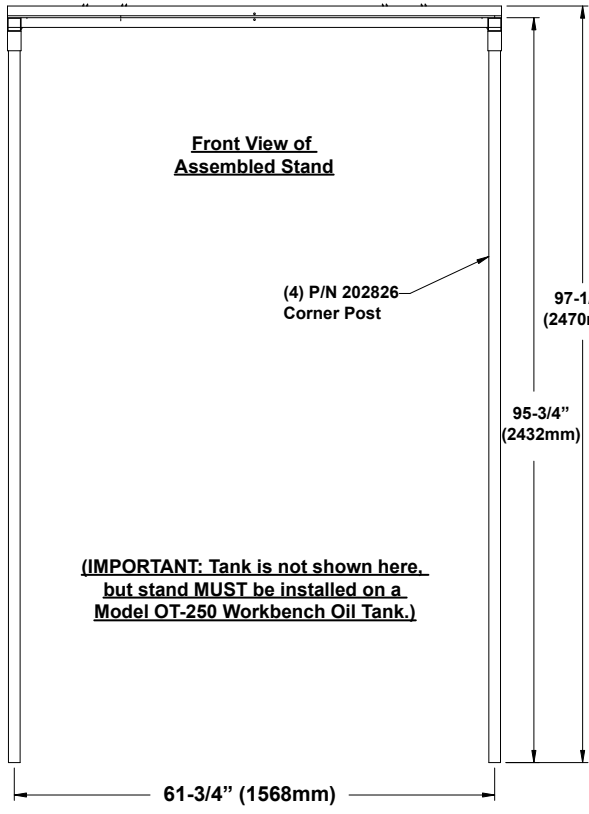

**Identify Angle Stops to use by their Hole Sizes**

Angle Stop, P/N 202825, for Models RA and OH

(1) 3/8 dia hole  
(1) 7/32 dia hole

---

Angle Stop, P/N 202830, for Model RV

(2) 9/32 dia holes

## Instructions

**WARNING: Do not attempt to adapt this stand to fit any other oil tank; use only with Reznor® Model OT-250 above ground oil supply tank. Use stand only with Reznor® oil-fired unit heater models and sizes listed on page 1.**

- 1. Model OT-250 Oil Tank** – If the tank has not been installed, follow the handling instructions supplied with the tank. Contact the local fire marshal to assure compliance with local regulations and codes. The oil supply tank must be installed in accordance with national and local codes.

Proper tank and stand installation is the responsibility of the installer. Select the tank location with consideration for tank venting requirements, heater clearances (refer to the heater installation manual), and heater venting. Tank must be level and stable.
- 2. Install Heater Stand Corner Posts** – Slide the four corner posts (8-ft lengths of square tubing) down through the upper and lower sleeves that are welded to the ends of the tank.



### 3. Prepare and Install the Tube Bracket Assemblies

Being sure they are in the correct orientation, attach a warning label to each tube bracket assembly. At the sides of the tank, connect the posts by sliding a tube bracket down over the top of each post.

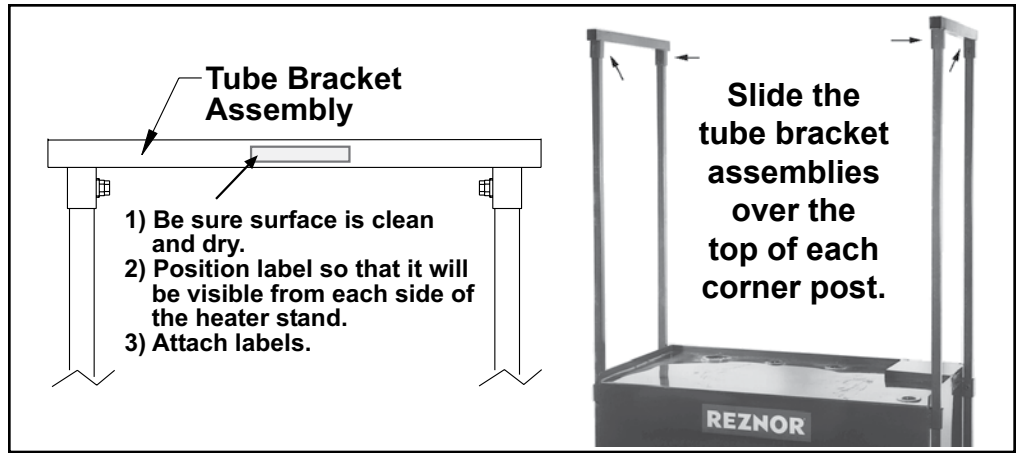

### 4. Install Front and Rear Support Angles, Corner Setscrews, and Angle Stops

Select and follow the illustrated instructions for the heater being installed.

Instructions for assembling and installing the eight setscrews used in Steps 4 & 5:

**Parts:** (8) P/N 121596, 1-1/2" lg cap screws and (8) P/N 45550, jam nuts

**Assemble:** Thread a nut down the length of each screw.

**Install:** 1) Thread the assembled screw and nut into the threaded hole.

2) Tighten the screw to 190 in-lbs.

3) Finger tighten the jam nut against the tube or sleeve.

4) Using a wrench, tighten the jam nut 1/8 to 1/4 turn.

#### Corner and Angle Stop Assembly for Models RA 110, 140, 235 and Models OH 95, 140, 190

**a)** Position rails as illustrated, attaching ends with 3/4" long screws and washers.

**b)** At each corner, install the assembled 1-1/2" cap screw and jam nut. Follow instructions above.

**c)** Attach angle stops. See illustration on page 2 for selection and the table for spacing (A and B).

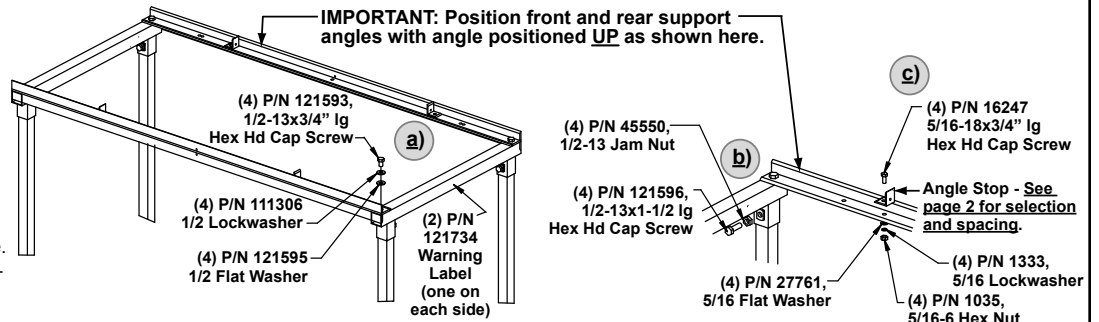

#### Corner and Angle Stop Assembly for Models RA 150 and 250

**a)** Position rails as illustrated, attaching ends with 3/4" long screws and washers.

**b)** At each corner, install the assembled 1-1/2" cap screw and jam nut. Follow instructions above.

**c)** Attach angle stops. See illustration on page 2 for selection and the table for spacing (A and B).

**d)** After the heater is centered front to back on the stand, attach each angle to the heater side using a 3/4" long F-pointed screw.

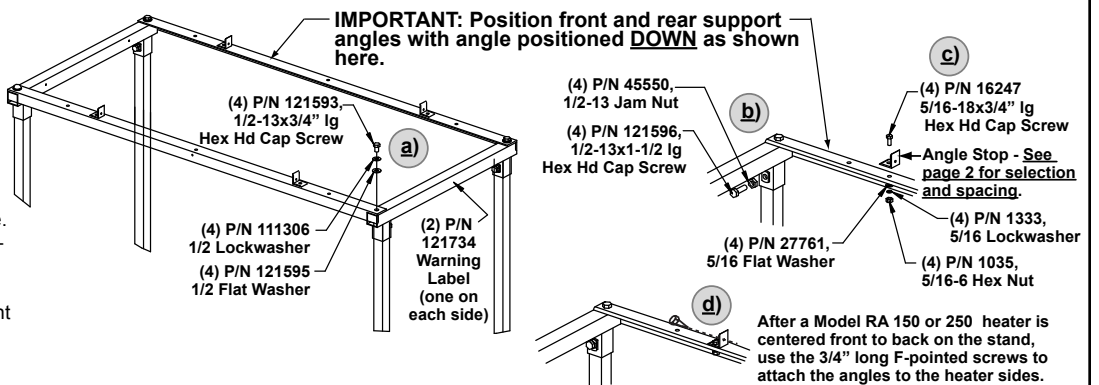

#### Corner and Angle Stop Assembly for Models RV 225 and 325

**a)** Position rails as illustrated, attaching ends with 3/4" long screws and washers.

**b)** At each corner, install the assembled setscrew. Follow instructions above.

**c)** Attach angle stops. See illustration on page 2 for selection and table for spacing (C).

**d)** After the heater is placed on the stand, attach each angle to the heater bottom using a 3/4" long F-pointed screw.

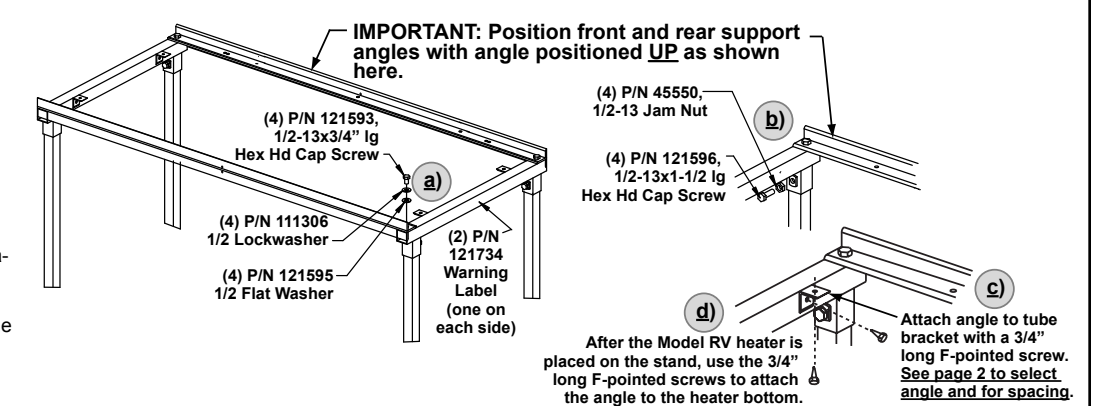

## Instructions (cont'd)

### 5. Install Setscrews in Upper Tank Sleeves

Following the instructions in Step 4, install the remaining four assembled setscrews at the upper tank sleeves.

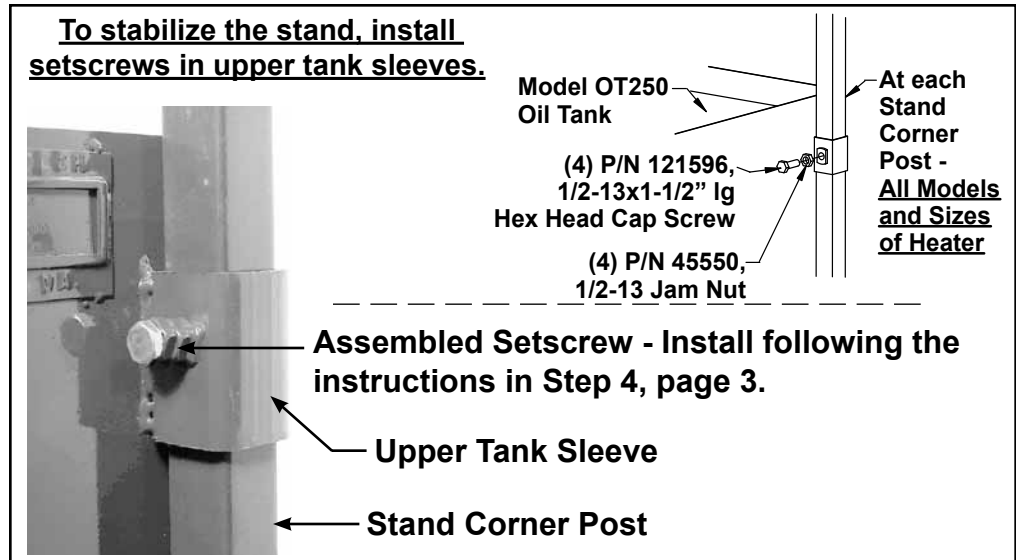

6. Assembly of the heater stand is complete. Before setting the heater on the stand, verify the following:

- Are all bolted connections and setscrews tightened sufficiently?
- Is the tank/stand assembly level and stable?
- Will there be adequate clearances to combustibles? (Refer to the heater rating plate or installation manual.)
- Will there be any structural interferences with the heater in place?

7. After the heater is set on the stand and before proceeding with the installation, attach angle stops to the heater cabinet.

**If installing a Model RV**, attach the angle stops to the bottom of the heater. (See the illustration in Step 4, page 3, that applies to Model RV.)

**If installing a Model RA 150 or 250**, center the heater front to back on the stand and attach the angle stops to the sides of the heater. (See the illustration in Step 4, page 3, that applies to Model RA 150 and 250.)

**If installing a Model OH 95, 140, 190 or RA 110, 140, 235**, the unit fits between the rails and does not require that the stops be attached to the heater. However, the screws are included and may be used to attach the angle stops to the sides of the heater

---

**WARNING: For your safety, verify that all applicable procedures in Steps 1-7 have been completed before continuing with the heater installation.**

---

---

**DANGER: Do not use this heater stand structure to support any weight in addition to one heater (*USE ONLY* with one Reznor® Model RA110, RA140, RA150, RA235, RA250, RV225, RV325, OH95, OH140 or OH190). Maximum weight limit is 500 lbs. **DO NOT** use heater stand with models or sizes of heaters not listed.**

---

**DANGER: Do not sit on, climb, or hang from any part of the heater stand. Do not lean a ladder against the heater stand structure or the heater.**

---

**Used Oil Models RA & RV:** [www.ReznorHeaters.com](http://www.ReznorHeaters.com); 855-584-3172

**No. 2 Oil Model OH:** [www.RezSpec.com](http://www.RezSpec.com); 800-695-1901