

42

Installation, use and maintenance instructions



## Forced draught gas burner

One stage operation

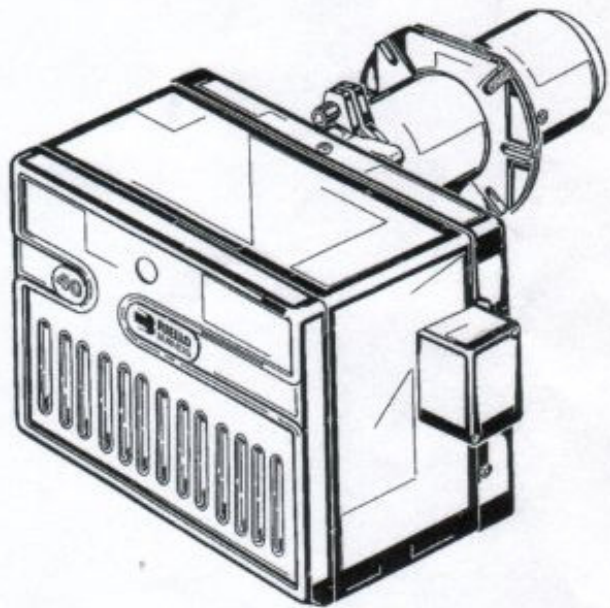

# RIELLO 40

CODE	MODEL	TYPE
3755252	GS5P	552T51

## BURNER USE WITH APPLICATIONS ACCORDING TO PrEN 1020.

### TECHNICAL FEATURES

Thermal output	18 – 58 kW – 15,500 – 50,000 kcal/h	
Gas (Family 2)	Net heat value	8 – 12 kWh/m <sup>3</sup> – 7,000 – 10,340 kcal/m <sup>3</sup>
	Pressure	min. 20 mbar – max. 35 mbar
Electrical supply	single phase, 230V ± 10% ~ 50Hz	
Motor	230V / 0.65A	
Capacitor	2 µF	
Ignition transformer	primary 0.2A / 230V – secondary 8 kV	
Absorbed electrical power	0.11 kW	

**For gas family 3 (LPG) ask for separate kit.**

- ◆ The burner meets protection level of IP 40, EN 60529.
- ◆ According to directives: EMC 89/336/EEC, Low Voltage 73/23/EEC and Machines 98/37/EEC.
- ◆ **FOR GAS TRAIN SEE THE APPLIANCE TECHNICAL INSTRUCTIONS.**

Fig. 1

- 1 – Air-dampers
- 2 – Screws for fixing the air-damper
- 3 – 6 pole gas-train plug
- 4 – 7 pole electrical controls plug and socket
- 5 – Grommet
- 6 – Screw for fixing the cover
- 7 – Lock-out lamp and reset button

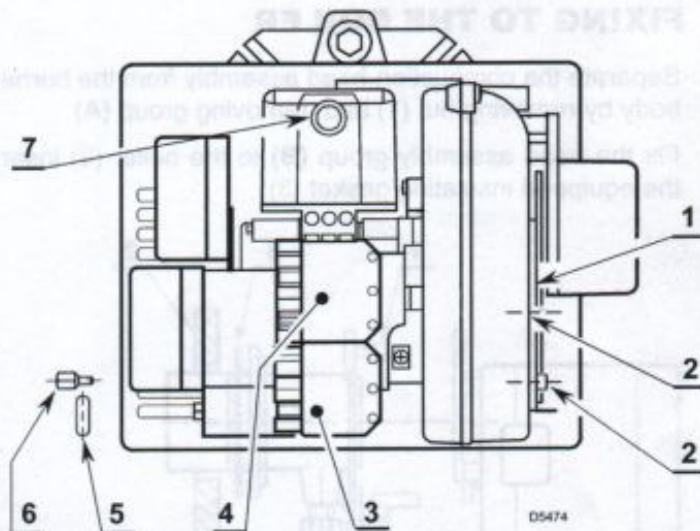

### NOTE

The grommet (5) and the screw for fixing the cover (6) supplied with the burner, must be fitted to the same side of the gas train.

## DIMENSIONS

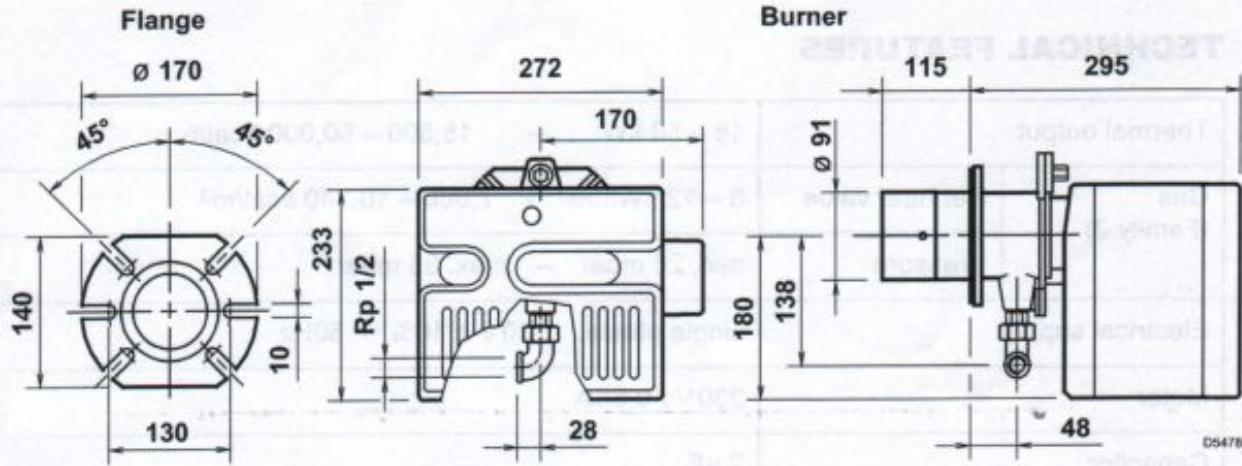

## EQUIPMENT

Quantity	Description
1	7 pin plug
1	6 pin plug
4	Screws with nuts
1	Insulating gasket
1	Screw for fixing the cover
1	Grommet
1	Hinge

## FIXING TO THE BOILER

Separate the combustion-head assembly from the burner body by removing nut (1) and removing group (A).

Fix the head assembly group (B) to the boiler (2) insert the equipped insulating gasket (3).

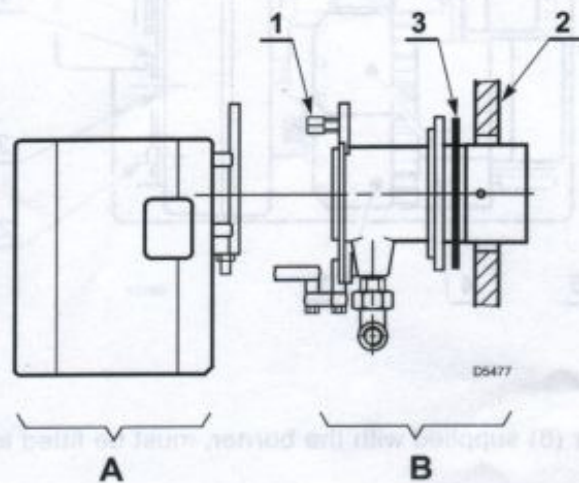

## HINGE ASSEMBLY

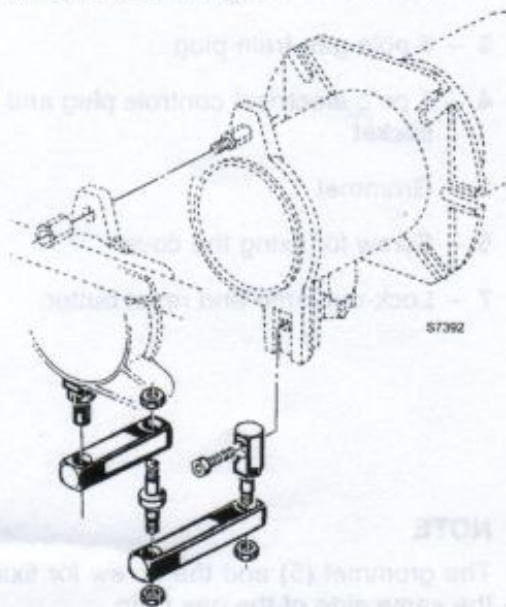

## WORKING RANGE

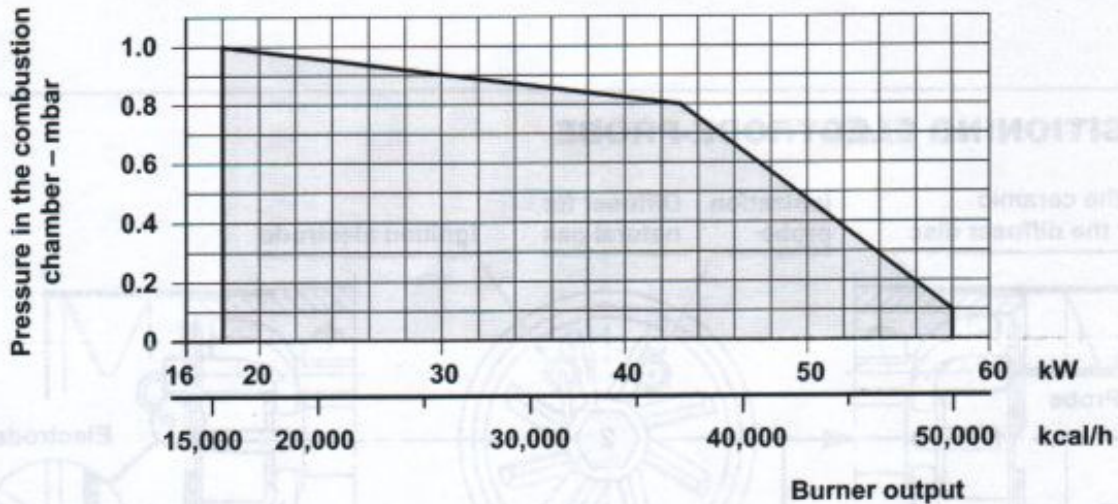

## TEST BOILER

The working field has been defined according to EN 676 standards.

## CORRELATION BETWEEN GAS PRESSURE AND BURNER OUTPUT

To obtain the maximum output, a gas head pressure of 4.6 mbar is measured with the combustion chamber at 0 mbar using gas G20 with a net heat value of 10 kWh/m<sup>3</sup> (8,570 kcal/m<sup>3</sup>).

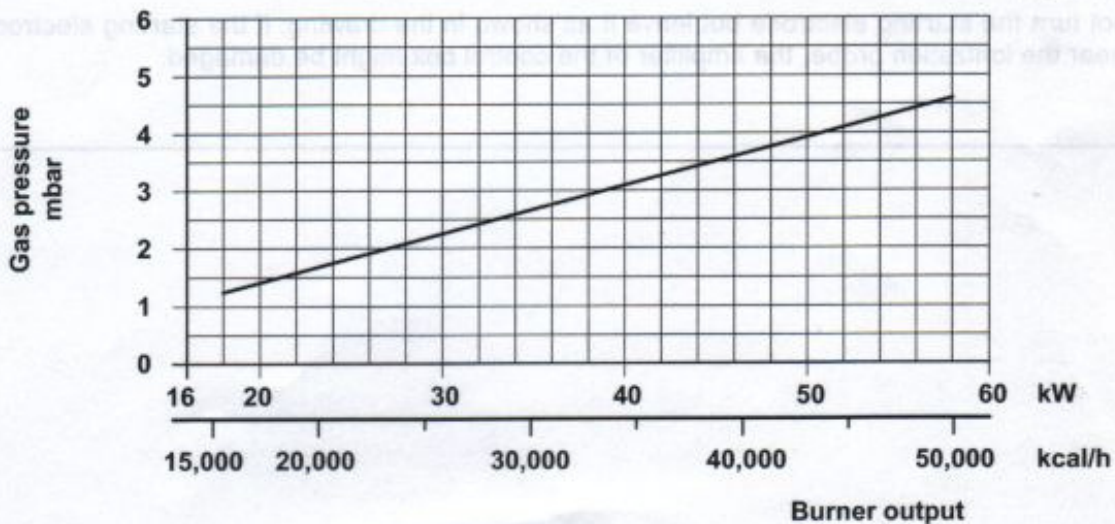

## GAS TRAIN DETAIL

For gas train information please see the appliance technical instruction.

## POSITIONING ELECTRODE-PROBE

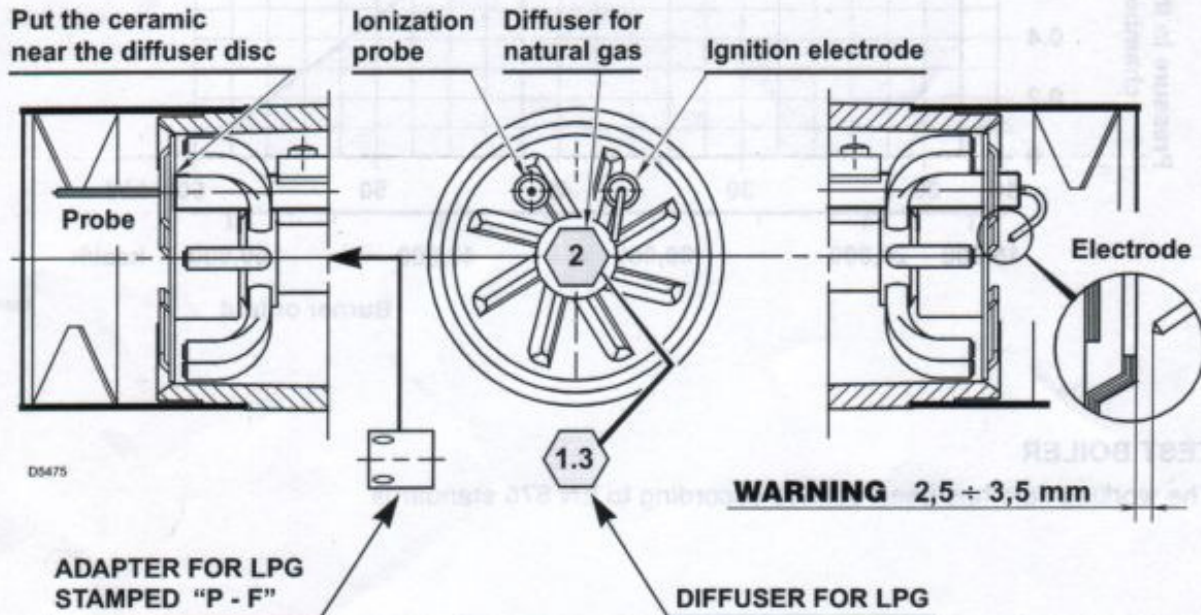

### IMPORTANT

Do not turn the starting electrode but leave it as shown in the drawing; if the starting electrode is put near the ionization probe, the amplifier of the control box might be damaged.

# BURNER ELECTRICAL WIRING

(carried out in the factory)

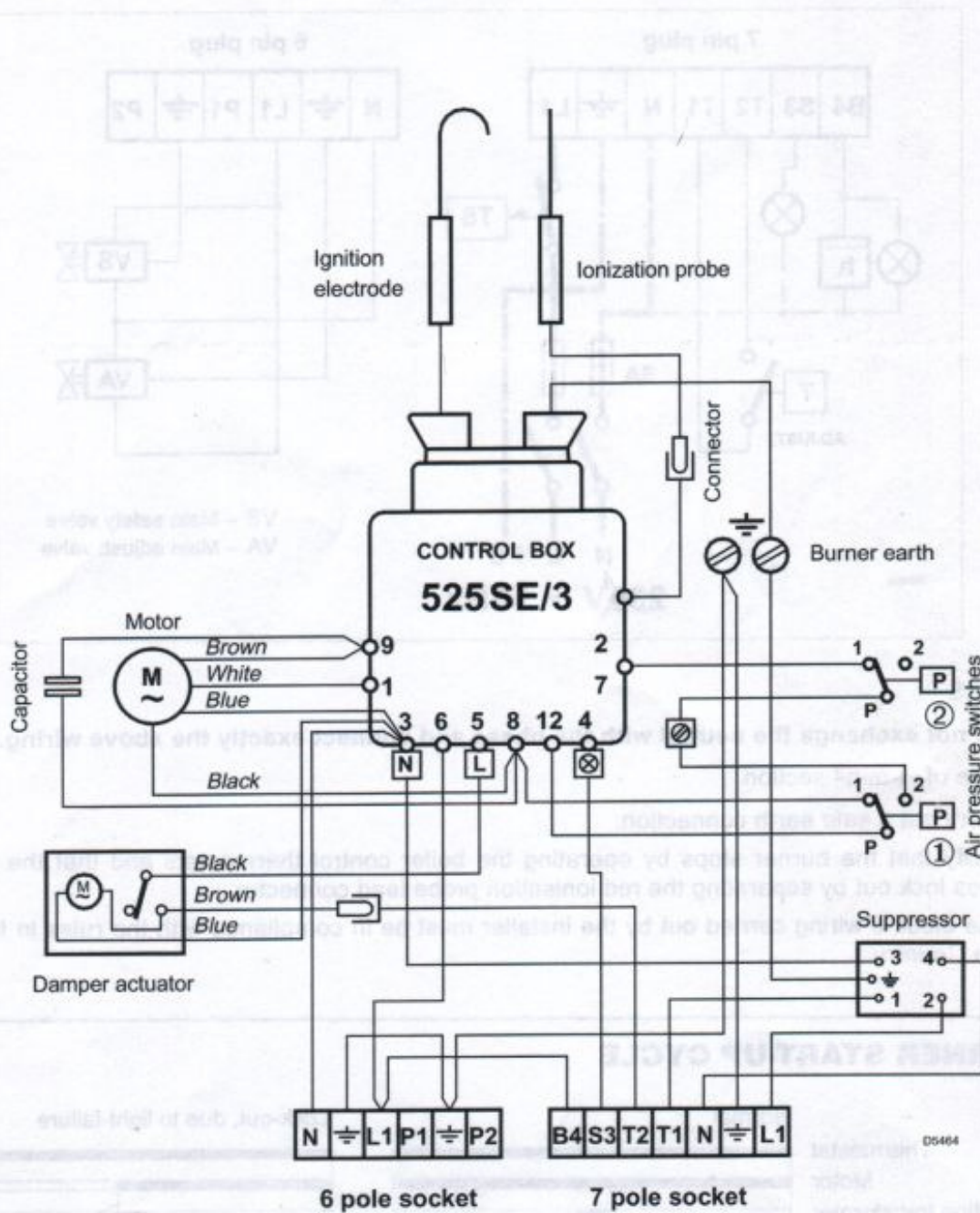

- ① Air pressure switch
- ② Over pressure switch

## ELECTRICAL WIRING

(to be carried-out by the installer)

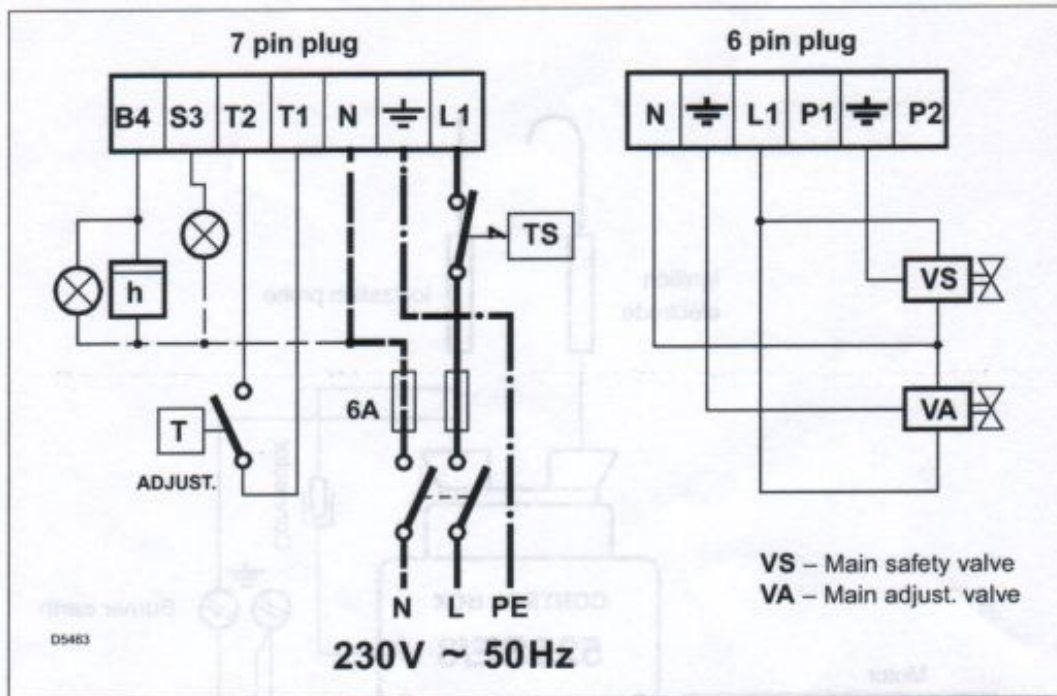

### NOTES

- Do not exchange the neutral with the phase and connect exactly the above wiring.
- Wire of 1 mm<sup>2</sup> section.
- Carry out a safe earth connection.
- Verify that the burner stops by operating the boiler control thermostats and that the burner goes lock out by separating the red ionisation probe lead connector.
- The electric wiring carried out by the installer must be in compliance with the rules in force in the Country.

### BURNER START-UP CYCLE

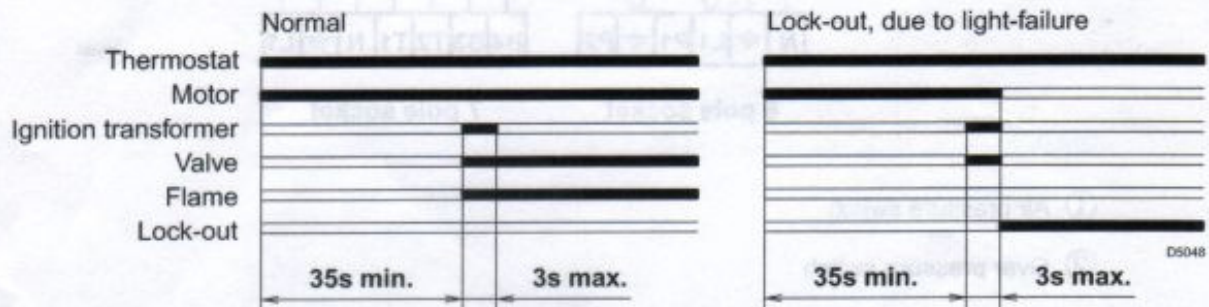

When flame-failure occurs during working, shut down takes place within one second; and the cycle starts again; a lock-out follows if the flame do not start.

## AIR DAMPER ADJUSTMENT

The air damper (1) is operated by the motor (2) and assures that the air damper is fully open before the burner start cycle begins .

The regulation of the air plate is made by adjusting the disc (3) after releasing the screws (4).

When optimum setting is reached, **tighten the screws (4)**, the air damper leaves the factory set at position 3.

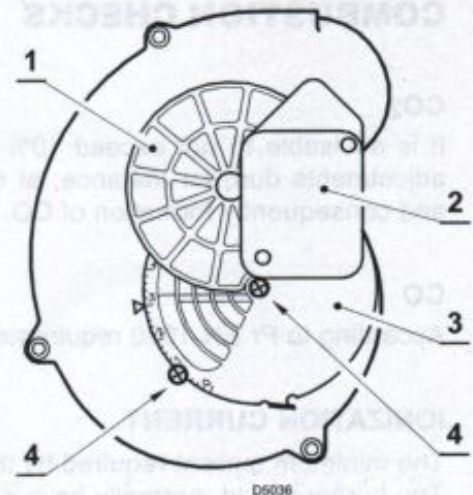

## COMBUSTION-HEAD ADJUSTMENT

Loose the screw (A), move the elbow (B) so that the rear plan of the coupling (C) coincides with the set point.

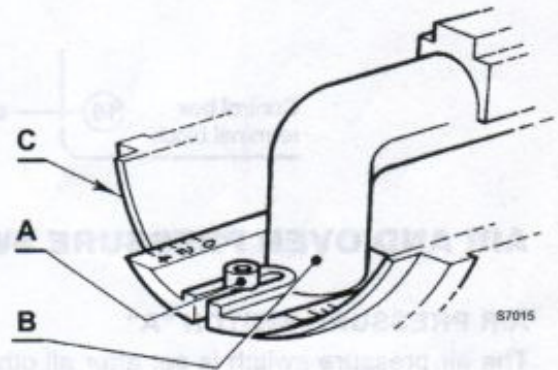

### Example:

The burner is installed on a 40 kW boiler with an efficiency of 90%, the burner input is about 44 kW using the diagram below, the combustion set point is 3.

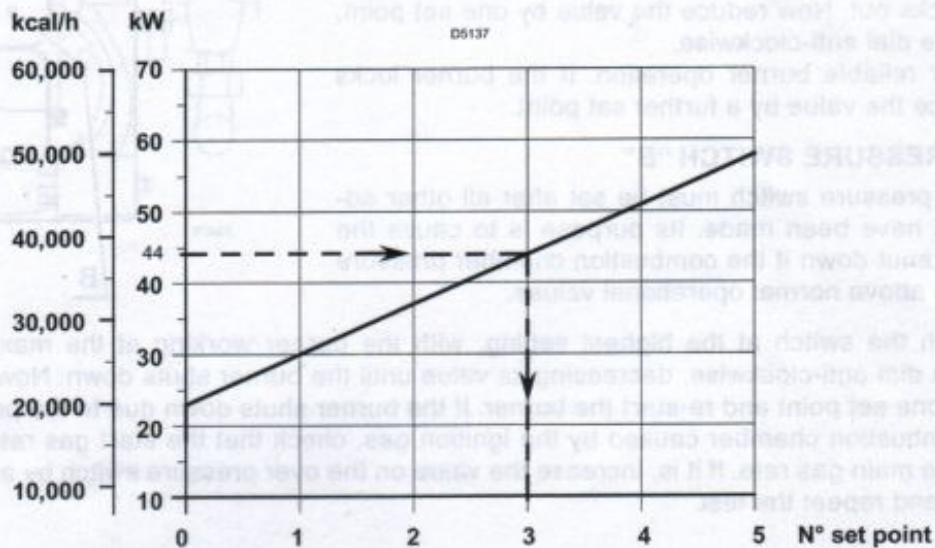

The diagram is to be used only for initial settings, to improve air pressure switch operation or improve combustion, it may be necessary to reduce this setting (*set point toward position 0*).



## COMBUSTION CHECKS

### CO<sub>2</sub>

It is advisable to not exceed 10% of CO<sub>2</sub>, in order to avoid the risk that small changes of the adjustments due, for instance, at draught variation, may cause combustion with insufficient air and consequently formation of CO.

### CO

According to Pr EN 1020 requirements.

### IONIZATION CURRENT

The minimum current required by the control box is 3  $\mu$ A.

The burner would normally have a higher current value than this, but if a check is required, open the connector fitted in the red probe lead and insert a microammeter as shown.

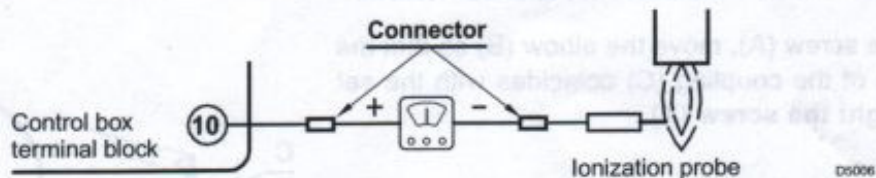

## AIR AND OVER PRESSURE SWITCH

### AIR PRESSURE SWITCH "A"

The air pressure switch is set after all other adjustments have been made. Begin with the switch at the lowest setting. With the burner working at the minimum output, adjust the dial clockwise, increasing its value until the burner locks out. Now reduce the value by one set point, turning the dial anti-clockwise.

Check for reliable burner operation. If the burner locks out, reduce the value by a further set point.

### OVER PRESSURE SWITCH "B"

The over pressure switch must be set after all other adjustments have been made. Its purpose is to cause the burner to shut down if the combustion chamber pressure increases above normal operational values.

Begin with the switch at the highest setting, with the burner working at the maximum output, adjust the dial anti-clockwise, decreasing its value until the burner shuts down. Now increase the value by one set point and re-start the burner. If the burner shuts down due to the pressure surge in the combustion chamber caused by the ignition gas, check that the start gas rate is less than 25% of the main gas rate. If it is, increase the value on the over pressure switch by a further half a set point and repeat the test.

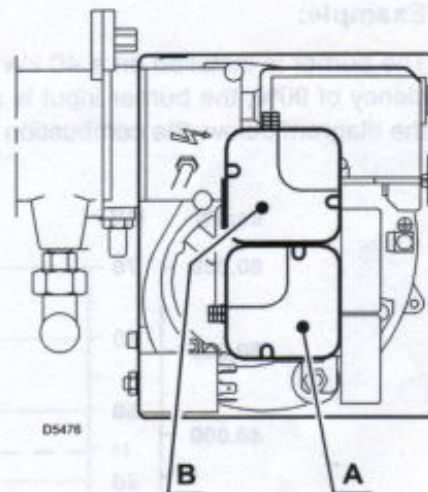

### Note:

To comply with the Appliance Standard Pr EN 1020, the CO value must not exceed 0.1% under normal operational conditions.

## BURNER STARTING DIFFICULTIES AND THEIR CAUSES

DIFFICULTIES	CAUSES
The burner goes through the pre-purge period normally, the flame ignites, but the burner goes to lock-out within 3 seconds after the ignition.	The ionization probe is earthed or not in contact with the flame, or its wiring to the control box is broken, or there is a fault on its insulation to earth.
	The connection of the phase and neutral leads has been inverted: you need to exchange it.
	The wiring to the earth is lacking or ineffective.
The burner goes to lock-out, after the pre-purge period, because the flame does not ignite.	The valves are passing too little gas ( <i>low pressure in the gas pipework</i> ).
	The valves are defective.
	It is irregular or the ignition arc is not present; in this case remove the control box and insert it again, taking care that the electrode push-rod is in the proper seat.
	The pipe has not been purged from the air.
The burner does not pass through the pre-purge period and the control box goes to lock-out.	The air pressure switch (A) does not change over: it has failed or the air pressure is too low ( <i>combustion head bad set</i> ).
	The air pressure is too high, verify: possible obstruction of the chimney or the pressure switch (B) has failed.
	Flame simulation exists ( <i>or the flame really lights</i> ).
The burner does not start at the thermostat closing.	Gas is not supplied.
	The gas pressure switch does not close its contact due to incorrect setting or a faulty switch.
	The air pressure switch (A) is changed over to the operational position.
	The damper actuator is failed.
	Before to replace the control box, check that short-circuits are not present on the power-line: of the motor, of the gas electrovalve/s and on the external signaling devices.
The burner continues to repeat the starting cycle without going on lock-out.	This concerns a very particular irregularity, caused by the fact that the gas pressure in the gas-mains lies very close to the value to which the gas pressure switch has been set.
	As a result of this, the sudden falling-off of pressure at the opening of the valves causes the opening of the pressure switch.
	However this only temporarily, because the valves immediately close again, so then does the pressure switch, because the pressure builds-up again the cycle to be repeated over and over.
	This can be remedied by lowering the setting of the pressure switch.

### OPERATING FAULTS

Re-cycle and lock-out may occur, because of : – Flame failure  
: – Ionization probe earthed

The burner goes to lock-out because of . . . . : – Opening of the air pressure switch

Burner stop because of . . . . . : – Gas pressure switch opening