

**powrmatic**



# The NV Range

## Users, Installation and Servicing Instructions

<b>TESTED</b>	
<b>STAGE 1</b>	<b>Full mechanical, construction, assembly and electrical sequence check</b> <input type="checkbox"/>
<b>STAGE 2</b>	<b>Full functional test in accordance with Quality System Procedures</b> <input type="checkbox"/>
<b>Heater Model</b> _____	<b>Final</b> <input type="checkbox"/>
<b>Heater Serial No.</b> _____	
<b>Type of Gas</b> _____	

**WARNING: THIS APPLIANCE MUST BE EARTHED**



# powrmatic

## Certificate of Guarantee



### Dear Customer

This is to certify that this appliance is guaranteed for two years including parts and labour from the date of original commissioning.

The heat exchanger, where fitted, is guaranteed (parts only) for a further eight years, chargeable on a sliding scale basis, price relative to age.

### To make a claim

In the first instance you must contact your appliance supplier, or installer and provide:-

1. The appliance type and serial number.
2. The original commissioning documentation.
3. As much detail as possible on the fault.

Your supplier, or installer will then contact Powrmatic to make a guarantee claim on your behalf.

### Conditions of Guarantee

1. The appliance must have been installed by a competent recognised installer, and in accordance with the manufacturers instructions, building regulations and local regulations.
2. The appliance has been professionally commissioned.
3. The appliance has been maintained on a yearly basis by a competent servicing company.
4. The appliance has been used in accordance with the manufacturers instructions.
5. The correct specification fuel has been used
6. No unauthorised repairs or modifications have been made.
7. Powrmatic 'General Conditions of Sale' have been observed.
8. Except for the obligation of Powrmatic Ltd to perform warranty repairs during the guarantee period, Powrmatic will not be liable in respect of any claim for direct or indirect consequential losses, including loss of profits or increased costs arising from loss of use of the appliance, or any event arising there from.

### Exclusions

1. Gaskets and fan belts are not included in the guarantee

---

Powrmatic Ltd, Hort Bridge, Ilminster, Somerset, TA19 9PS  
tel: 01460 53535 fax: 01460 52341  
web: [www.powrmatic.co.uk](http://www.powrmatic.co.uk)

**Important: This certificate must  
be kept with the appliance**

# Users Instructions

## 1. Checks before lighting the Air Heater

The following preliminary checks should be made before lighting the heater(s)

- a) Ensure that the ELECTRICAL supply to the heater is switched OFF.
- b) Check that all warm air delivery outlets are open.
- c) Check that the thermostat is set at MAX.
- d) Check that the clock control is set to an ON period.
- e) Check that any other controls are calling for heat.
- f) Ensure that the Summer/Winter switch is in the Winter position.
- g) Check that the overheat reset button has not operated.

## 2. Lighting the Air Heater

### NOTE:

On initial lighting of the heater(s), it may take some time to purge the internal pipework of air. If it is not possible to light the heater after several attempts contact the local service company.

1. Switch on the electrical supply at the isolator and the start up sequence will commence. The internal exhaust fan will run. When sufficient combustion airflow is proved by the air pressure switch the ignition spark will be generated and the main gas valves energized. The burners will then light.
2. If the burners fail to light the control box will go to lockout and the lockout light on the low level remote reset will be illuminated. To restart the ignition sequence depress the reset button on the low level reset for about 5 seconds. If the unit will not light after four or five attempts then shut down the unit and call in a service engineer.

## 3. To Shut Down the Air Heater

- 3.1 For Short Periods: Turn the room thermostat to the OFF or lowest setting.
- 3.2 For Long Periods: Complete step 3.1 above. Wait for 5 minutes and then turn OFF the electrical supply at the isolator.

## 4. Description of Operation

**Important:** All heaters must be controlled by the fitted external controls and not by use of the main switch in the electrical supply to the heater.

### 4.1 Standard Units

The ignition sequence will commence each time that the external controls e.g. Timeclock, room thermostat etc. call for heat. The heater fan will automatically start between 0 - 30seconds (depending on the setting of the internal timer) after the main burners light. When the external controls are satisfied the main burners will be turned off and approximately 2 - 3 minutes later the heater fan will be automatically stopped.

### 4.2 High / Lo & Modulating Units

When the main burners are alight the heat output will be controlled either to high fire or low fire or, in the case of modulating units, to any point between high and low fire; depending on the requirements of the space being heated and the external controls fitted.

### 4.3 Summer / Winter Modes

Certain types of external controls will provide for two modes of operation i.e.

Summer: The heater fan alone will run at the dictate of the

external controls to provide air movement.  
Winter: The heater will operate normally.

## 5. Maintenance

Regular servicing is essential to maintain efficient, reliable and safe operation of the heater. Users are strongly recommended to have the heater serviced by a qualified person at least annually and preferably at the end of the heating season.

## 6. IMPORTANT

Free access must be maintained to and around the heater for servicing purposes and the air supply to the heater must not be restricted in any way. Combustible materials must not be stored adjacent to the heater.

If at any time a gas leak is suspected turn OFF the gas supply - DO NOT USE A NAKED FLAME - and contact the local gas undertaking immediately.

All Powmatic heaters use gas and electricity to power them, they may also contain moving parts such as pulley belts. It would be hazardous to tamper with or attempt to service unless you are a competent person in the field of Gas and Electrical work.

If you have any safety questions reference the servicing and installation of any of our heaters please do not hesitate to contact our head office for expert advice.

Your safety is paramount to us.

### Gas Safety (Installation & Use) (Amendment) Regulations

It is law that all gas appliances are installed, adjusted and, if necessary, converted by qualified persons\* in accordance with the current issue of the above regulations. Failure to install appliances correctly can lead to prosecution. It is in your own interests and that of safety to ensure that the law is complied with.

\* e.g. Corgi Registered

# Installation & Servicing Instructions

## CONTENTS

<i>Section</i>	<i>Title</i>	<i>Page</i>
<b>1.</b>	<b>Introduction</b>	<b>1</b>
<b>2.</b>	<b>Technical Data</b>	<b>2</b>
<b>3.</b>	<b>General Requirements</b>	<b>5</b>
<b>4.</b>	<b>Installation</b>	<b>6</b>
<b>5.</b>	<b>Air Distribution System</b>	<b>9</b>
<b>6.</b>	<b>Commissioning &amp; Testing</b>	<b>9</b>
<b>7.</b>	<b>Servicing</b>	<b>11</b>
<b>8.</b>	<b>Connections to External Controls</b>	<b>13</b>
<b>9.</b>	<b>Fault Finding</b>	<b>14</b>
<b>10.</b>	<b>Short List of Parts</b>	<b>14</b>

<i>Tables</i>	<i>Title</i>	<i>Page</i>
<b>1.</b>	<b>Dimensions</b>	<b>3</b>
<b>2.</b>	<b>Specifications</b>	<b>3</b>
<b>3.1</b>	<b>Injector Sizes &amp; Burner Pressures Natural Gas - Group H - G20</b>	<b>4</b>
<b>3.2</b>	<b>Injector Sizes &amp; Burner Pressures Propane - G31</b>	<b>4</b>
<b>4.</b>	<b>Electrical Loadings 1ph</b>	<b>4</b>

<i>Figure</i>	<i>Title</i>	<i>Page</i>
<b>1a.</b>	<b>Exhaust only system - horizontal</b>	<b>8</b>
<b>1b.</b>	<b>Exhaust only system - vertical</b>	<b>8</b>
<b>2a.</b>	<b>Individual system - horizontal</b>	<b>8</b>
<b>2b.</b>	<b>Individual system - vertical</b>	<b>8</b>
<b>3a.</b>	<b>Concentric system - horizontal</b>	<b>8</b>
<b>3b.</b>	<b>Concentric system - vertical</b>	<b>8</b>
<b>4.</b>	<b>Controls Layout</b>	<b>10</b>
<b>5.</b>	<b>Governor adjustment (Honeywell VR425A)</b>	<b>10</b>
<b>6.</b>	<b>Governor adjustment (Honeywell VR4605A)</b>	<b>10</b>
<b>7.</b>	<b>High/Lo and Modulating Heads</b>	<b>11</b>
<b>8.</b>	<b>Ignition Electrode Spark Gap</b>	<b>11</b>

## 1. INTRODUCTION

The NV range are highly efficient gas fired, fanned circulation air heaters that cover heat outputs of 10kW to 140kW, have a closed combustion circuit and are supplied complete with a flue system. They are certified for use on Natural Gas, Group H - G20, and Propane - G31 only.

Appliance Categories are Cat II2H3P (GB, IE).

The heaters are designed to be suspended from suitable roof points or alternatively to be mounted on purpose designed brackets and are intended primarily for heating commercial or industrial premises. They may be used where the atmosphere inside the premises could be contaminated e.g. Dust, oil mist etc. but the heaters are not airtight and therefore may not be used in areas classified as hazardous as defined in BS 5345: Part 2 or areas subjected to significant negative pressures due to extract systems.

NV/F heaters have an axial fan assembly fitted at the rear to circulate the air being heated through the folded tube heat exchanger. NV/C units are supplied with a centrifugal fan/silencer duct section and NV/D units for use with ducted systems where the air moving fan is by others or a centrifugal fan section is used remote from the heater. The NV/DH units are for use in air handling units.

Heaters are fitted as standard with atmospheric inshot burners, a fully automatic control for ignition, flame sensing, gas supply control and safety functions, an internal exhaust fan, main air fan (/F and /C models), fan timer, high temperature thermostat and limit thermostat.

Options include HIGH/LOW or modulating burner controls, inlet duct connection, outlet duct connection, 45° head, 90° outlet bend, vertical/horizontal outlet louvre assembly and a full range of modular duct components.

### **Gas Safety (Installation & Use) Regulations**

It is law that all gas appliances are installed, adjusted and, if necessary, converted by qualified persons\* in accordance with the current issue of the above regulations. Failure to install appliances correctly can lead to prosecution. It is in your own interests and that of safety to ensure that the law is complied with.

\* e.g. Corgi Registered

## 2. TECHNICAL DATA

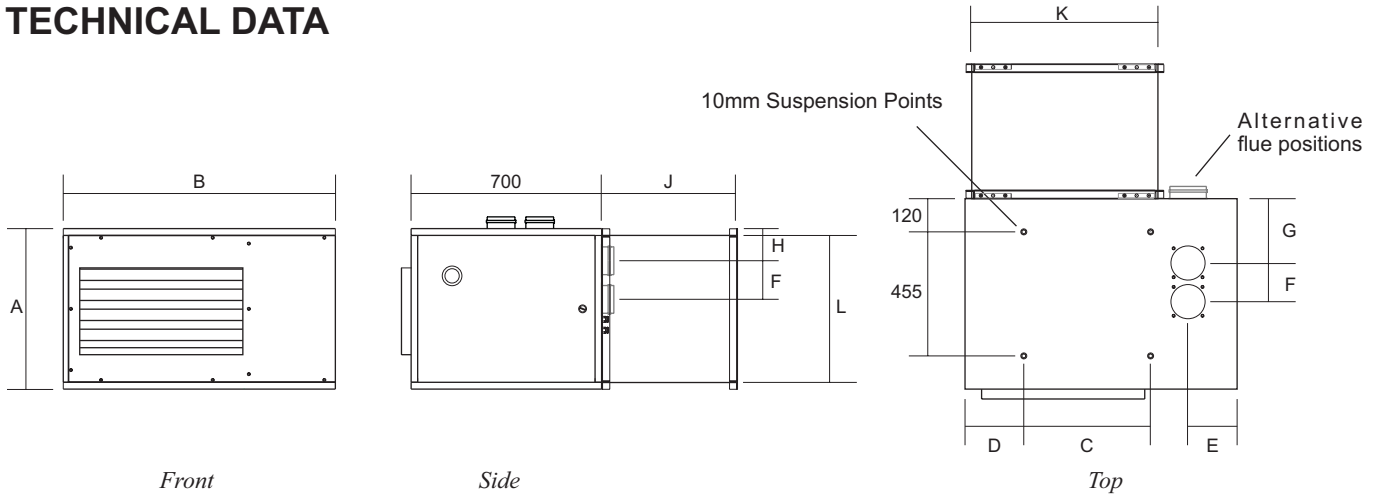

**NV20/D WITH CENTRIFUGAL FAN/SILENCER SECTION SHOWN**

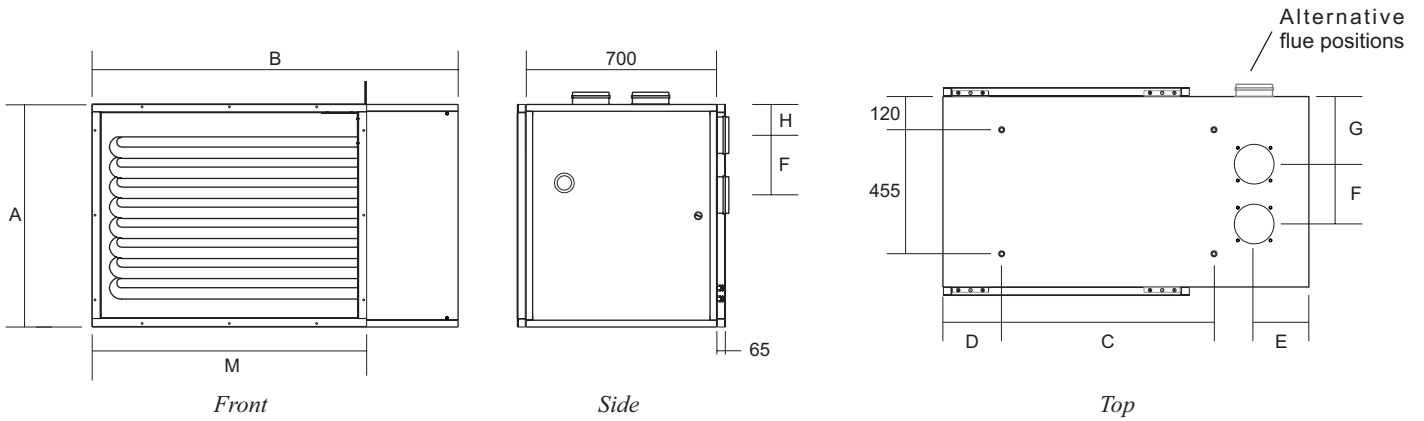

**NV60/D SHOWN**

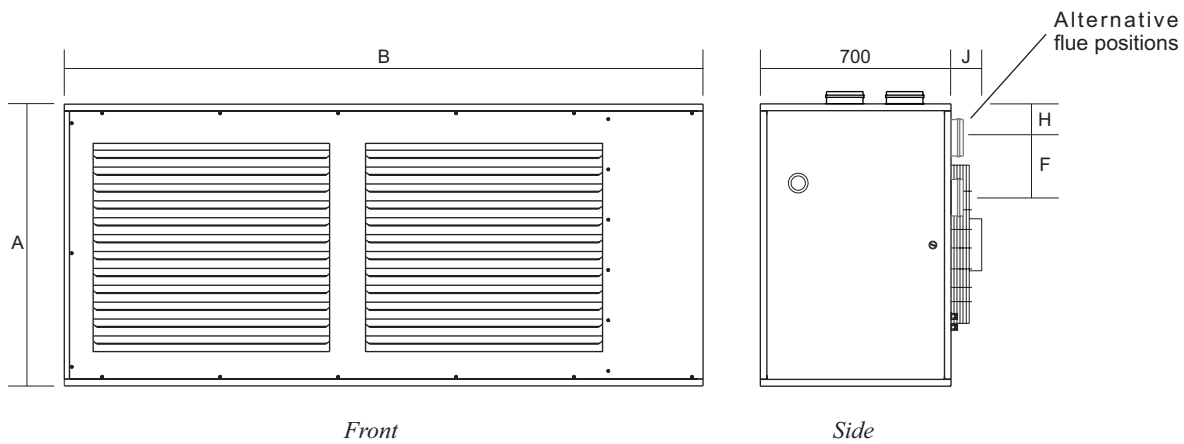

**NV140/F SHOWN**

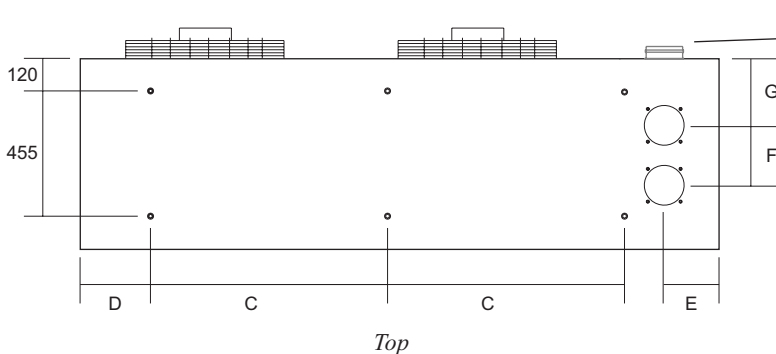

**Table 1. Dimensions**

Model	A	B	C	D	E	F	G	H	J	K	L	M	N	O	P	Q	Flue Ø (mm)																
NV10	590	750	296	192	181	120	262.5	109	750	436	524	502	116	189	83	510	80																
NV15		1000	506	176				172.5		142		236.5						118	631	697	151	227											
NV20																							818	1345	740	248.5	123.5	944	1010	146	151	738	100
NV25																																	
NV30	818	705	258	202	220	639	1948	2014		88	153	624																					
NV35	970	870	258	202	220	804								1948		2014	88	153	789														
NV40	1035	870	258	202	220	969	1948	2014		88	153	954																					
NV50	818	705	258	202	220	639								1948		2014	88	153	624														
NV60	970	870	258	202	220	804	1948	2014		88	153	789																					
NV75	1035	870	258	202	220	969								1948		2014	88	153	954														
NV90	818	705	258	202	220	639	1948	2014	88	153	624																						
NV120	970	870	258	202	220	804						1948	2014	88	153	789																	
NV140	1035	870	258	202	220	969	1948	2014	88	153	954																						

**Table 2 - Specifications**

MODEL	HIGH FIRE		LOW FIRE		AIR VOLUME	MAXIMUM DUCT RESISTANCE	FAN MOTOR	NOISE LEVEL	WEIGHT	
	INPUT (Nett)	OUTPUT	INPUT (Nett)	OUTPUT						
	kW		kW							m³/s
NV10	F	10.79	10.0	6.57	5.90	0.2601	N/A	0.040	46	53
	D						140	0.250	N/A	91.5
NV15	F	16.00	15.0	8.22	7.50	0.3902	N/A	0.120	54	54
	D						145	0.370	N/A	106.5
NV20	F	21.85	20.0	11.58	9.92	0.5203	N/A	0.070	52	68
	D						177	0.370	N/A	120.5
NV25	F	27.32	25.0	16.50	14.30	0.6503	N/A	0.180	53	89
	D						143	0.370	N/A	126.5
NV30	F	32.60	30.0	18.34	16.30	0.7804	N/A	0.180	54	89
	D						250	1.100	N/A	166.5
NV35	F	39.32	35.0	23.1	19.0	1.000	N/A	0.300	58	89
	D						210	1.100	N/A	166.5
NV40	F	43.48	40.0	24.19	21.22	1.0405	N/A	0.300	58	93
	D						236	1.100	N/A	168.5
NV50	F	54.23	50.0	28.40	24.83	1.3006	N/A	0.440	61	114
	D						205	1.100	N/A	183
NV60	F	65.22	60.0	35.63	31.49	1.5608	N/A	0.550	62	130
	D						250	1.50	N/A	213
NV75	F	81.25	75.0	42.61	37.50	1.9510	N/A	0.550	62	150
	D						260	1.50	N/A	234
NV90	F	95.25	90.0	58.50	54.50	2.3412	N/A	2 x 0.440	66	188
	D						200	2 x 1.10	N/A	343
NV120	F	126.32	120.0	75.45	71.00	3.1215	N/A	2 x 0.550	67	260
	D						284	2 x 1.50	N/A	363.5
NV140	F	148.93	140.0	98.92	92.55	3.6418	N/A	2 x 0.550	67	260
	D						285	2 x 1.50	N/A	424

Note: /D data refers to Powrmatic supplied centrifugal/silencer duct section

**Table 3.1**

**Injector Sizes & Burner Pressures Natural Gas - Group H - G20 Net CV (Hi) = 34.02MJ/m<sup>3</sup>**

Inlet Pressure 20mb	INJECTORS			High Fire		Low Fire	
				Burner Pressure	Gas Rate	Burner Pressure	Gas Rate
MODEL	No.	Size mm	Marked	mbar	m <sup>3</sup> /h	mbar	m <sup>3</sup> /h
NV10	4	1.36	240	13.2	1.14	5.3	0.70
NV15	4	1.67	380	12.5	1.69	3.5	0.87
NV20	4	1.94	500	12.7	2.31	4.0	1.23
NV25	5	1.94	500	12.5	2.89	4.7	1.75
NV30	6	1.94	500	11.9	3.45	4.0	1.94
NV35	6	2.26	580	12.7	4.16	4.1	2.44
NV40	8	1.94	500	12.7	4.60	4.0	2.56
NV50	10	1.94	500	13.2	5.74	4.0	3.01
NV60	8	2.54	750	9.5	6.90	2.7	3.77
NV75	10	2.54	750	9.5	8.60	2.9	4.51
NV90	6	3.5	1500	9.1	10.08	3.5	6.19
NV120	8	3.5	1500	9.1	13.37	3.4	7.98
NV140	10	3.5	1500	8.4	15.76	4.0	10.47

Inlet pressure  
20mbar

**Table 3.2**

**Injector Sizes & Burner Pressures - Propane G31 - Net CV (Hi) = 88.00MJ/m<sup>3</sup>**

Inlet Pressure 37mb	INJECTORS			High Fire		Low Fire	
				Burner Pressure	Gas Rate	Burner Pressure	Gas Rate
MODEL	No.	Size mm	Marked	mbar	m <sup>3</sup> /h	mbar	m <sup>3</sup> /h
NV10	4	0.90	90	28.0	0.44	10.0	0.27
NV15	4	1.10	110	28.5	0.65	10.0	0.34
NV20	4	1.25	125	31.0	0.89	9.9	0.47
NV25	5	1.25	125	30.6	1.12	11.5	0.67
NV30	6	1.25	125	27.0	1.33	10.0	0.75
NV35	6	1.36	136	20.5	1.61	9.2	0.95
NV40	8	1.25	125	28.5	1.78	10.0	0.99
NV50	10	1.25	125	29.2	2.22	9.7	1.16
NV60	8	1.55	155	27.0	2.67	10.0	1.46
NV75	10	1.55	155	27.0	3.32	10.0	1.74
NV90	6	2.10	210	26.3	3.90	9.8	2.39
NV120	8	2.10	210	27.0	5.17	10.0	3.09
NV140	10	2.10	210	26.1	6.09	9.5	4.04

Inlet Pressure  
37mbar

**Table 4**

**Electrical Loadings 1ph**

MODEL	/F Models					Centrifugal Fan Sections				
	NOMINAL MOTOR R.P.M.	PLATE AMPS (A)	START AMPS (A)	RUN AMPS (A)	FUSE RATING (A)	NOMINAL MOTOR R.P.M.	PLATE AMPS (A)	START AMPS (A)	RUN AMPS (A)	FUSE RATING (A)
NV10	900	0.18	0.34	0.16	2	900	2.8	4.2	2.10	3
NV15	1400	0.54	1.39	0.51			4.0	8.1	2.60	
NV20	775	0.31	0.38	0.28			4.0	7.8	3.20	5
NV25	910	0.89	1.89	0.62			4.0	8.2	2.90	
NV30			1.83	0.61	8.4		14.7	4.50		
NV35	870	1.30	2.56	1.35			14.5	5.00	7	
NV40			2.56	1.35			14.0	5.30		
NV50	820	1.40	4.01	1.96	3		16.0	6.40		
NV60			2.50	4.70			2.44	24.5	10.6	
NV75		4.78		2.51			24.5	12.3	16	
NV90		2 x 1.40	7.81	4.22	5	2 x 8.4	28.4	11.6		
NV120		2 x 2.50	9.57	5.13	7	2 x 11.1	42.5	21.5	25	
NV140	9.64						4.98	39.8		25.2

Note: 3ph Data is supplied seperately with units ordered to this specification.



## 3. General Requirements

### 3.1 Related Documents

The installation of the air heater(s) must be in accordance with the rules in force and the relevant requirements of the Gas Safety Regulations, Building Regulations and the I.E.E. Regulations for Electrical Installations.

It should also be in accordance with any relevant requirements of the local gas region, local authority and fire authority and the relevant recommendations of the following documents.

Institution of Gas Engineers & Managers

IGE/UP/1 (Ed.2) Strength and tightness testing and purging of industrial and commercial gas installations.

IGE/UP/1A Soundness testing and direct purging of small low pressure industrial and commercial gas installations.

IGE/UP/2 Gas installation pipework, boosters and compressors on industrial and commercial premises.

IGE/UP/10 Installation gas appliances in industrial and commercial premises.

British Standards Code of Practice

BS 5588 Fire precautions in the design and construction of buildings.

Part 2 : 1985 Code of Practice for Shops

Part 3 : 1983 Code of Practice for Office Buildings

BS 6230: 1991 Installation of Gas Fired Forced Convection Air Heaters for Commercial and Industrial Space Heating.

Those appliances having a gross input rating not exceeding 60kW viz. NV10 to NV50 inclusive and installed so as to take their combustion air from within the building must be installed in accordance with the relevant recommendations of the following document.

BS 5440 Flues and Air Supply for gas appliances of rated input not exceeding 60kW (1st and 2nd family gases), Part 2 - Air Supply

For NV/D units of 10 - 50 size, reference should also be made to

BS 5864. Code of Practice for installation of gas-fired ducted-air heaters of rated input not exceeding 60kW.

#### 3.2 Location

The location chosen for the air heater must permit:  
- the provision of a satisfactory flue system and an adequate air supply.

- adequate space for servicing and air circulation around the air heater.

The heater(s) must not be installed in conditions for which it is not specifically designed e.g. where the atmosphere is corrosive or salty, and they are not suitable for outdoor use. Where the location of the air heater is such that it might suffer external mechanical damage e.g. from overhead cranes, fork lift trucks, it must be suitably protected.

NV units are designed to operate within an ambient temperature range of -10 to 25°C.

### 3.3 Gas Supply

#### 3.3.1 Service Pipes

The local gas undertaking should be consulted at the installation planning stage in order to establish the availability of an adequate supply of gas. An existing service pipe must not be used without prior consultation with the local gas undertaking.

#### 3.3.2 Meters

A gas meter is connected to the service pipe by the local gas undertaking or a local gas undertaking contractor. An existing meter should be checked, preferably by the gas undertaking, to ensure that the meter is adequate to deal with the total rate of gas supply required.

#### 3.3.3. Installation Pipes

Installation pipes should be fitted in accordance with IGE/UP/2. Pipework from the meter to the air heater must be of adequate size. Do not use pipes of a smaller size than the inlet gas connection of the heater. The complete installation must be tested for soundness as described in the above Code.

#### 3.3.4. Boosted Supplies

Where it is necessary to employ a gas pressure booster the controls must include a low pressure cut off switch at the booster inlet. The local gas undertaking must be consulted before a gas pressure booster is fitted.

### 3.4 Flue System

NV units feature a closed combustion circuit and have an internal exhaust fan, mounted downstream of the heat exchanger, to both assist the evacuation of the products of combustion and to draw in air for combustion.

The air heater must be connected to the flue system that is provided by Powmatic Ltd. Several configurations of flue and combustion air ducts are available as shown diagrammatically (*See Page 8 Figs 1a to 3b*).

The flue should terminate in a freely exposed position and must be so situated as to prevent the products of combustion entering any opening in a building in such concentration as to be prejudicial to health or a nuisance.

### 3.5 Combustion Air Supply

When the combustion air inlet duct is terminated within the space being heated then for buildings having a design air change rate of less than 0.5/h, and where NV units are to be installed in heated spaces having a volume less than 4.7 m<sup>3</sup>/kW of total rated heat input grilles shall be provided at low level as follows:-

(1) for heaters of heat input less than 60 kW, the total minimum free area shall not be less than 4.5 cm<sup>2</sup> per kilowatt of rated heat input.

(2) for heaters of heat input 60 kW or more, the total minimum free area shall not be less than 270cm<sup>2</sup> plus 2.25 cm<sup>2</sup> per kilowatt in excess of 60 kW rated heat input.

Where the air heater(s) are to be installed in a plant room the plant room must have permanent air vents communicating directly with the outside air, at high level and at low level.

Where communication with the outside air is possible only by means of high level air vents, ducting down to floor level for the lower vents should be used.

All air vents should have negligible resistance and must not be sited in any position where they are likely to be easily blocked or flooded or in any position adjacent to an extraction system which is carrying flammable vapour.

Grilles or louvres should be so designed that high velocity air streams do not occur within the plant room.

The basic minimum effective area requirements of the air vents are as follows:

(a) Low Level (inlet)

(1) for heaters of total rated heat input less than 60kW: 9cm<sup>2</sup> per kilowatt of rated heat input.

(2) for heaters of total rated heat input 60kW or more: 540 cm<sup>2</sup> plus 4.5 cm<sup>2</sup> per kilowatt in excess of 60 kW total rated input.

- (b) High Level (outlet)
- (1) for heaters of total rated heat input less than 60kW: 4.5cm<sup>2</sup> per kilowatt of rated heat input.
  - (2) for heaters of total rated heat input 60kW or more: 270 cm<sup>2</sup> plus 2.25 cm<sup>2</sup> per kilowatt in excess of 60kW total rated input.

### 3.6 Air Distribution System

For free-blowing units used in buildings having a low heat loss i.e. where single units are required to cover a large floor area, and in buildings with high roof or ceiling heights Calecon thermal economiser units should be fitted to ensure even heat distribution and minimise stratification.

Care should be taken to avoid impeding the air throw with racking, partitions, plant or machinery etc. Various outlet configurations are available as optional extras to modify the air throw pattern to suit particular site conditions.

For ducted units all delivery and return air ducts, including air filters, jointing and any insulation or lining must be constructed entirely of materials which will not contribute to a fire, are of adequate strength and dimensionally stable for the maximum internal and external temperatures to which they are to be exposed during commissioning and normal operation. Where inter-joint spaces are used as duct routes they should be suitably lined with a fire-resisting material.

A full and unobstructed return air path to the air heater(s) must be provided.

If the air heater(s) is installed in a plant room the return air intake(s) and the warm air outlet(s) from the heater(s) must be fully ducted, into and out of the plant room to avoid interference with the operation of the heater.

The openings in the structure of the plant room through which the ducting passes must be fire stopped.

Care must be taken to ensure that return-air intakes are kept clear of sources of smells and fumes, and where there is any possibility of pollution of the air by dust, shavings etc., precautions must be taken to prevent contamination. If necessary suitable barrier rails should be provided to prevent any combustible material being placed within 900mm of the outlets.

### 3.7 Electrical Supply

Wiring external to the air heater must be installed in accordance with the I.E.E. Regulations for Electrical Installations and any local regulations which apply. Wiring should be completed in flexible conduit.

All standard heaters are supplied by 230V - 1ph, 50Hz. The method of connection to the main electricity supply must:-

- facilitate the complete electrical isolation of the unit(s)
- be in a readily accessible position adjacent to the unit(s)
- serve only the unit(s)
- have a contact separation of at least 3mm in all poles. See the accompanying wiring diagram for the heater electrical connections

NV centrifugal fan/silencer units can also be supplied for 400V 3N, 50Hz.

## 4. Installation of Air Heater(s)

### 4.1 General

Before installation, check that the local distribution conditions, nature of gas and pressure, and adjustment of the appliance are compatible.

The air heater must be installed in accordance with the rules in force and the relevant requirements of any fire regulations or insurance company's requirements appertaining to the area in

which the heater is located, particularly where special risks are involved such as areas where petrol vehicles are housed, where cellulose spraying is carried out, in wood working departments etc.

NV/C units are supplied with the centrifugal fan/silencer section separate from the heater. This section must be fitted at the rear of the NV heater i.e the fan is blowing across the heat exchanger. Whichever method of mounting the air heater is used the following minimum clearances for installation and servicing must be observed.

RHS Clearance (looking at front of heater)	1.0m
LHS Clearance (looking at front of heater)	0.2m
Top of the heater to ceiling	0.2m
Rear of heater to nearest wall	0.6m

(Depending on flue system used)

For multi air heater installations the following minimum distances between units must be observed.

Between units, side to side	3.0m
Between units, back to back	3.0m

Recommended mounting heights, floor level to the underside of the unit, are:-

NV10F - 30F	2.5m - 3m
NV40F - 150F	3m - 5m
NV/D Models	Recommended mounting heights not applicable

All models must not be installed at a height of less than 2.5m to the base of the unit.

Any combustible material adjacent to the air heater and the flue system must be so placed or shielded as to ensure that its temperature does not exceed 65 °C.

When NV modular components are used in conjunction with the heater each component must be individually supported.

#### IMPORTANT:

1. Heaters shall not be installed in:-
  - a) Those parts of spaces within buildings that have been classified as hazardous areas as defined in BS 5345 : Part 2.
  - b) Where there is a foreseeable risk of flammable particles or gases or corrosion inducing gases or vapours being drawn into either the heated air stream or the air for combustion. In such cases installation may only proceed if the air to be heated is ducted to the heater from an uncontaminated source, preferably from outside the building. The option of taking combustion air from the space is not permitted. In certain situations where only airborne particles are present it may suffice to fit filters on the main air inlet duct of the heater. Advice in these instances may be obtained from Powrmatic Ltd.
  - c) In areas subjected to significant negative pressures due to extract systems.

### 4.2 Fitting the Air Heater

The air heater may be installed either:

- a) suspended from suitable vertical drop rods, chains or straps.
- b) on specifically designed cantilever brackets from a non-combustible wall.
- c) on a level non-combustible surface providing the surface does not extend past the front edge of the heater. Whatever method of installation is used it must be capable of adequately supporting the weight of the unit (*See Table 2, Page 3*) and any ancillary equipment. Before installing the heater the existing structure must be inspected to ensure it is suitable. All supports should be protected against the effects of rust or corrosion.

If noise levels are of particular importance the heater should be insulated from the structure by installing it on suitable anti-vibration mountings. In all such cases and when the heater is

suspended it is essential that all gas, duct, and electrical connections to the heater are made with flexible connections to maintain continuity of connection.

## 4.3 Flue/Combustion Air Duct System

All models are supplied as standard with a top flue outlet and the flue outlet and combustion air sockets are loose inside the controls section.

### 4.3.1.1. Conversion to Rear Flue Outlet

1. Remove the two blanking plates from the flue /combustion air openings at the rear of the unit.
2. Remove the four screws from the exhaust fan outlet flange.
3. Remove the two screws at the left hand side of the fan mounting plate that secure it to the exhaust header.
4. Remove fan assembly by pulling forwards and to the left to disengage the retaining lugs.
5. Rotate the fan assembly 90° clockwise. Remove the fixing plate from the top of the fan box and reposition on the left hand side. The screws from the left hand side are refitted at the top to close off the open holes. Ensure that the gasket around the inlet to the fan is not damaged, if necessary replace or make good with silicon sealant.
6. Engage the locating lugs on the right hand side of the fan box into the slots on the collector box, push fan against collector box and secure with the two screws at the left hand side.

### 4.3.1.2 Fitting Flue/Combustion Air Sockets

1. Apply a bead of silicon sealant around the face of the flange on the exhaust fan outlet tube that can be seen from the outside of the heater. Place the flue socket on the outside of the heater to mate with this flange and clamp the two flanges together, on either side of the heater panel using the screws provided. Ensure that the silicon sealant has sealed between the two flanges.
2. Apply a bead of silicon sealant around the face of the flange of the combustion air socket, on the same side as the socket. Passing the socket through the panel from the inside, position the flange up against the panel. Secure, from the outside, with the screws provided.
3. If ducted combustion air is not required (*see Section 3.5*) fit the mesh inlet plate behind the unused combustion air inlet hole.
4. Apply silicon sealant and refit blanking plates as required to seal unused panel holes.

### 4.3.2. General Requirements

See Figures 1a to 3b for the different types of flue installation. In all cases the flue outlet socket must be connected via the provided flue system to outside air. The maximum permitted length of flue system is 6m, or 12m if the flue outlet only is used. If an offset is required two sets of 45° bends may be used each set being equivalent to 0.5m of flue length. The minimum flue length (end of flue terminal to back or top of heater) shall not be less than 1.0m for the NV10 - 50 and 1.3m for the NV60 - 140.

All outer joints must be finished with the provided locking bands. A smear of silicon grease to the inside of sockets will assist in fitting components together. All flue and combustion air ducts must be supported independently of the air heater. The flue or flue/combustion air terminal must not be installed so as to be less than:

- 300mm below an opening e.g. window, air brick etc.
- 200mm below eaves or gutter.
- 300mm from an internal or external corner.
- 1200mm from a surface facing the terminal.
- 1500mm vertically from another terminal on the same wall.
- 300mm horizontally from another terminal on the same wall.
- 2000mm from ground level.

## 4.3.3 Installation of Flue System

**Note:** A terminal guard, as supplied by Powrmatic Ltd, must be fitted to horizontal flue terminals.

### 4.3.3.1 Horizontal System - Rear Outlet

**Note:** If the outlet is required to the side of the unit 90° bends may be fitted directly onto the inlet/outlet spigots on the heater.

1. Locate the position of the flue terminal, allowing for a slight gradient running down from the heater to the terminal of 2° - 3° and cut a hole to suit.
2. Fit the flue terminal, securing via the wall plate and weather with silicon sealant or similar.
3. Fit the twin to concentric adaptor to the terminal section and extend the flue and combustion air ducts to the heater using straight lengths. Fit an adjustable length prior to the unit, to facilitate flue disconnection for servicing. Extend the adjustable lengths to make the final connection to the appropriate heater inlet/outlet spigots.
4. Ensure that internal silicon sealing rings are in place and that all tubes are pushed fully home. Secure concentric lengths with the locking bands provided.

### 4.3.3.2 Vertical System - Top Outlet

1. Locate the position of the flue terminal cut a hole in the roof to suit.
  2. Fit the flashing and the flue terminal so that the lower edge of the outer case is over the top of the flashing. Weather with silicon sealant or similar.
- Fit a condensate drain length into the flue socket on the heater and an equivalent straight length onto the combustion air socket.
3. Fit the twin to concentric adaptor to the terminal section and then extend down to the heater using straight lengths. Fit adjustable lengths as the final connection pieces, to facilitate flue disconnection for servicing. Extend the adjustable lengths to make the final connection but do not exceed the maximum extended length so as to maintain joint integrity. Extend the drainage offtake of the condensate drainage length to a suitable gully or drain.
  4. Ensure that internal silicon sealing rings are in place and that all tubes are pushed fully home. Secure concentric lengths with the locking bands provided.

### 4.3.3.3 Internal Combustion Air Systems

1. Complete the run of flue sections from the terminal spigot to the flue outlet socket of the heater generally as described in 4.3.3.1 and 4.3.3.2, ensuring that the internal silicon sealing rings are in place.
2. For top air inlet units ensure that the mesh inlet plate has been fitted (*see 4.3.1.2*). For rear air inlet units it is recommended that a 90° bend is fitted the open end of which faces to the side of the heater i.e. away from the main air fan.

## 4.4 Gas Connection

Solid pipework must be fitted to the internal gas control and exit through the heater casing and then be fitted with a servicing valve and union to facilitate servicing. The gas supply to the air heater must be completed in solid pipe work and be adequately supported. Heaters suspended by drop rods, straps or chains must have a flexible connection as the final link between the gas supply pipe work and the heater. Sufficient slack must be left in the connection to take account of normal movement of the heater.

### Warning

When completing the final gas connection to the heater do not place undue strain on the gas pipe work of the heater.

## 4.5 Electrical Connections

**Fig 1a Exhaust only system - horizontal**

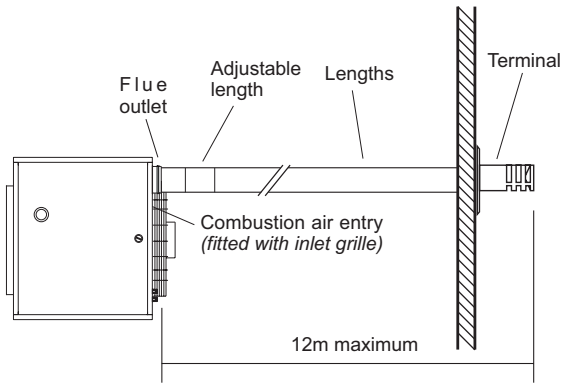

**Fig 1b Exhaust only system - vertical**

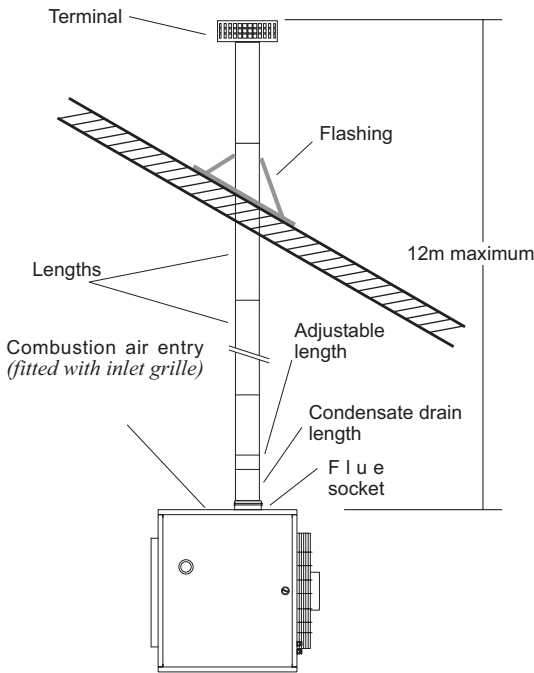

**Fig 2a Individual system - horizontal**

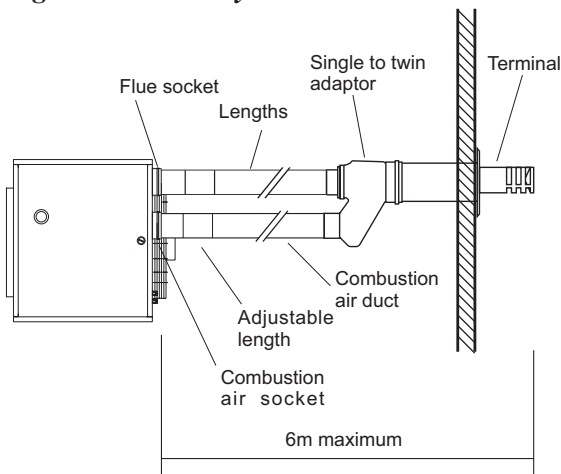

**Fig 2b Individual system - vertical**

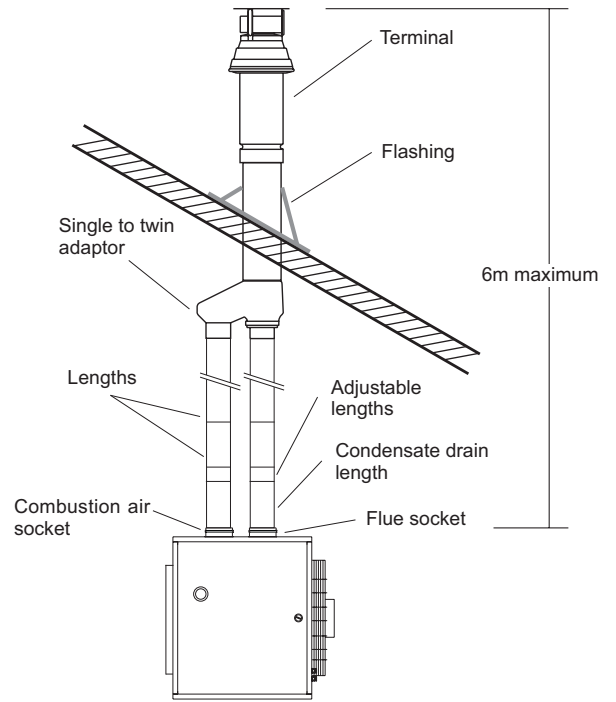

**Fig 3a Concentric system - horizontal**

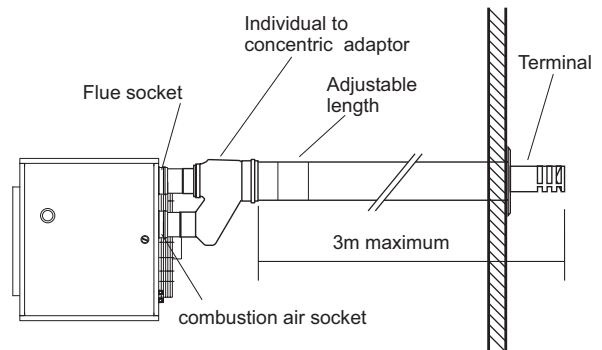

**Fig 3b Concentric system - vertical**

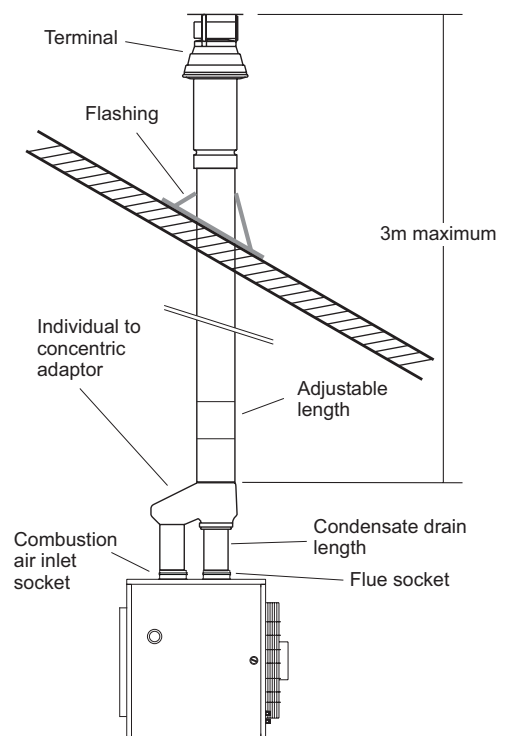

Notes for all systems.

- i) Final overall length of adjustable disconnection piece must be between 360 - 415mm.
- ii) 45° offsets may be used if required. Each set is equivalent to 0.5m of flue length.
- iii) Where NV heaters are used in clean environments it is permissible to take the combustion air directly from the heated space. The supplied mesh intake plate, must be fitted to the combustion air inlet on the rear of the heater.

All units, with the exception of NV/D units supplied with a centrifugal fan/silencer duct section, are fully prewired and only require final connections for the incoming mains supply and completion of the control circuit (230V) via a room thermostat, time clock etc. and the remote low level lockout reset. **Warning:** Lockout reset is by a switched Neutral to the controls in the heater.

All units must be earthed. The electrical supply must be run to a point adjacent to the heater and be suitably terminated to provide an isolation point that will prevent remote activation of the unit during servicing. See Table 4 (Page 4) to ascertain the electrical loading of the unit(s) so that cables of adequate cross-sectional area are used for the electrical installation. The length of the conductors between the cord anchorage and the terminals must be such that the current carrying conductors become taut before the earth conductor if the cable or cord slips out of the cord anchorage. All external controls must be of an approved type.

See the wiring diagram accompanying these instructions. NV/D models supplied with a centrifugal fan/silencer duct section require wiring to be completed between the heater and fan. Refer to supplied wiring diagram.

NV/D models supplied less fan must be electrically interlocked to the air movement system so that this is started in the same manner as the air heater fan would be viz. A connection from the heater terminal marked "Live Main Fan" must be made to one side of the fan motor contactor coil, the other side of the coil being connected to Neutral. The fan motor electrical supply must not be taken direct from the internal wiring of the NV heater.

## 5. Air Distribution System

### 5.1 General

NV/D models are designed for use with duct work to more precisely define the point of air delivery, and/or provide ducted return air or ducted fresh air inlet. All ducting must be independently supported of the air heater.

Joints and seams of supply ducts and fittings must be securely fastened and made airtight. If required the ductwork should be insulated to reduce heat loss.

### 5.2 Noise Reduction

Ducting should be connected to the heater spigots via an airtight flexible coupling of non-combustible material. Before fitting the coupling it must be ensured that a minimum clearance of approximately 15mm will be maintained between the ends of the ducting and the heater spigots.

Sound attenuators may be fitted in inlet and outlet ducts to reduce airborne fan noise. Materials used in outlet sound attenuators must be capable of withstanding 100°C air temperature without any deterioration.

### 5.3 Room Thermostat Siting

The room thermostat should be fitted at a point which will be generally representative of the heated area as far as temperature is concerned. Draughty areas, areas subjected to direct heat e.g. from the sun, and areas where the air movement is relatively stagnant e.g. in recesses, are all positions to be avoided for siting the thermostat.

The thermostat should be mounted about 1.5m from the floor. Any room thermostat, frost thermostat, time clock etc. must be suitable for switching 230V, 5A and must be of the 'snap action' type to minimise contact bounce.

For electrical connections of external controls see the accompanying wiring diagram.

## 6. Commissioning & Testing

### 6.1 Electrical Installation

Checks to ensure electrical safety must be carried out by a qualified person.

### 6.2 Gas Installation

The whole of the gas installation, including the meter, should be inspected and tested for soundness and purged in accordance with the recommendations of IGE/UP/1 (Edition 2) or IGE/UP/2A as appropriate.

### 6.3 Air Distribution System

The system should be checked to ensure that the installation work has been carried out in accordance with the design requirements.

Particular attention should be given to the correct arrangement of delivery ducts and registers, return air ducts and grills and general adequacy of return air paths.

For NV/D units ensure that the ductwork is balanced so that the specified motor running currents are achieved.

### 6.4 Checks before lighting the Air Heater

The following preliminary checks should be made before lighting the heater(s)

- Ensure that the ELECTRICAL supply to the heater is switched OFF.
- Check that all warm air delivery outlets are open.
- Check that the thermostat is set at MAX.
- Check that the clock control is set to an ON period.
- Check that any other controls are calling for heat.
- If a Eurotrol or Powrtrol is being used ensure that the Summer/Winter switch is in the Winter position.
- Check that the overheat reset button has not operated.

### 6.5 Lighting the Air Heater

#### NOTES:

1. On initial lighting of the heater(s), it may take some time to purge the internal pipework of air.

#### IMPORTANT:

The internal pipework of the appliance has been tested for soundness before leaving the factory. After establishing the main burners test round the gas inlet connection using a leak detection fluid e.g. soap solution.

#### 6.5.1 All Models

1. Switch on the electrical supply at the isolator and the ignition sequence will commence. After a delay of approximately 45 seconds the ignition spark will be generated and the main gas valves energized. The burners will then light.

2. If the burners fail to light the control box will go to lockout and the lockout light on the internal pcb will be illuminated. To restart the ignition sequence depress the reset button adjacent to the lockout light for about 5 seconds.

**Note:** A secondary red LED mounted on the pcb surface signals as follows

- 1 flash at power up as voltage is stabilising
- 1 Hz flash signals safety shut down or over voltage greater than 260V. If the heater is running and the air pressure signal is lost the LED will flash at 1Hz. If the air pressure signal then re-establishes the unit will restart after approximately six minutes. If, when the air pressure signal is lost, the unit is turned off and then back on the normal startup sequence will take place.
- 2Hz flash signals undervoltage, less than 200V

**Figure 4 General Controls Layout**

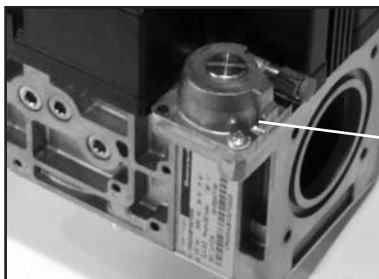
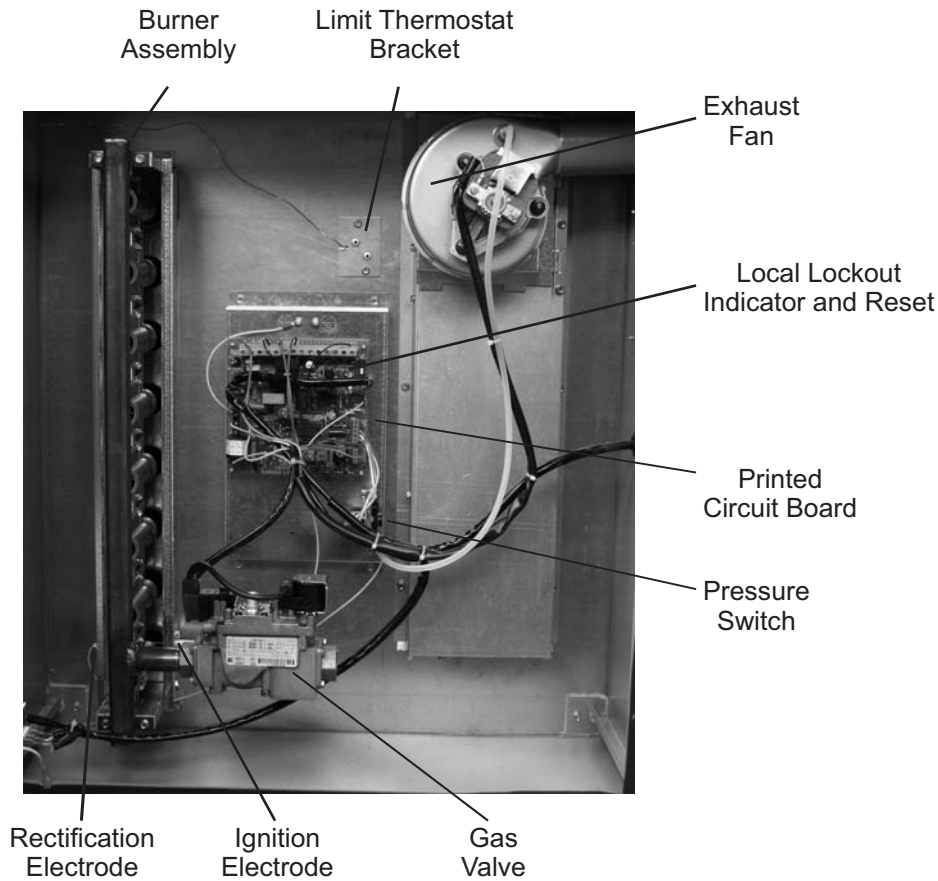

**Figure 5**  
Governor adjustment screw under cover cap (Honeywell VR425AB1007)

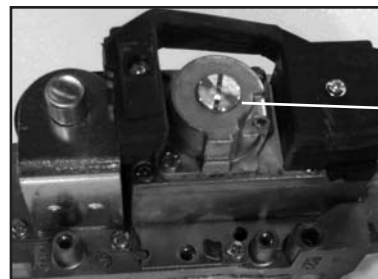

**Figure 6**  
Governor adjustment screw under cover cap (Honeywell VR4605A B1027)

**3. SHUT OFF**

Switch OFF the electrical supply to the heater or set the clock control to OFF or set the room thermostat to MIN.

**6.6 Adjustments**

**6.6.1 Burner Gas Pressure**

This is set for the required heat input before despatch. In the case of Hi/Lo and Modulating units both high and low pressures are set. Pressures should be checked in the following manner.

**6.6.1.1 Standard Units**

1. Set external controls to ensure that the main burner is off. Open the side access door. Connect a pressure gauge to the burner pressure test point on the multifunctional control.
2. Set external controls so as to turn on the main burner. Compare

the measured burner gas pressure to that stated on the data plate. If necessary adjust the burner gas pressure by turning the regulator screw anticlockwise to decrease the pressure, or clockwise to increase the pressure.

3. In addition it is advisable to check the gas rate using the gas meter dial pointer. Ensure that no other appliances supplied through the meter are in operation.

If required, after checking or setting the burner pressures, the CO<sub>2</sub> content in the flue gases can be checked by sampling in the first section of flue fitted to the flue outlet of the unit. Nominal CO<sub>2</sub> values are given for guidance in the Table at the bottom of the page.

5. Turn off the main burner as in 6.5.1. and disconnect the pressure gauge and replace the sealing screw. Turn on the main burner as above and test for gas soundness around pressure test joint using a leak detection fluid e.g. soap solution.

Model	NV 10	NV 15	NV 20	NV 25	NV 30	NV 35	NV 40	NV 50	NV 60	NV 75	NV 90	NV 120	NV 140
Natural Gas G20													
High Fire CO <sub>2</sub> %	6.7	7.3	7.4	7.3	7.8	8.25	7.7	8.7	8.1	8.8	7.4	8.7	8.3
Low Fire CO <sub>2</sub> %	3.7	3.1	3.2	3.7	3.7	3.6	3.6	3.5	3.4	3.6	3.9	4.4	4.6
Propane G31													
High Fire CO <sub>2</sub> %	7.3	7.9	8.5	8.1	9.1	9.2	9.3	9.5	9.1	9.7	8.5	10.1	8.0
Low Fire CO <sub>2</sub> %	4.1	3.8	3.7	4.1	4.1	3.9	4.3	4.0	3.9	4.1	4.5	5.0	4.0

**Fig 7 High/Low and Modulating Head**

- A Low pressure setting screw
- B Valve stem
- C Valve body
- D<sub>1</sub> Locking spring (Modulating Head)
- D<sub>2</sub> Locking spring (Hi/Low Head)
- E Locknut
- F Spring

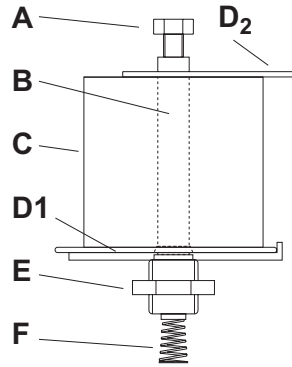

### 6.6.1.2 High/Lo and Modulating Heads

1. Set external controls to ensure that the main burner is off. Remove the side access panel. Connect a pressure gauge to the burner pressure test point on the multifunctional control.
2. Set external controls so as to turn on the main burner and maintain high fire. Compare the measured burner gas pressure to that stated on the data plate. In addition it is advisable to check the gas rate using the gas meter dial pointer. Ensure that no other appliances supplied through the meter are in operation.
3. Repeat 2 above with external controls set to maintain low fire.
4. If it is necessary to adjust the high pressure setting then proceed from step i). If it is only necessary to adjust the low fire pressure setting proceed from step vii).
  - i) Set external controls to turn main burner OFF.
  - ii) Pull back the clip D retaining the actuator coil to its mounting stem and remove the coil.
  - iii) Set external controls to turn main burner ON.
  - iv) Screw adjustment screw A fully clockwise.
  - v) Release the M13 locknut E that secures the actuator stem B into the mfc governor pack and turn the actuator stem to set the HIGH FIRE pressure (clockwise to increase pressure).
  - vi) Tighten the locknut without further turning the actuator stem.
  - vii) Unscrew adjustment screw A to set the LOW FIRE pressure (anti clockwise to decrease pressure).
  - viii) Set external controls to turn burner OFF and replace valve body C onto the valve stem ensuring that it clips into position.
5. Turn off the main burner as in 6.5.1 disconnect the pressure gauge and replace the sealing screw. Turn on the main burner as in 6.5.1 and test for gas soundness around pressure test joint using a leak detection fluid. Replace access panel.

### 6.6.2 Air Heater Controls

1. Close the gas service tap and ensure that the gas valve is heard to close within 1 second and that the lockout light is illuminated. Note that the heater may attempt one reignition before going to lockout. Open the gas service tap and reset the unit from lockout.
2. Check that the room thermostat and all automatic controls are operating satisfactorily.

### 6.7 Handing over the Air Heater

Hand these instructions to the user or purchaser for retention and instruct in the efficient and safe operation of the air heater and associated controls.

Adjust the automatic controls to those values required by the User.

Finally, advise the user or purchaser that, for continued efficient and safe operation of the air heater, it is important that servicing

is carried out annually.

In the event that the premises are not yet occupied turn off the gas and electricity supplies and leave instructional literature adjacent to gas meter.

## 7. Servicing

**WARNING:** Always switch off and disconnect electricity supply and close the gas service valve before carrying out any servicing work or replacement of failed components.

**NOTE:**

If a suspended air heater is to be serviced do not lean ladders against the heater. Ensure that an access tower or equivalent is used.

### 7.1 General

Full maintenance should be undertaken not less than once per year by a qualified person. After any servicing work has been complete or any component replaced the air heater(s) must be fully commissioned and tested for soundness as described in Section 6.

### 7.2 Main Burner Assembly Removal

1. Ensure that the gas service valve is turned OFF and then unscrew the union nut situated immediately down stream of it.
2. Disconnect the spark and rectification leads from the electrodes and remove the electrical plug connections from the top of the gas control valve assembly.
3. If required remove the manifold by removing the four screws securing it to the burner assembly.
4. Remove the two screws that secure the top of the burner assembly to the bulkhead and lift out burner assembly
5. Using a stiff brush, not a wire brush, brush the burners both internally and externally to ensure that they are clean. Examine the injectors and if damaged or deteriorated, replace with new ones of the correct size and marking. If deemed necessary, clean the injectors. Do not broach out with wire.
6. Reassemble the injectors, manifold and burners in reverse order to that above.

### 7.3 Ignition and Rectification Electrodes

1. Inspect the electrodes, making sure that they are in a sound and clean condition. In particular check that the ignition electrode is clean and undamaged. Check that the spark gap is 2.5mm and that the rectification probe is 10 - 12mm forward of the burner.

**Fig 8 Ignition Electrode Spark Gap**

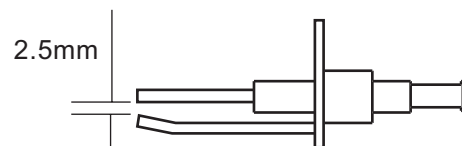

### 7.4 Heat Exchanger

Whilst the main burner assembly is removed from the unit check that the primary sections that the burners fire into are clean.

### 7.5 Main Fan Assembly

#### 7.5.1 NV/F Models

1. Inspect the fan blades to see that they are not damaged and that there is no excessive build up of deposits that could give

rise to an imbalance. Should it be necessary to remove the assembly for cleaning proceed as follows.

2. Slacken the cable gland on the heater casing through which the fan electrical cable passes.
3. Disconnect the fan leads from the electrical terminals on the pcb.
4. Withdraw cable through entry grommet.
5. Remove the fan and motor assembly complete by removing the four hexagon headed bolts that secure the fan to the rear panel.
6. Reassemble in reverse order.

### 7.5.2 Centrifugal Fan/Silencer Section

1. Remove section side panel(s) and inspect the fan blades to see that they are not damaged and that there is no build up of excessive deposits that could give rise to an imbalance. Should it be necessary to remove the assembly for cleaning proceed as follows.
2. Slacken the cable gland on the casing through which the fan electrical cable passes.
3. Disconnect the fan leads from the electrical terminals in the contactor enclosure.
4. Withdraw cable through entry grommet.
5. Remove the complete fan assembly by removing the fixings securing the fan to the base rails.
6. Reassemble in reverse order.

## 7.6 Replacement of Faulty Components

### 7.6.1 Multifunctional Control

1. Remove the burner assembly as previously described in Section 7.2
2. Release the flanged connections at the inlet and outlet of the multifunctional control and remove the multifunctional control.
3. Reconnect the new valve in the reverse order to that above ensuring that the valve is correctly orientated. Renew the sealing 'O' rings if necessary.

### 7.6.2 Burners

1. Remove the burner assembly as previously described in Section 7.2.
2. Remove the end plates of the burner assembly and the central burner support plate.
3. Exchange burners as required and reassemble components in reverse order.
4. Re-commission the appliance as described in Section 6.

### 7.6.3 Electrode Assemblies

1. Disconnect the electrode leads from the pcb terminal as appropriate.
2. Remove the screw securing the electrode assembly to the burner assembly side plate and withdraw the assembly.
3. Fit replacement and reassemble in reverse order. Check that the spark gap is 2.5mm (See Fig. 8) and the rectification electrode is 10 - 12mm forward of the burner.

### 7.6.4 Limit Thermostat

NB. Ensure that the thermostats are set correctly before fitment

Limit Thermostat settings:-

NV 10, 25 - 140	90°C
NV 15 and 20	100°C

NV 35

110°C

1. Remove the screws securing the thermostat phial mounting plate to the inner bulkhead, withdraw assembly and unclip the phial.
2. Remove the electrical connections from the limit thermostat. Remove the securing nut and remove thermostat from the front panel.
3. Fit replacement thermostat in reverse order.

### 7.6.5 High Temperature Thermostat

1. Note their positions and then remove the electrical connections from the high temperature thermostat. Remove the two securing screws and remove thermostat from the bulk head.
2. Fit replacement thermostat in reverse order.

### 7.6.5 Exhaust Fan

1. Remove the four screws securing the flue outlet socket.
2. Disconnect the fan electrical connections from the terminals on the pcb.
3. Remove the two screws at the left hand side of the fan mounting plate that secure it to the exhaust header.
4. Remove fan assembly by pulling forwards and to the left to disengage the retaining lugs.
5. If needed transfer the fan mounting box to the replacement fan.
6. Fit replacement exhaust fan, using new gaskets and silicon sealant as necessary, and reassemble in reverse order.

### 7.6.6 Air Pressure Switch

1. Disconnect electrical connections.
2. Pull off the sensing tube from the air pressure switch.
3. Remove the screws fixing the air pressure switch and remove switch.
4. Fit replacement in reverse order refitting the sensing tube to the negative (- or L) tapping on the pressure switch.

### 7.6.7 Printed Circuit Board (pcb)

1. Disconnect all electrical connections.
2. At each of the five pcb mounting posts squeeze in the retention tag and release the pcb. When all five have been released remove the pcb from its five mounting posts.
3. Fit replacement in reverse order.

### 7.6.8 Centrifugal Fan/Motor

1. Disconnect the electrical connections to the centrifugal fan section.
2. Remove the side panels of the section for access to the fan and motor.
3. Fit replacements as appropriate and reassemble in reverse order.

Note: If a 3ph motor is being replaced ensure that the direction of rotation is correct. If it is not interchange any two of the three phases connected to the motor.



## 8. Connections to External Controls

### Note:

To achieve maximum system efficiency it is recommended that NV units are controlled by an MC100 Fuel Saver unit. Simple room thermostat and room thermostat/timeclock control systems will not enable optimum system efficiency.

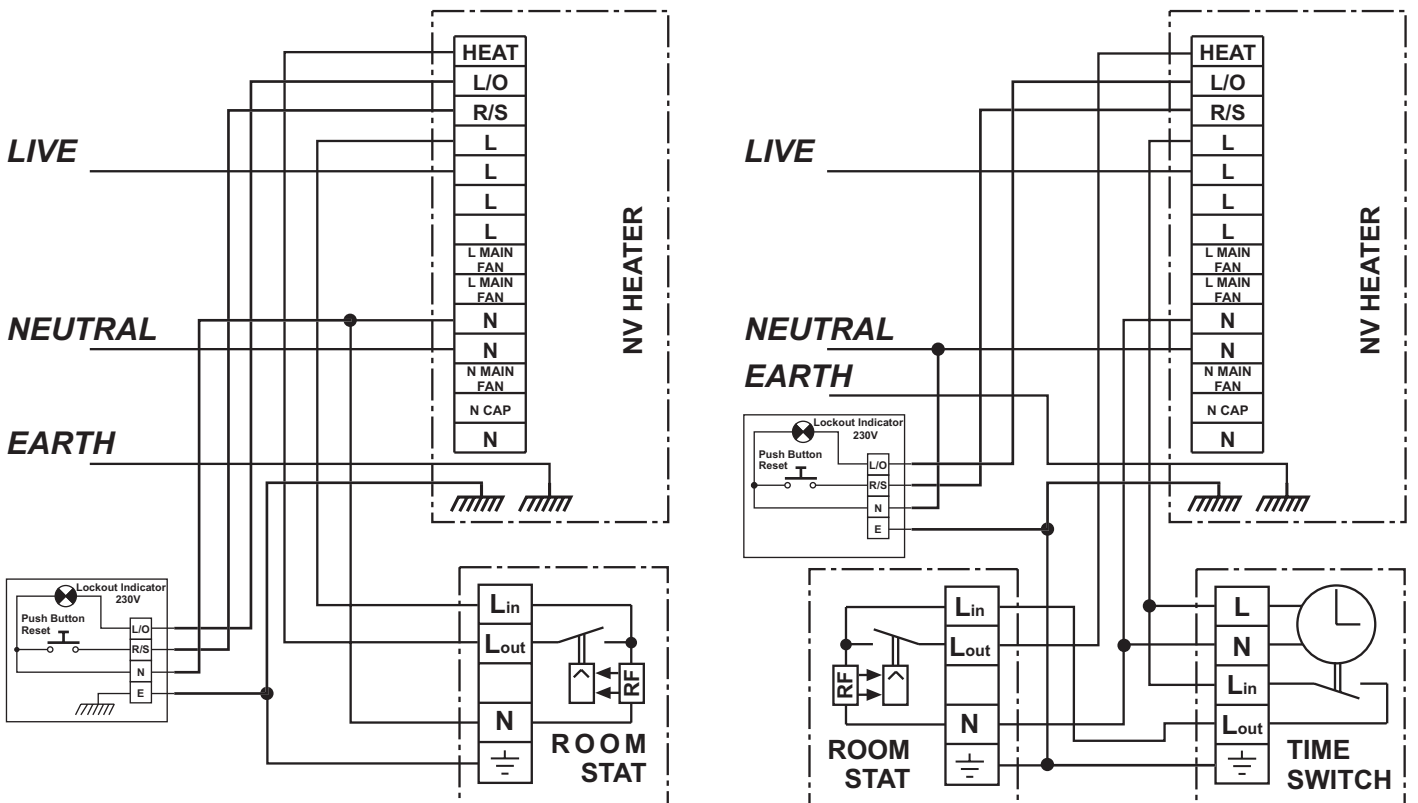
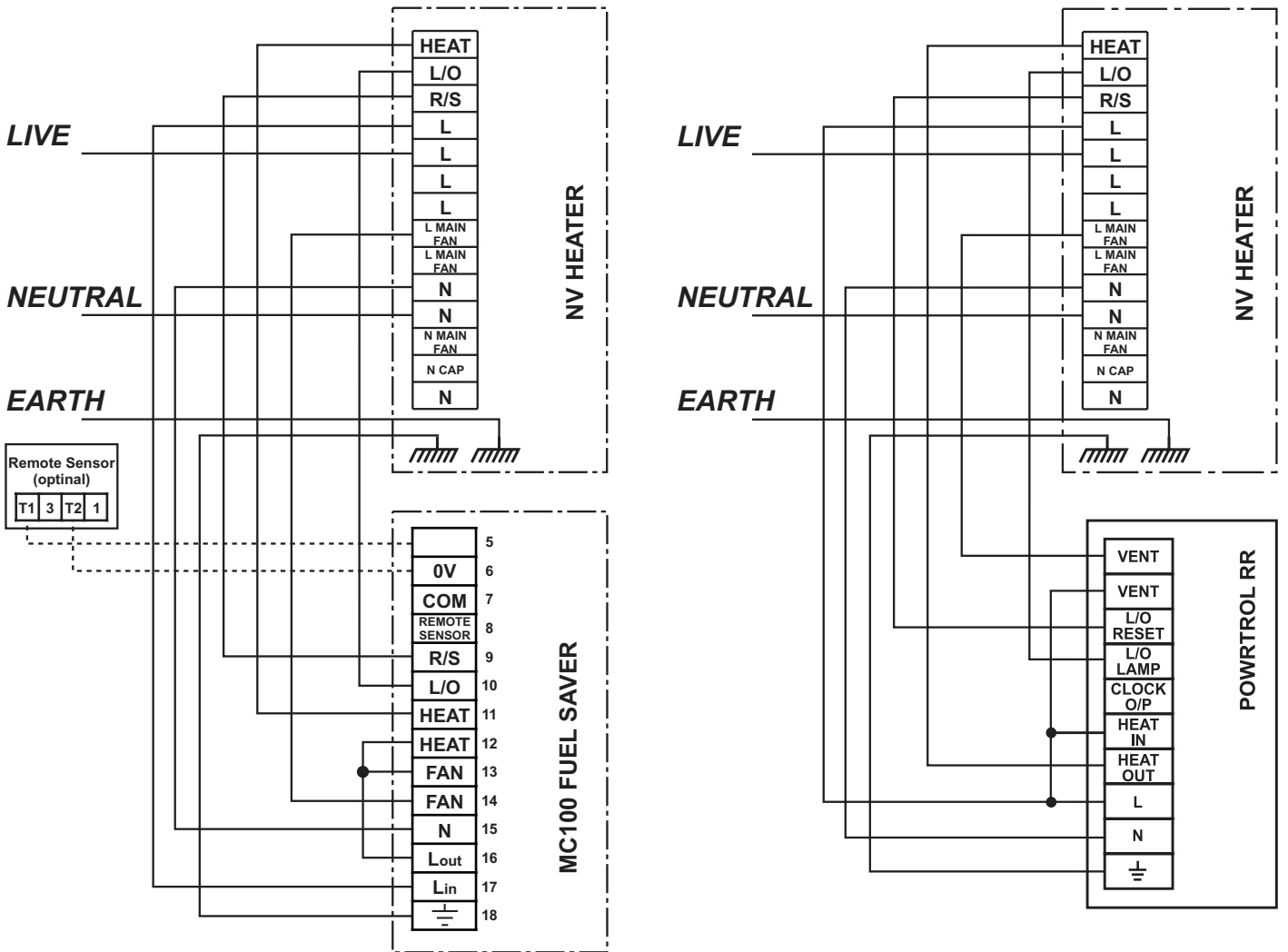











## 9. Fault Finding

<b>Fault</b>	<b>Cause</b>	<b>Action</b>
Internal exhaust fan does not run	Electrical	<ol style="list-style-type: none"> <li>1. Check that there is an electrical supply to the unit and that external control circuit is made.</li> <li>2. Unit at lockout - reset.</li> <li>3. Limit thermostat tripped - reset.</li> <li>4. Faulty PCB.</li> <li>5. Faulty exhaust fan.</li> </ol>
Internal exhaust fan runs but ignition sequence does not start.	Electrical	<ol style="list-style-type: none"> <li>1. Check that air pressure switch is changing over as exhaust fan starts.</li> <li>2. Pressure switch already switched over - check for cause.</li> </ol>
Internal exhaust fan runs, ignition spark is observed but burners do not light.	Electrical	<ol style="list-style-type: none"> <li>1. Ignition spark gap wrong or ignition electrode / lead shorting to earth.</li> <li>2. Faulty PCB.</li> <li>3. Faulty gas control valve.</li> </ol>
	Gas	<ol style="list-style-type: none"> <li>1. Check that gas is available to the unit.</li> </ol>
Burners do not light, main fan runs when there is a call for heat.	Electrical	<ol style="list-style-type: none"> <li>1. Check that high temperature thermostat is not faulty (permanently open circuit).</li> </ol>
Burners light but go out almost immediately.	Electrical	<ol style="list-style-type: none"> <li>1. Rectification electrode position wrong. Electrode/lead damaged - check flame signal.</li> <li>2. Supply polarity reversed</li> </ol>
Burners light but go out after 2 - 3 minutes, main fan does not run.	Electrical	<ol style="list-style-type: none"> <li>1. Main air fan faulty - If Summer/Winter switch fitted check that on Summer setting the fan runs - if it does pcb faulty. Reset limit thermostat when unit has cooled.</li> </ol>
Burners light but go out after some time (controls still calling for heat) and cycle repeats	Electrical	<ol style="list-style-type: none"> <li>1. Reduce air pressure switch setting by turning adjusting screw. Allow burner to fire. Repeat until burner runs constantly.</li> </ol>
Main fan runs continuously	Electrical	<ol style="list-style-type: none"> <li>1. External controls (or Summer/Winter switch if fitted) set to Summer position.</li> <li>2. Faulty PCB.</li> </ol>
Main fan fails to run	Electrical	<ol style="list-style-type: none"> <li>1. Fan motor or capacitor failed - replace.</li> <li>2. Faulty PCB.</li> <li>3. Fan contactor failed - replace (3ph units)</li> </ol>

## 10. Short List of Parts

Only originally specified parts may be fitted as service replacements and all items are available from the Powrmatic Ltd Spares Department. Please refer to Powrmatic Ltd for any parts not shown in the listing.

<b>ITEM</b>	<b>USAGE</b>	<b>PART #</b>
MFC - Honeywell VR4605AB1027 	10-90	145035204
MFC - Honeywell VR425AB1007 	120/140	141378715
Ignition Electrode 	10-75	142423002
Ignition Electrode 	90-140	142423004
Rectification Electrode 	10-140	142423003

Burner - Bray P51 AB 19001 Burner - Bray P51 AB 19002		10-75 90-140	142400240 142400241
Thermostat - Limit - Imit LS1 - 90/110°C		All	142403609
Thermostat - High temperature - Klixon TOD60T13- 60°C		All	143000310
Main PCB		All	142403610/3
Hi/Lo Governor Head - Anglo Nordic MD20003 Modulating Governor Head - Anglo Nordic MD1003/MD Amplifier board - Johnsons PIB-24		10-120 -/HL 10-120 -/MOD 10-120 -/MOD	142466410 142466421 142400304
Exhaust Fan - Sifan WFFB 0223-006		10-50	140210499
Exhaust Fan - Torin 077446 DSA424-215 Exhaust Fan - Torin 077445 DSF180-042		60/75 90-140	140201505 140201506
Dungs Pressure Switch LGW3 A2		All	146522174
Contactora - Danfoss CI-4-5-10		90-140, All -/C	143016131

**HEATING DIVISION**  
**Hort Bridge**  
**Ilminster, Somerset TA19 9PS**  
**Tel: 01460 53535 Fax: 01460 52341**

**BSI Registered Firm**

FM 414  
Ind. & Comm. Air Heaters;  
Air Moving Equipment;  
Flues & Chimneys; Natural  
Smoke & Heat Ventilators;  
Powered Supply & Extract  
Fans & Systems.



ISO 9001