

User's Guide

Profile 40eL - 80eL

About the Boiler This is a Wall Mounted Fan Assisted Balanced Flue Gas Boiler.
This boiler is for use with Natural Gas (G20) only at 20mbar and for use in GB & IE.

- About Safety**
- The Gas Safety (Installation and Use) Regulations 1998.
 - This Appliance Must be installed and serviced by a Competent Person as stated in the above Regulations.
 - If it is known or suspected that a fault exists on the appliance, it must not be used until the fault has been corrected by a competent person.
 - If the appliance is installed in a compartment, do not use it for storage purposes. Do not obstruct any purpose provided ventilation openings.
 - If a gas leak or fault is suspected turn off the appliance and consult your Local Gas Region or Service Engineer.
 - Any warning labels on the appliance must be adhered to.
 - **Consumer Notice:** Please make sure you have carried out the simple checks detailed in these instructions before asking for a Service Engineer to call, as a charge will be made for a service call if it is not due to a manufacturing fault on the appliance.

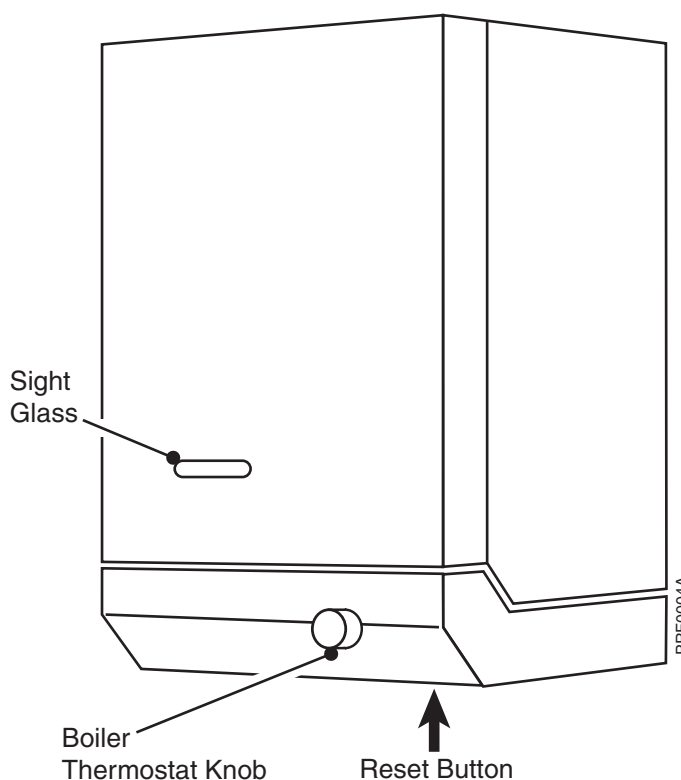

Warning.

Do not interfere with any sealed components on this appliance

It is important that the case of this appliance is not removed for any reason other than for servicing by a qualified service engineer.

The appliance must not be operated without the casing correctly fitted and forming an adequate seal.

Avoid skin contact when the boiler is in operation, as some surfaces may get hot i.e. sight glass, pipework.

SEDBUK Declaration for Profile

Model	Seasonal Efficiency (SEDBUK) (%)
40L	78.0
50L	78.0
60L	78.2
80L	78.4

This value is used in the UK Government's Standard Assessment Procedure (SAP) for energy rating of dwellings. The test data from which it has been calculated have been certified by 0063.



- Potterton is a member of the Benchmark initiative and fully supports the aims of the programme. Benchmark has been introduced to improve the standards of installation and commissioning of central heating systems in the UK and to encourage the regular servicing of all central heating systems to ensure safety and efficiency.

The Benchmark Log Book is an important document and must be kept safely with the boiler. Failure to install and maintain this appliance in accordance with the manufacturer's instructions may invalidate the warranty.

You should ensure that your installer/service engineer completes the relevant sections of the log book when appropriate.

- Samples of the Profile boilers have been examined by Advantica Technologies Limited, a United Kingdom Notified Body. The range is certified to comply with the essential requirements of the Gas Appliance Directive 90/396/EEC, the Low Voltage Directive 72/23/EEC and shows compliance with the Electro Magnetic Compatibility Directive 89/336/EEC, the Boiler Efficiency Directive 92/42/EEC and are therefore permitted to carry the CE Mark.
- **Safety:** The appliance should have the following minimum clearances for Safety and Maintenance, 610 mm at the front, 5 mm each side, 100 mm at the bottom and 50 mm above the case. Flammable materials must not be stored in close proximity to the boiler. Ensure that the flue outlet, outside the house, does not become obstructed, particularly by foliage.

Introduction

The information given will help you obtain the maximum comfort from your boiler with the minimum trouble and cost. Your boiler is fully automatic in operation and requires very little attention apart from setting the thermostat.

Boiler Thermostat

The boiler thermostat enables you to control the temperature of the water as it leaves the boiler and is also used for turning the boiler on and off. The thermostat knob can be set between 'O' (OFF), 1, 2, 3, 4, 5 or Max. The graduations 1 to MAX correspond approximately to a temperature range of 55 °C to 82 °C

During the summer months, when the boiler is only being used to supply stored domestic hot water and there is no independent hot water temperature control, the thermostat can be set to position 1 or 2 which will probably be hot enough for bathing or washing up requirements. For washing clothes a higher setting may be necessary.

In winter weather, when central heating is required, the thermostat knob can be turned up higher but it must be remembered that unless the temperature of the water in the domestic hot water cylinder is independently controlled, the stored hot water could be at a temperature that could scald.

Other Controls

A programmer or clock may have been fitted in your system, together with room and/or cylinder thermostats. Full instructions on the use of these controls should be supplied with them.

To Light

Note: When the boiler is first operated, there may be a slight smell. This will disappear with use.

1. Ensure that the boiler thermostat knob is set at 'O' (fully anti-clockwise).
2. Switch ON the main electricity supply.
3. Ensure the electronic programmer or other time control, if fitted, is in an 'ON' position (refer to the time control literature).
4. Ensure that any room and/or cylinder thermostats are at a high temperature setting.
5. Turn the boiler thermostat on and to the required setting. After a short period, the boiler will light. The main burner can be seen through the sight glass on the front of the boiler.
6. Set the time control and any thermostats to their desired settings.

To Shut Off - Short Periods

Turn the boiler thermostat knob to 'O' (OFF) or switch the programmer to the 'OFF' position. To re-light the boiler, simply turn the boiler thermostat On or switch the programmer 'On'.

To Shut Off - Long Periods

Turn the boiler thermostat knob to 'O' (OFF), isolate the electrical supply at the isolating switch, or pull the electrical plug out of the wall socket.

Important: Read the section on Frost Precaution.

Note: If the system is fitted with a low limit thermostat and protection of the system is required during cold weather, all that is required is for the programmer to be turned to the 'Off' position. This will allow the boiler to cycle if the temperature within the house becomes too low.

Important

Gas and electricity are required to operate your boiler. Its performance will not be affected by normal variation in either supply, but a gas or electricity failure will put the boiler out of operation. It will automatically re-start when the supply is restored provided that the time clock and/or thermostats are in the 'On' position.

Note: In the event of your boiler not working, there are several checks you should carry out before calling in a Service Engineer, as this could save you unnecessary expense.

1. Check that the gas, electricity and water are all turned 'On' at the main supply points.
2. Check that the time control, if fitted, is in an 'On' period.
3. Check that all the thermostats in the system are not on low settings.

Overheat Limit Thermostat

The boiler is fitted with a safety thermostat to protect against overheating of the water. If this thermostat operates the boiler will lockout and fail to re-light, allow the boiler to cool and press the reset button (*Do Not use excessive pressure*). Access to the button is through a hole in the underside of the controls cover, see drawing on front of these instructions. If the control does not reset, leave the boiler for approx. 15 minutes before pressing the reset button again.

If the problem persists, turn off the boiler and consult your Local Installer or Service Engineer.

Note: Interruption of the electrical supply to the boiler may also cause the overheat thermostat to operate.

Having checked these points, run through the lighting procedure once more and if the boiler still fails to light, call in your Service Engineer.

Frost Precautions

If your boiler has to be shut down for several hours or more during very cold weather, it may be in danger of freezing, due to its position, i.e. it may be in an outhouse or part of the pipework may be vulnerable to frost. To avoid freezing, various methods of protection can be used:-

1. Insulation of the boiler and pipework, taking care not to impede any ventilation or air supply.
2. Completely draining the water system if not in use for long periods. On a sealed system, draining and refilling must be carried out by a competent person.

Note: Although the system can be emptied by using the drain off taps installed in the pipework around the system, to empty the boiler, it is necessary to remove the drain screw which is situated on the heat exchanger casting. This should only be done by a competent person.

3. Have a low limit thermostat fitted. If the system is fitted with a low limit thermostat and protection of the system is required during cold weather, all that is required is for the programmer to be turned to the 'Off' position. This will allow the boiler to operate if the temperature within the house becomes too low. The low limit thermostat will not operate if the boiler is completely shut down and the electricity supply turned off. In this instance, the system will have no protection and one of the other methods must be used.
4. Where no frost protection is provided it may be necessary to run the boiler at low thermostat settings at all times when it would normally be shut off.

Cleaning the Outside of the Boiler Casing

The outside of the boiler casing can be wiped when necessary by using a damp cloth to remove finger marks etc. Do not use an abrasive cleaner as this may damage the casing finish.

Care Of Your Boiler and System During the Guarantee Period and Beyond:

1. Registration of Purchase

It is important to register the purchase of your Potterton boiler to ensure you receive prompt and efficient handling in the event your boiler requires attention during the guarantee period.

To register your guarantee simply complete and detach the Registration of Purchase form enclosed with these instructions. It is important to include details of your installer (if known) and to return the completed form to the Potterton Registration Department.

2. During the Guarantee Period

In the event of any problems with your system or the operation of the boiler, you should first **call your installer**. If there is a fault with the boiler under guarantee which your installer is unable to rectify, he/she will call Potterton Service Operations. For 12 months from the date of installation (or 18 months from the date of manufacture, whichever is shorter), Potterton will attend to any manufacturing defect, on the appliance only (not the system or ancillary controls), free of charge for parts and labour, subject to there being no misuse or abuse. This does not effect your statutory rights.

Service visits by Potterton Service Operations outside the terms of the boiler guarantee, will be charged for both parts and labour at our normal rates for chargeable work. During the period of the boiler guarantee, Potterton will only be responsible for the cost of work done by them or on their instructions by their Agent. We cannot accept any liability for expenditure or work done by other parties without our knowledge and/or approval.

3. Safety Check / Routine Maintenance

It is strongly recommended you have your boiler checked annually for safety and for routine maintenance. This should be carried out by a CORGI Registered Installer/Service Agent or Potterton Service Operations to comply with the requirements of the Gas Safety (Installation & Use) Regulations 1998.

4. Boiler Breakdown Insurance

We are pleased to offer you the opportunity to protect your investment once your initial boiler guarantee has expired, by the payment of an annual premium. You can continue with this insurance for the normal life of your boiler and you will find a special 30 day introductory offer for a second year cover together with a card to register your purchase, as part of the "User Pack" supplied with your boiler.

If you have not been handed a Registration Card/additional 2nd Year Breakdown Insurance offer, Please contact the Potterton Registration Department for a copy by telephoning (020) 8944 4972.

General Enquiries

Tel. 08706 060 780

Technical *

Tel. 08706 049 049

Service *

Tel. 08706 096 096

Fax. 01926 410 006

Literature Request

Tel. 08706 060 623

* To aid continuous improvement and staff training, calls to this line may be monitored or recorded.

All descriptions and illustrations provided in this leaflet have been carefully prepared but we reserve the right to make changes and improvements in our products which may affect the accuracy of the information contained in this leaflet. All goods are sold subject to our standard Conditions of Sale which are available on request.

POTTERTON

Baxi Potterton
Brownedge Road, Bamber Bridge
Preston, Lancashire
PR5 6SN

www.potterton.co.uk