

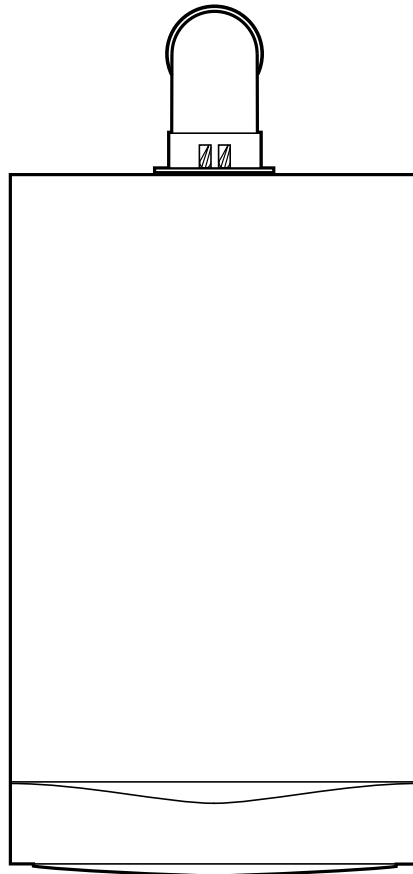

Installation & Service Instructions

Performa System HE



This is a Wall Mounted Powered Flue Condensing Boiler Gas Fired Central Heating Unit.

The boiler meets the requirements of Statutory Instrument “ The Boiler (Efficiency) Regulations 1993 N° 3083” and is deemed to meet the requirements of Directive 92/42/EEC on the energy efficiency requirements for new hot water boilers fired with liquid or gaseous fuels:-

Type test for purpose of Regulation 5 certified by:
Notified Body 0051.

Product/Production certified by:
Notified Body 0051.

For use in GB/IE only.

These instructions include the Benchmark Commissioning Checklist and should be left with the User for safe keeping.

Natural Gas

Potterton Performa System 12 HE

G.C.N° 41 591 24

Potterton Performa System 18 HE

G.C.N° 41 591 25

Potterton Performa System 24 HE

G.C.N° 41 591 26

Potterton Performa System 28 HE

G.C.N° 41 591 27

Building Regulations and the Benchmark Commissioning Checklist

Building Regulations (England & Wales) require notification of the installation of a heating appliance to the relevant Local Authority Building Control Department. From 1 April 2005 this can be achieved via a Competent Persons Self Certification Scheme as an option to notifying the Local Authority directly. Similar arrangements will follow for Scotland and will apply in Northern Ireland from 1 January 2006.

CORGI operate a Self Certification Scheme for gas heating appliances.

These arrangements represent a change from the situation whereby compliance with Building Regulations was accepted as being demonstrated by completion of the Benchmark Logbook (which was then left on site with the customer).

With the introduction of Self Certification Schemes, the Benchmark Logbook is being withdrawn. However, a similar document in the form of a commissioning checklist and service interval record is incorporated at the back of these instructions.

Potterton is a member of the Benchmark initiative and fully supports the aims of the programme. Its aim is to improve the standards of installation and commissioning of central heating systems in the UK and to encourage the regular servicing of all central heating systems to ensure safety and efficiency.

Building Regulations require that installations should comply with manufacturer's instructions. It is therefore important that the commissioning checklist is completed by the installer. The relevant section of Building Regulations only relates to dwellings. Therefore the checklist only applies if the appliance is being installed in a dwelling or some related structure.

The flowchart opposite gives guidance for installers on the process necessary to ensure compliance with Building Regulations.



This product has an energy rating (B) on a scale of A to G.
For more information see www.boilers.org.uk. This is a certification mark.

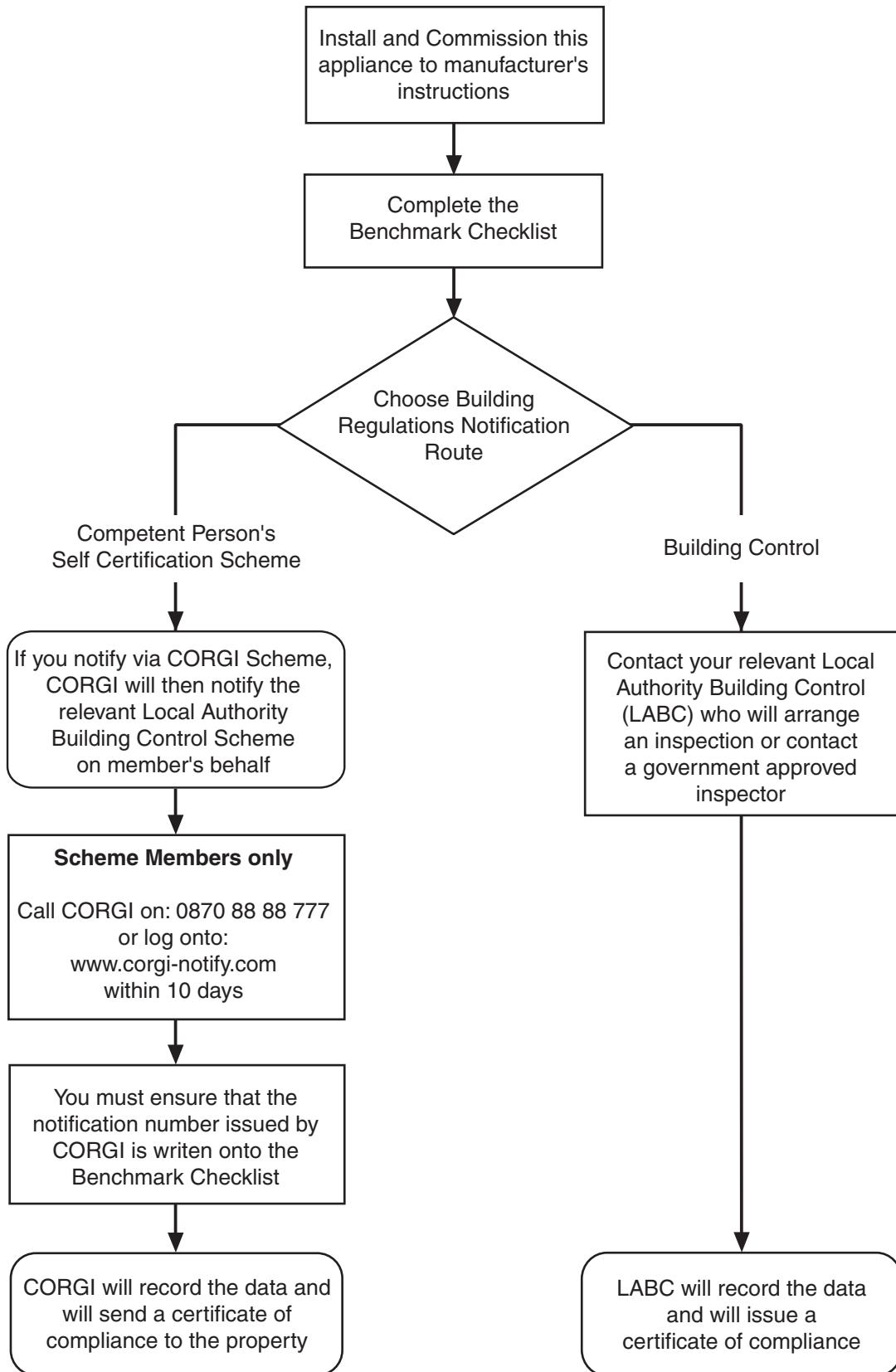

LEGISLATION

IMPORTANT - Installation, Commissioning, Service & Repair

This appliance must be installed in accordance with the manufacturer's instructions and the regulations in force. Read the instructions fully before installing or using the appliance.

In GB, this must be carried out by a competent person as stated in the Gas Safety (Installation & Use) Regulations.

Definition of competence: A person who works for a CORGI registered company and holding current certificates in the relevant ACS modules, is deemed competent.

In IE, this must be carried out by a competent person as stated in I.S. 813 "Domestic Gas Installations".

Lifting - This product should be lifted and handled by two people. Stooping should be avoided and protective equipment worn where necessary. Carrying & lifting equipment should be used as required, e.g. when installing in a loft space.

The addition of anything that may interfere with the normal operation of the appliance without express written permission from the manufacturer or his agent could invalidate the appliance warranty. In GB this could also infringe the Gas Safety (Installation and Use) Regulations.

Warning - Check the information on the data plate is compatible with local supply conditions.

All CORGI registered installers carry a CORGI identification card and have a registration number. You can check your installer is registered by telephoning 0870 4012300 or writing to:-

1 Elmwood,
Chineham Business Park,
Crockford Lane,
Basingstoke. RG24 8WG

or check online at www.corgi-gas-safety.com

Potterton declare that no substances harmful to health are contained in the appliance or used during appliance manufacture.

The appliance is suitable only for installation in GB and IE and should be installed in accordance with the rules in force, and only used in a suitably ventilated location.

In GB, the installation must be carried out by a CORGI Registered Installer. It must be carried out in accordance with the relevant requirements of the:

- Gas Safety (Installation & Use) Regulations.
- The appropriate Building Regulations either The Building Regulations, The Building Regulations (Scotland), Building Regulations (Northern Ireland).
- The Water Fittings Regulations or Water Byelaws in Scotland.
- The Current I.E.E. Wiring Regulations.

Where no specific instructions are given, reference should be made to the relevant British Standard Code of Practice.

In IE, the installation must be carried out by a competent Person and installed in accordance with the current edition of I.S. 813 'Domestic Gas Installations', the current Building Regulations and reference should be made to the current ETCl rules for electrical installation.

All systems must be thoroughly flushed and treated with inhibitor (see section 6.1).

Codes of Practice, most recent version should be used

In GB the following Codes of Practice apply:

Standard	Scope
BS 6891	Gas Installation.
BS 5546	Installation of hot water supplies for domestic purposes.
BS 5449	Forced circulation hot water systems.
BS 6798	Installation of gas fired hot water boilers.
BS 5440 Part 1	Flues.
BS 5440 Part 2	Ventilation.
BS 7074	Expansion vessels and ancillary equipment for sealed water systems.
BS 7593	Treatment of water in domestic hot water central heating systems.

In IE the following Codes of Practice apply:

Standard	Scope
I.S. 813	Domestic Gas Installations.
The following BS standards give valuable additional information;	
BS 5546	Installation of hot water supplies for domestic purposes.
BS 5449	Forced circulation hot water systems.
BS 7074	Expansion vessels and ancillary equipment for sealed water systems.
BS 7593	Treatment of water in domestic hot water central heating systems.

CONTENTS



Section	Page
1.0 Introduction	6
2.0 General Layout	7
3.0 Appliance Operation	8
4.0 Technical Data	9
5.0 Dimensions and Fixings	13
6.0 System Details	14
7.0 Site Requirements	16
8.0 Installation	22
9.0 Commissioning	27
10.0 Completion	29
11.0 Servicing	30
12.0 Changing Components	32
13.0 Electrical	41
14.0 Short Parts List	42
15.0 Fault Finding	43
Benchmark Checklist	46

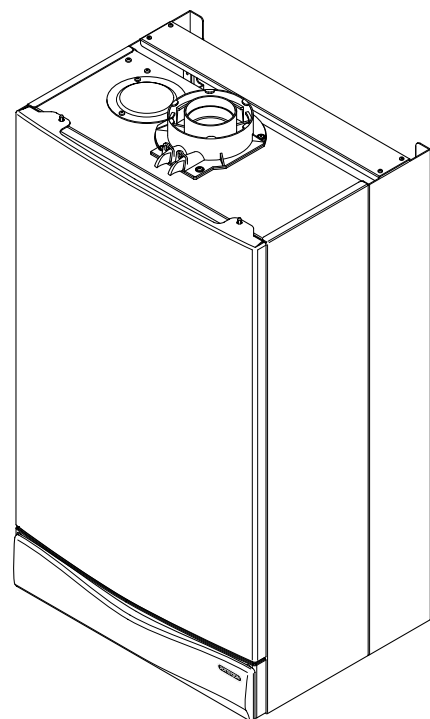

1.0 INTRODUCTION

1.1 Description

1. The Potterton Performa System HE range are fully automatic gas fired wall mounted system boilers. They are room sealed and fan assisted.
2. The boilers are set to give a maximum output of 12.5kW, 18.9kW, 25.2kW or 29.3kW when in condensing mode.
3. They are designed for use on Natural Gas (G20) and can be converted to use Propane.
4. The boiler incorporates a circulating pump and expansion vessel. It is suitable for use only on fully pumped sealed systems.
5. The boiler data badge gives details of the model, serial number and Gas Council number and is situated on the control box. It is visible when the case front panel is removed (Fig. 1).
6. The boiler is intended to be installed in residential / commercial / light industrial E.M.C. environments on a governed meter supply only.
7. The boiler must be installed with one of the purpose designed flues such as the standard horizontal flue kit, part no. 5111073
8. **All systems must be thoroughly flushed and treated with inhibitor (see section 6.1).**

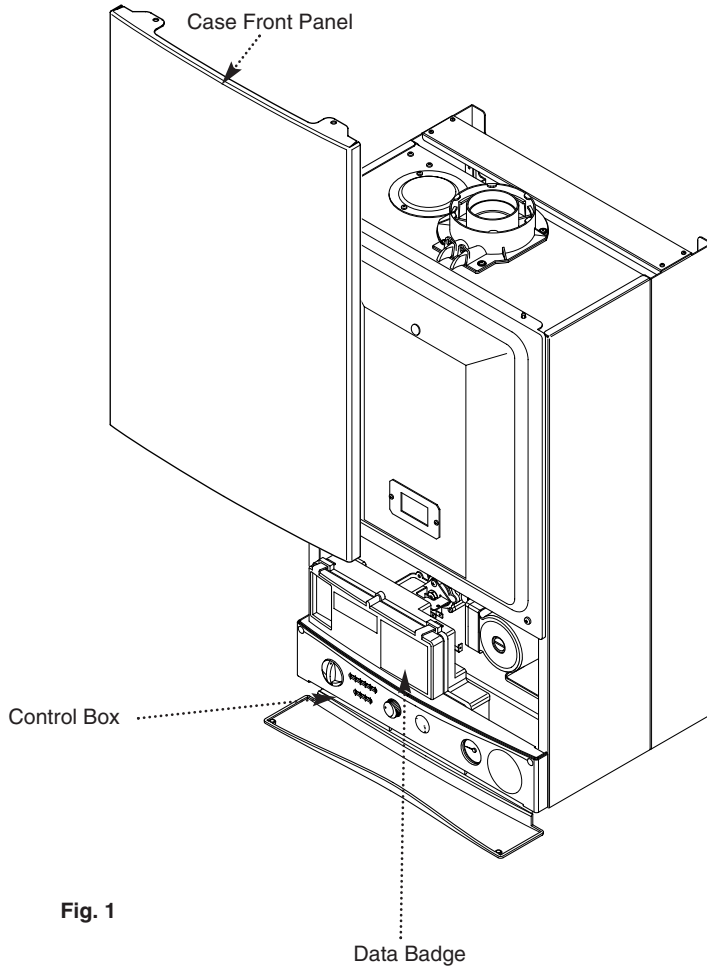

Fig. 1

1.2 Optional Extras

Various flue extensions, bends, vertical flue kits, control accessories etc. are available as optional extras. These are detailed in a separate publication.

NOTE: There are several detail differences between each model. Generally these do not affect the installation or maintenance of the boiler, unless otherwise stated.

2.0 GENERAL LAYOUT



2.1 Layout

1. Air Pressure Switch
2. Expansion Vessel
3. Burner Manifold
4. Automatic Air Vent
5. Circulation Pump
6. Drain Off Point
7. Pressure Relief Valve
8. System Pressure Gauge
9. PCB
10. Control Box
11. Condensate Trap
12. Flame Sensing Electrode
13. Spark Electrode
14. Burner
15. Primary Heat Exchanger
16. Fan Assembly
17. Secondary Heat Exchanger
18. On/Off/Reset Selector Switch
19. Temperature Control
20. Flame Failure or Blocked Condensate Drain
21. Safety Thermostat Activated (Boiler or Flue)
22. Fault on Fan or Flue
23. Fault on Pump or Low System Pressure
24. Fault on Temperature Sensor
25. Fault on Temperature Sensor
26. Power On
27. Boiler On
28. Burner On

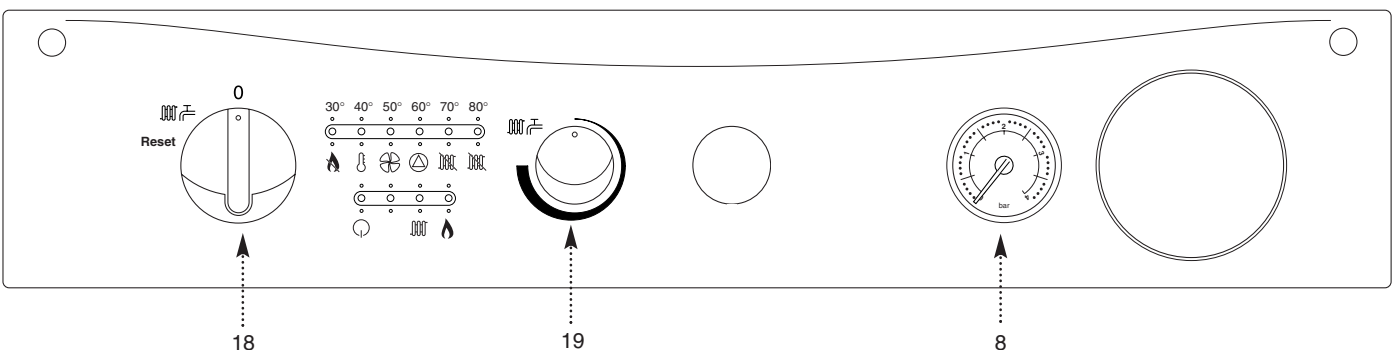
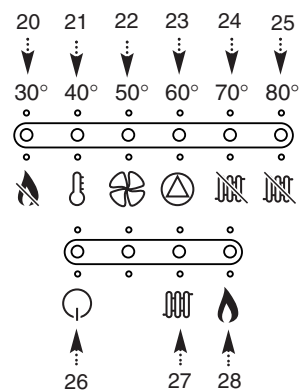
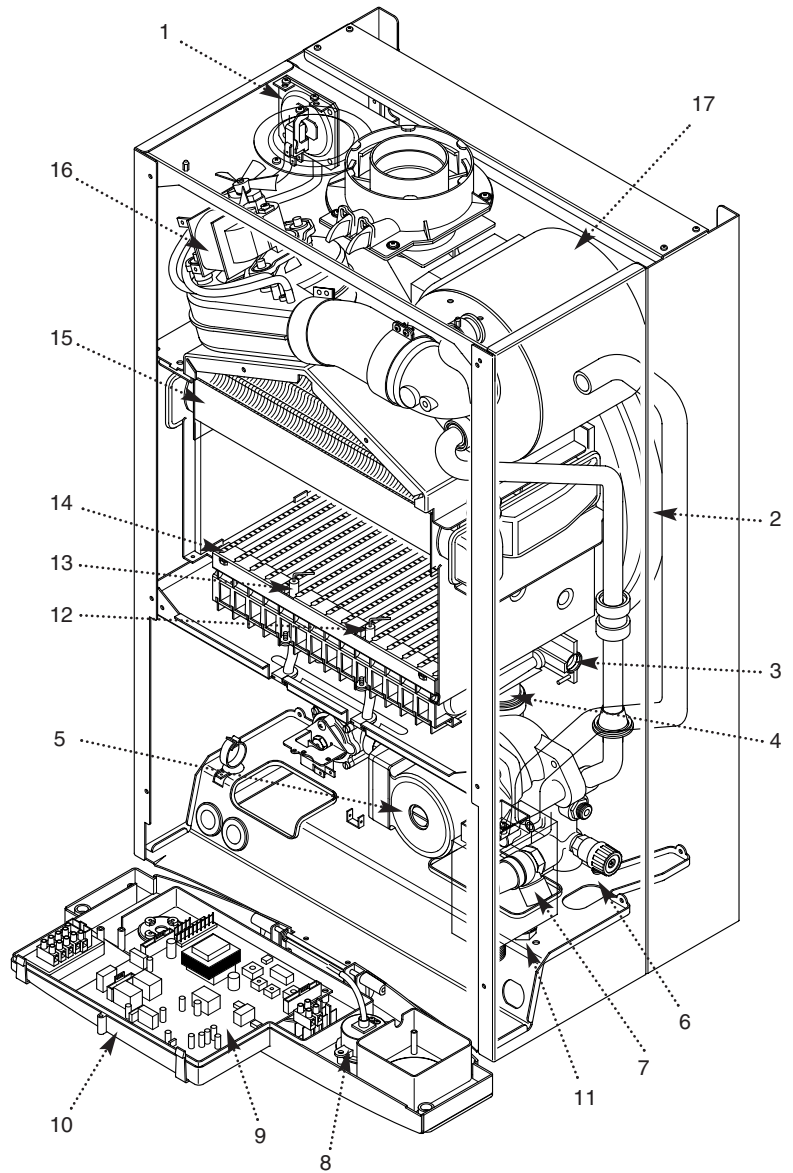

3.0 APPLIANCE OPERATION

3.1 Operating Mode (Fig. 2)

1. With a demand for heating, the pump circulates water through the primary circuit. At a pre-determined flow rate the hydraulic differential pressure switch operates, initiating the ignition sequence.

2. The main burner ignites at low rate, then the gas valve controls the gas rate to maintain the heating temperature measured by the temperature sensor.

3. When the flow temperature exceeds the setting temperature, a 3 minute delay occurs before the burner relights automatically (anti-cycling). The pump continues to run during this period.

4. When the demand is satisfied the burner is extinguished and the pump continues to run for a period of 3 minutes (Pump Overrun).

IMPORTANT: When the selector switch is in the '0' (Off) position the electrical supply to the boiler is isolated. The boiler will not operate.

3.2 Frost Protection Mode

1. The frost protection mode is integral to the appliance and functions when the selector switch (see Section 2.1) is in the ON position (). If the system temperature falls below 5° C then the boiler will fire on its minimum setting until a flow temperature of 30° C is reached. Further protection can be incorporated by using a system frost thermostat.

3.3 Pump Protection

1. With the selector switch (see Section 2.1) in the ON position () the pump will automatically operate for 1 minute in every 24 hours to prevent sticking.

Boiler Primary Circuit

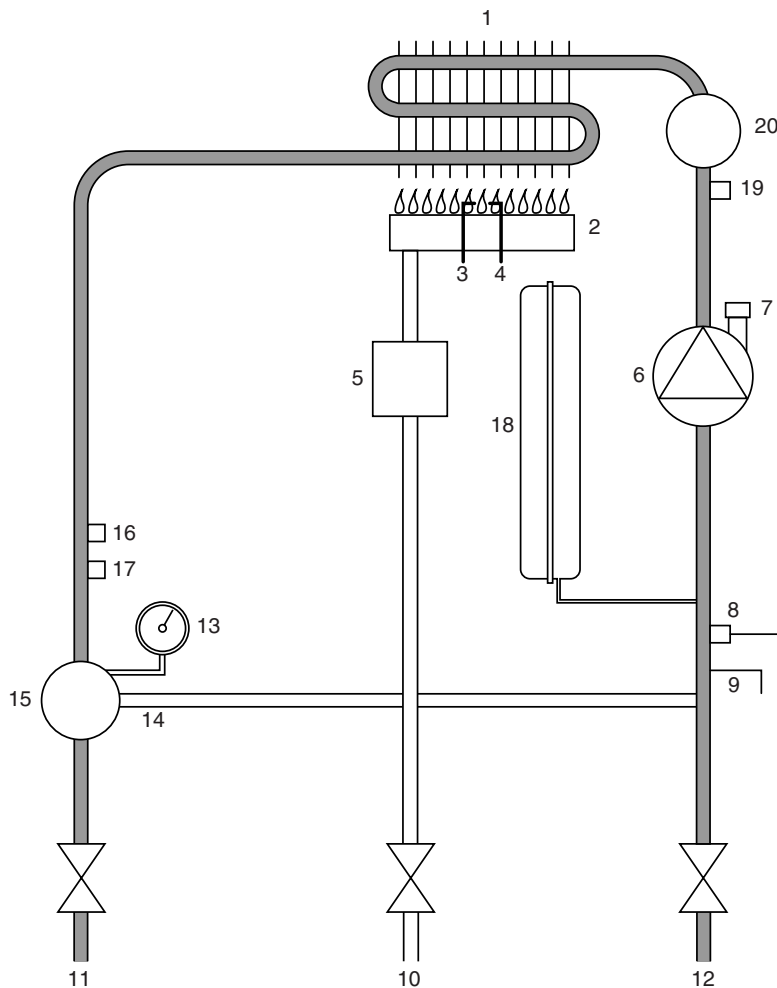

Fig. 2

Key

- 1 Heat Exchanger
- 2 Burner
- 3 Ignition Electrode
- 4 Flame Sensing Electrode
- 5 Gas Valve
- 6 Pump
- 7 Automatic Air Vent
- 8 Pressure Relief Valve
- 9 Boiler Drain Point
- 10 Gas Inlet
- 11 Boiler Flow
- 12 Boiler Return
- 13 Pressure Gauge
- 14 Automatic By-Pass
- 15 Hydraulic Differential Pressure Sensor
- 16 Safety Thermostat
- 17 Temperature Sensor
- 18 Expansion Vessel
- 19 Temperature Sensor
- 20 Secondary Heat Exchanger

4.0 TECHNICAL DATA



4.1 System 12 HE

Appliance Type	C ₁₂	C ₃₂
Appliance Category	CAT II 2H 3P	
Heat Input		
	Max	Min
kW	12.6	7
Heat Output (Non-Condensing)		
	Max	Min
kW	12	6.5
Heat Output (Condensing)		
	Max	Min
kW	12.5	6.7
Max Gas Rate (Natural Gas - G20) (After 10 Mins)		
m ³ /h	1.33	
Burner Pressure (Natural Gas - G20)		
	Max Rate	Min Rate
mbar	5.7 ± 0.5	1.9 ± 0.5
Inlet Pressure (Natural Gas - G20)		
mbar	20	
Burner Injector (Natural Gas - G20) 10 x 1.18mm Diameter		
Electrical Supply 230V~ 50Hz (Appliance must be connected to an earthed supply)		
Power Consumption 140W		
External Fuse Rating 3A		
Internal Fuse Rating Fuse 2A Fast Blow to BS 4265		
Electrical Protection IPX5D		

NO_x Class	3	
Condensate Drain	1" BSP	
Flue Terminal Dimensions		
	Diameter	100mm
	Projection	125mm
Connections copper tails		
Gas Supply	-	22mm
Central Heating Flow	-	22mm
Central Heating Return	-	22mm
Pressure Relief Discharge	-	15mm
Outercase Dimensions		
Casing Height	-	780mm
Overall Height Inc Flue	-	
Elbow	-	965mm
Casing Width	-	450mm
Casing Depth	-	345mm
Clearances		
Above Casing	200 mm Min	
Below Casing	200 mm Min	
Front	450 mm Min (For Servicing)	
Front	5 mm Min (In Operation)	
L.H. Side	5mm Min	
R.H. Side	5mm Min (In Operation) 20mm Min (See Note*)	
*NOTE: The boiler can be operated with a clearance of 5mm at the right. This is also sufficient for routine maintenance. However a clearance of 20mm is required if it is necessary to remove the secondary heat exchanger. This should be considered when siting the appliance and in the event of any subsequent alterations in the area of installation		
Weights		
		kg
Packaged Boiler Carton		48.5
Installation Lift Weight		38

Central Heating Primary Circuit Pressures

Safety Discharge	bar	3
Max Operating		2.5
Min Operating		0.5
Recommend Operating		1-2

Pump

Available Head See graph below

Expansion Vessel - (For Central Heating only. Integral with appliance)

Min Pre-charge Pressure	bar	0.5
-------------------------	-----	-----

Max Capacity of CH System	litre	125
---------------------------	-------	-----

Primary Water Content of Boiler (unpressurised)		1.2
---	--	-----

Temperatures

Flow Temp (adjustable)
35°C to 85°C max (± 5°C)

SEDBUK Declaration For Performa System 12 HE

The seasonal efficiency (SEDBUK) is 86.8% (86.6% LPG) Band B

This value is used in the UK Government's Standard Assessment Procedure (SAP) for energy rating of dwellings. The test data from which it has been calculated have been certified by 0051.

LPG Propane - G31		
Burner Injector 0.69mm diameter		
Burner Pressure	Max Rate	Min Rate
Propane	mbar	23.4 ± 0.5
		7.4 ± 0.2
Inlet Pressure	mbar	
	37	

Pump - Available Head

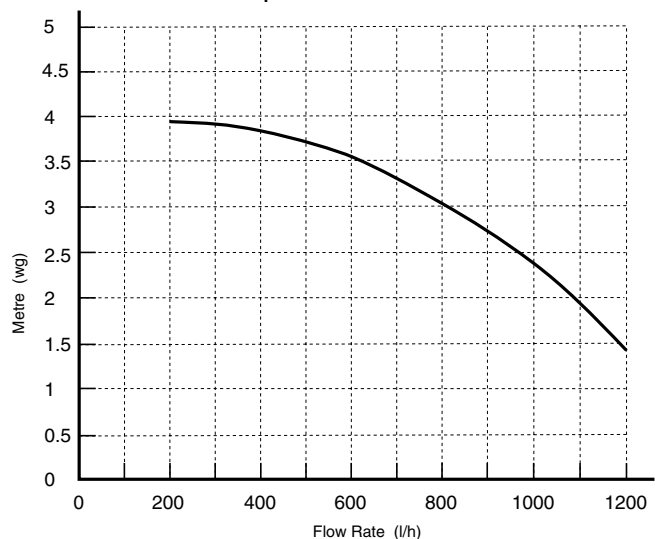

4.0 TECHNICAL DATA

4.2 System 18 HE

Appliance Type	C ₁₂	C ₃₂
Appliance Category	CAT II 2H 3P	
Heat Input		
	Max	Min
kW	18.7	10.6
Heat Output (Non-Condensing)		
	Max	Min
kW	18	9.9
Heat Output (Condensing)		
	Max	Min
kW	18.9	10.2
Max Gas Rate (Natural Gas - G20) (After 10 Mins)		
m ³ /h	1.98	
Burner Pressure (Natural Gas - G20)		
	Max Rate	Min Rate
mbar	8.6 ± 0.5	3 ± 0.5
Inlet Pressure (Natural Gas - G20)		
mbar	20	
Burner Injector (Natural Gas - G20) 12 x 1.18mm Diameter		
Electrical Supply 230V~ 50Hz (Appliance must be connected to an earthed supply)		
Power Consumption 140W		
External Fuse Rating 3A		
Internal Fuse Rating Fuse 2A Fast Blow to BS 4265		
Electrical Protection IPX5D		

NO_x Class	3	
Condensate Drain	1" BSP	
Flue Terminal Dimensions		
	Diameter	100mm
	Projection	125mm
Connections copper tails		
Gas Supply	-	22mm
Central Heating Flow	-	22mm
Central Heating Return	-	22mm
Pressure Relief Discharge	-	15mm
Outercase Dimensions		
Casing Height	-	780mm
Overall Height Inc Flue	-	
Elbow	-	965mm
Casing Width	-	450mm
Casing Depth	-	345mm
Clearances		
Above Casing	200 mm Min	
Below Casing	200 mm Min	
Front	450 mm Min (For Servicing)	
Front	5 mm Min (In Operation)	
L.H. Side	5mm Min	
R.H. Side	5mm Min (In Operation) 20mm Min (See Note*)	
<p>*NOTE: The boiler can be operated with a clearance of 5mm at the right. This is also sufficient for routine maintenance. However a clearance of 20mm is required if it is necessary to remove the secondary heat exchanger. This should be considered when siting the appliance and in the event of any subsequent alterations in the area of installation</p>		
Weights		
Packaged Boiler Carton	49 kg	
Installation Lift Weight	38.5 kg	

Central Heating Primary Circuit Pressures

	bar
Safety Discharge	3
Max Operating	2.5
Min Operating	0.5
Recommend Operating	1-2

Pump

Available Head See graph below

Expansion Vessel - (For Central Heating only. Integral with appliance)

	bar
Min Pre-charge Pressure	0.5

	litre
Max Capacity of CH System	125

Primary Water Content of Boiler (unpressurised)	1.2
---	-----

Temperatures

Flow Temp (adjustable)
35°C to 85°C max (± 5°C)

SEDBUK Declaration For Performa System 18 HE

The seasonal efficiency (SEDBUK) is 87.4% (87.3% LPG)
Band B

This value is used in the UK Government's Standard Assessment Procedure (SAP) for energy rating of dwellings. The test data from which it has been calculated have been certified by 0051.

LPG Propane - G31

Burner Injector 0.77mm diameter

Burner Pressure	Max Rate	Min Rate
Propane	mbar 20 ± 0.5	6.6 ± 0.2

Inlet Pressure	
mbar	37

Pump - Available Head

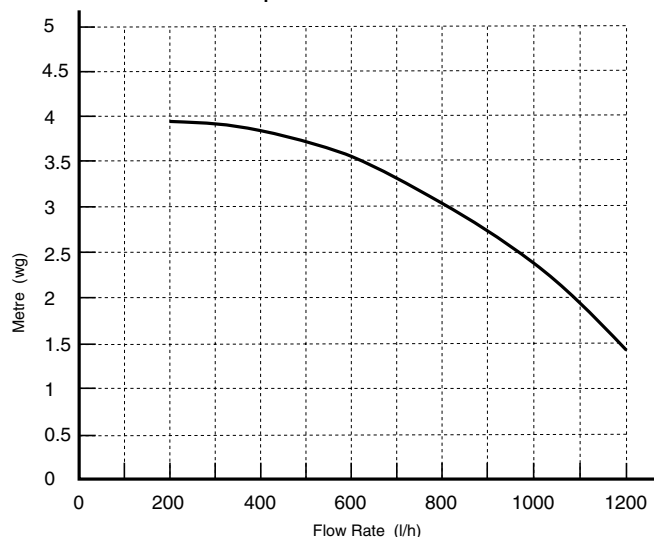

4.0 TECHNICAL DATA



4.3 System 24 HE

Appliance Type	C ₁₂	C ₃₂
Appliance Category	CAT II 2H 3P	
Heat Input		
	Max	Min
kW	24.8	10.6
Heat Output (Non-Condensing)		
	Max	Min
kW	24	9.8
Heat Output (Condensing)		
	Max	Min
kW	25.2	10.1
Max Gas Rate (Natural Gas - G20) (After 10 Mins)		
m ³ /h	2.62	
Burner Pressure (Natural Gas - G20)		
	Max Rate	Min Rate
mbar	10.2 ± 0.5	2 ± 0.5
Inlet Pressure (Natural Gas - G20)		
mbar	20	
Burner Injector (Natural Gas - G20) 15 x 1.18mm Diameter		
Electrical Supply 230V~ 50Hz (Appliance must be connected to an earthed supply)		
Power Consumption 170W		
External Fuse Rating 3A		
Internal Fuse Rating Fuse 2A Fast Blow to BS 4265		
Electrical Protection IPX5D		

NO_x Class	3	
Condensate Drain	1" BSP	
Flue Terminal Dimensions		
	Diameter	100mm
	Projection	125mm
Connections copper tails		
Gas Supply	-	22mm
Central Heating Flow	-	22mm
Central Heating Return	-	22mm
Pressure Relief Discharge	-	15mm
Outercase Dimensions		
Casing Height	-	780mm
Overall Height Inc Flue	-	
Elbow	-	965mm
Casing Width	-	450mm
Casing Depth	-	345mm
Clearances		
Above Casing	200 mm Min	
Below Casing	200 mm Min	
Front	450 mm Min (For Servicing)	
Front	5 mm Min (In Operation)	
L.H. Side	5mm Min	
R.H. Side	5mm Min (In Operation) 20mm Min (See Note*)	
*NOTE: The boiler can be operated with a clearance of 5mm at the right. This is also sufficient for routine maintenance. However a clearance of 20mm is required if it is necessary to remove the secondary heat exchanger. This should be considered when siting the appliance and in the event of any subsequent alterations in the area of installation		
Weights		
		kg
Packaged Boiler Carton		51
Installation Lift Weight		40.5

Central Heating Primary Circuit Pressures

Safety Discharge	3	bar
Max Operating	2.5	
Min Operating	0.5	
Recommend Operating	1-2	

Pump

Available Head See graph below

Expansion Vessel - (For Central Heating only. Integral with appliance)

Min Pre-charge Pressure	0.5	bar
-------------------------	-----	-----

Max Capacity of CH System	125	litre
---------------------------	-----	-------

Primary Water Content of Boiler (unpressurised)	1.2	
---	-----	--

Temperatures

Flow Temp (adjustable)
35°C to 85°C max (± 5°C)

SEDBUK Declaration For Performa System 24 HE

The seasonal efficiency (SEDBUK) is 87.4% (87.2% LPG)
Band B

This value is used in the UK Government's Standard Assessment Procedure (SAP) for energy rating of dwellings. The test data from which it has been calculated have been certified by 0051.

LPG Propane - G31		
Burner Injector 0.77mm diameter		
Burner Pressure	Max Rate	Min Rate
Propane	mbar 21.8 ± 0.5	4.4 ± 0.2
Inlet Pressure		
mbar	37	

Pump - Available Head

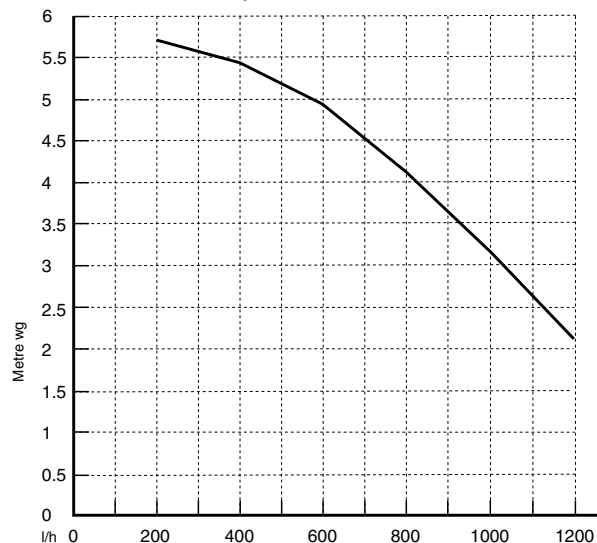

4.0 TECHNICAL DATA

4.4 System 28 HE

Appliance Type	C ₁₂	C ₃₂
Appliance Category	CAT II 2H 3P	
Heat Input		
	Max	Min
kW	28.9	11.9
Heat Output (Non-Condensing)		
	Max	Min
kW	28	11
Heat Output (Condensing)		
	Max	Min
kW	29.3	11.3
Max Gas Rate (Natural Gas - G20) (After 10 Mins)		
m ³ /h	3.06	
Burner Pressure (Natural Gas - G20)		
	Max Rate	Min Rate
mbar	10.9 ± 0.5	2.1 ± 0.5
Inlet Pressure (Natural Gas - G20)		
mbar	20	
Burner Injector (Natural Gas - G20) 15 x 1.25mm Diameter		
Electrical Supply 230V~ 50Hz (Appliance must be connected to an earthed supply)		
Power Consumption 180W		
External Fuse Rating 3A		
Internal Fuse Rating Fuse 2A Fast Blow to BS 4265		
Electrical Protection IPX5D		

NO_x Class	3	
Condensate Drain	1" BSP	
Flue Terminal Dimensions		
Diameter	100mm	
Projection	125mm	
Connections copper tails		
Gas Supply	- 22mm	
Central Heating Flow	- 22mm	
Central Heating Return	- 22mm	
Pressure Relief Discharge	- 15mm	
Outercase Dimensions		
Casing Height	- 780mm	
Overall Height Inc Flue		
Elbow	- 965mm	
Casing Width	- 450mm	
Casing Depth	- 345mm	
Clearances		
Above Casing	200 mm Min	
Below Casing	200 mm Min	
Front	450 mm Min (For Servicing)	
Front	5 mm Min (In Operation)	
L.H. Side	5mm Min	
R.H. Side	5mm Min (In Operation) 20mm Min (See Note*)	
<p>*NOTE: The boiler can be operated with a clearance of 5mm at the right. This is also sufficient for routine maintenance. However a clearance of 20mm is required if it is necessary to remove the secondary heat exchanger. This should be considered when siting the appliance and in the event of any subsequent alterations in the area of installation</p>		
Weights		
Packaged Boiler Carton	51 kg	
Installation Lift Weight	40.5 kg	

Central Heating Primary Circuit Pressures	
	bar
Safety Discharge	3
Max Operating	2.5
Min Operating	0.5
Recommend Operating	1-2
Pump	
Available Head	See graph below
Expansion Vessel - (For Central Heating only. Integral with appliance)	
	bar
Min Pre-charge Pressure	0.5
	litre
Max Capacity of CH System	125
Primary Water Content of Boiler (unpressurised)	
	1.2
Temperatures	
Flow Temp (adjustable)	35°C to 85°C max (± 5°C)

SEDBUK Declaration For Performa System 28 HE

The seasonal efficiency (SEDBUK) is 87.3% (87.2% LPG)
Band B

This value is used in the UK Government's Standard Assessment Procedure (SAP) for energy rating of dwellings. The test data from which it has been calculated have been certified by 0051.

LPG Propane - G31		
Burner Injector 0.77mm diameter		
Burner Pressure	Max Rate	Min Rate
Propane	mbar 29.4 ± 0.5	5.2 ± 0.2
Inlet Pressure		
mbar	37	

Pump - Available Head

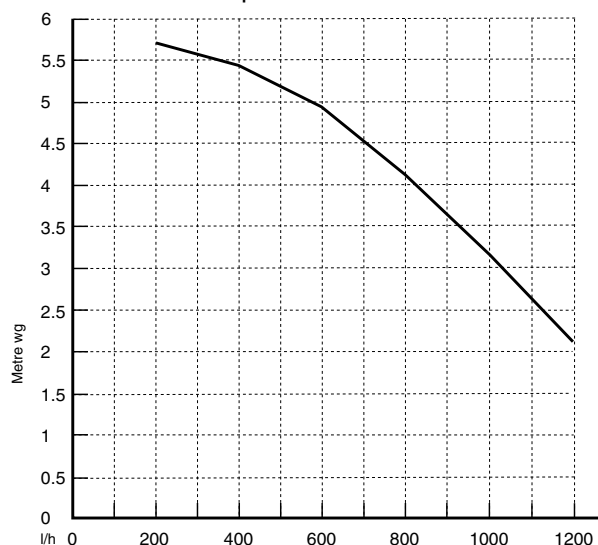

5.0 DIMENSIONS AND FIXINGS

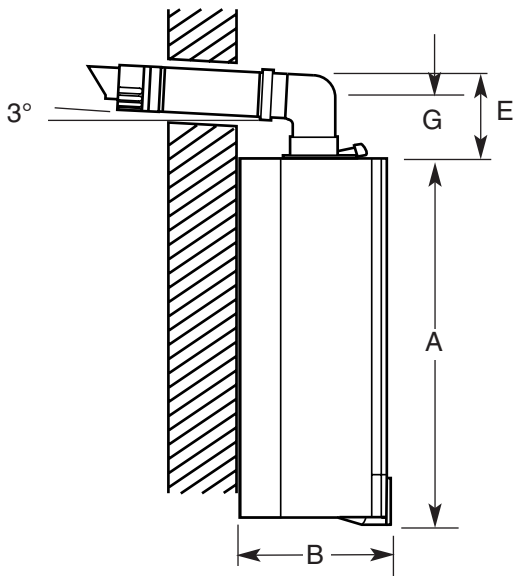

Dimensions	
A	780mm
B	345mm
C	450mm
D	107mm Ø Min.
E	185mm
F	190mm
G	131mm

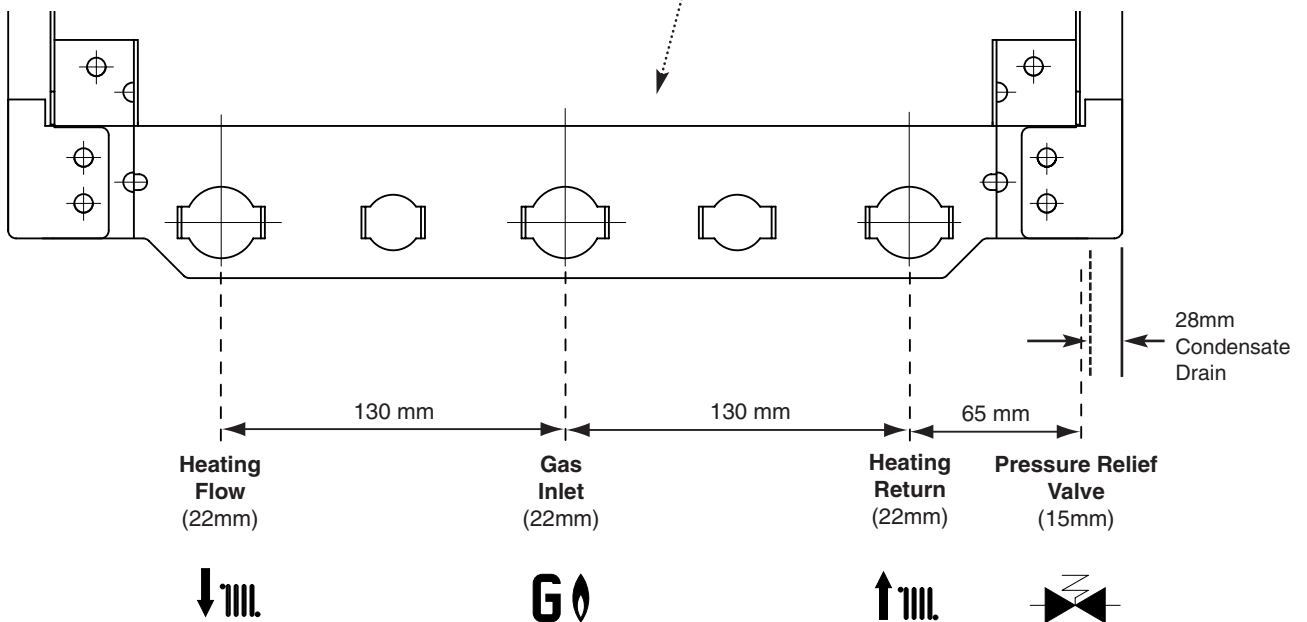
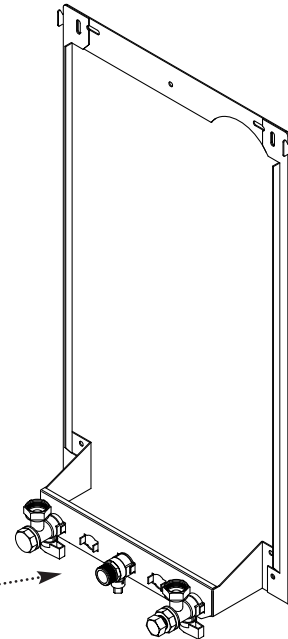
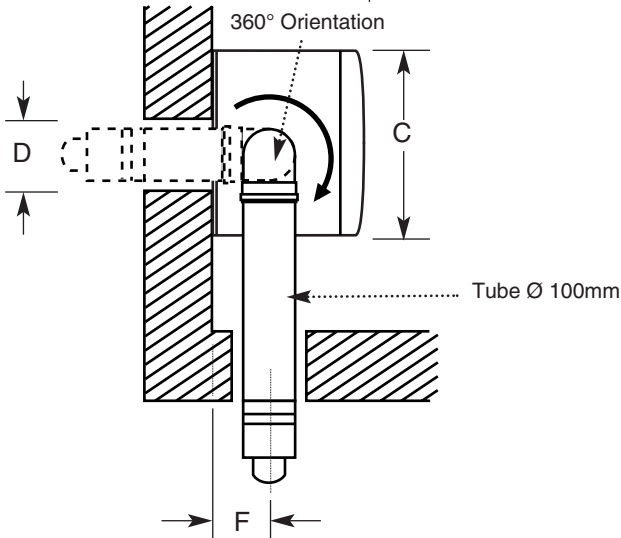

6.0 SYSTEM DETAILS

6.1 Central Heating Circuit

1. The appliance is suitable for fully pumped SEALED SYSTEMS ONLY.

Treatment of Water Circulating Systems

- All recirculatory water systems will be subject to corrosion unless an appropriate water treatment is applied. This means that the efficiency of the system will deteriorate as corrosion sludge accumulates within the system, risking damage to pump and valves, boiler noise and circulation problems.
- When upgrading existing systems that exhibit evidence of sludging, it is advisable to clean the system prior to treatment in order to remove any sludge and reduce the likelihood of these deposits damaging new components.
- When fitting new systems flux will be evident within the system, which can lead to damage of system components.
- All systems must be thoroughly drained and flushed out. The recommended flushing and cleansing agents are Betz-Dearborn Sentinel X300 or X400 and Fernox Superfloc Universal Cleanser which should be used following the flushing agent manufacturer's instructions.
- System additives - corrosion inhibitors and flushing agents/descalers should be suitable for aluminium and comply to BS7593 requirements. The only system additives recommended are Betz-Dearborn Sentinel X100 and Fernox-Copal which should be used following the inhibitor manufacturer's instructions.

Failure to flush and add inhibitor to the system will invalidate the appliance warranty.

- It is important to check the inhibitor concentration after installation, system modification and at every service in accordance with the manufacturer's instructions. (Test kits are available from inhibitor stockists.)
- For information or advice regarding any of the above contact Technical Enquiries.

6.2 Bypass

1. The boiler is fitted with an automatic integral bypass.

6.3 System Control

1. For optimum operating conditions, the heating system into which the boiler is installed should include a control system.
2. Such a system will comprise of a timer control and separate room or cylinder thermostats as appropriate.
3. The boiler should be controlled so that it operates on demand only.
4. Operation of the system under control of the boiler thermostat & TRV's only does not produce the best results.

6.0 SYSTEM DETAILS

6.4 System Filling and Pressurising

1. A filling point connection on the central heating return pipework must be provided to facilitate initial filling and pressurising and also any subsequent water loss replacement/refilling.
2. The filling method adopted must be in accordance with all relevant water supply regulations and use approved equipment.
3. Your attention is drawn to: for GB: guidance G24.2 and recommendation R24.2 of the Water Regulations Guide.
for IE: the current edition of I.S. 813 "Domestic Gas Installations".

4. The sealed primary circuits may be filled or replenished by means of a temporary connection between the circuit and a supply pipe provided a 'Listed' double check valve or some other no less effective backflow prevention device is permanently connected at the inlet to the circuit and the temporary connection is removed after use.

6.5 Expansion Vessel

1. The appliance expansion vessel is pre-charged to 0.5 bar. The vessel is suitable for correct operation for system capacities up to 125 litres. For greater system capacities an additional expansion vessel must be fitted. for GB refer to BS 7074 Pt 1. For IE, the current edition of I.S. 813 "Domestic Gas Installations".

6.6 Pressure Relief Valve (Fig. 4)

1. The pressure relief valve is set at 3 bar, therefore all pipework, fittings, etc. should be suitable for pressures in excess of 3 bar.
2. The pressure relief discharge pipe should be not less than 15mm dia, run continuously downward, and discharge outside the building, preferably over a drain. It should be routed in such a manner that no hazard occurs to occupants or causes damage to wiring or electrical components. The end of the pipe should terminate facing down and towards the wall.
3. The discharge must not be above a window, entrance or other public access. Consideration must be given to the possibility that boiling water/steam could discharge from the pipe.

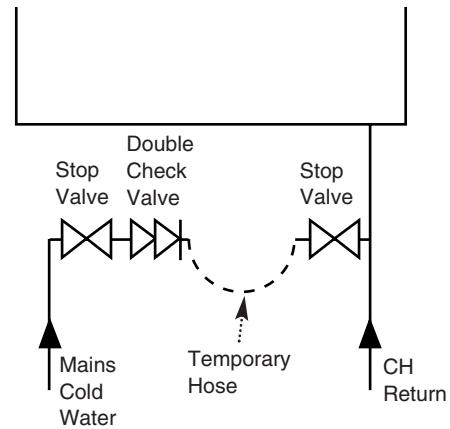

Fig. 3

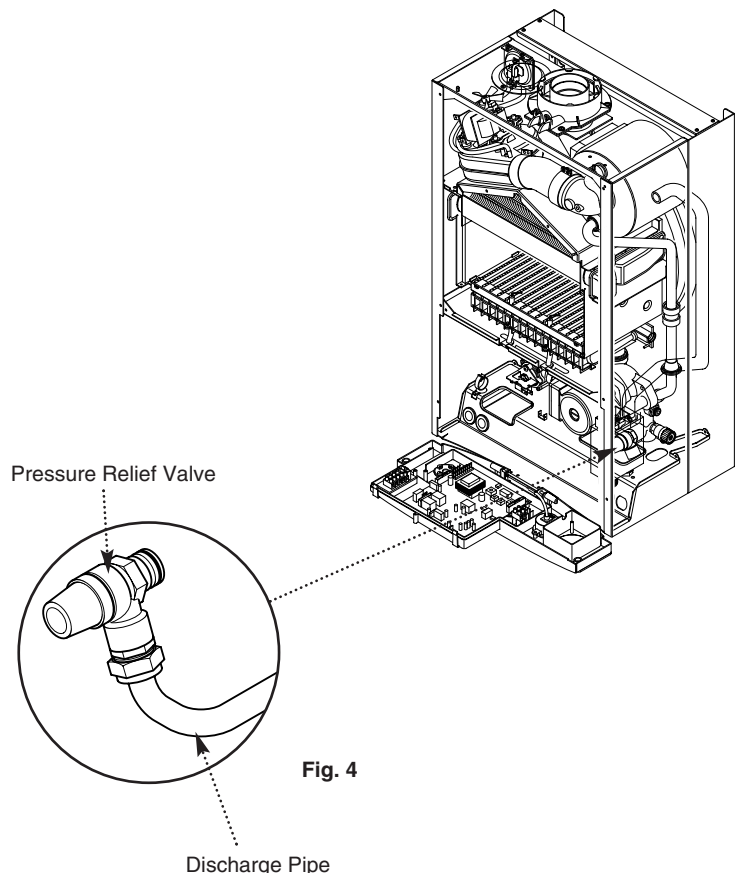

Fig. 4

7.0 SITE REQUIREMENTS

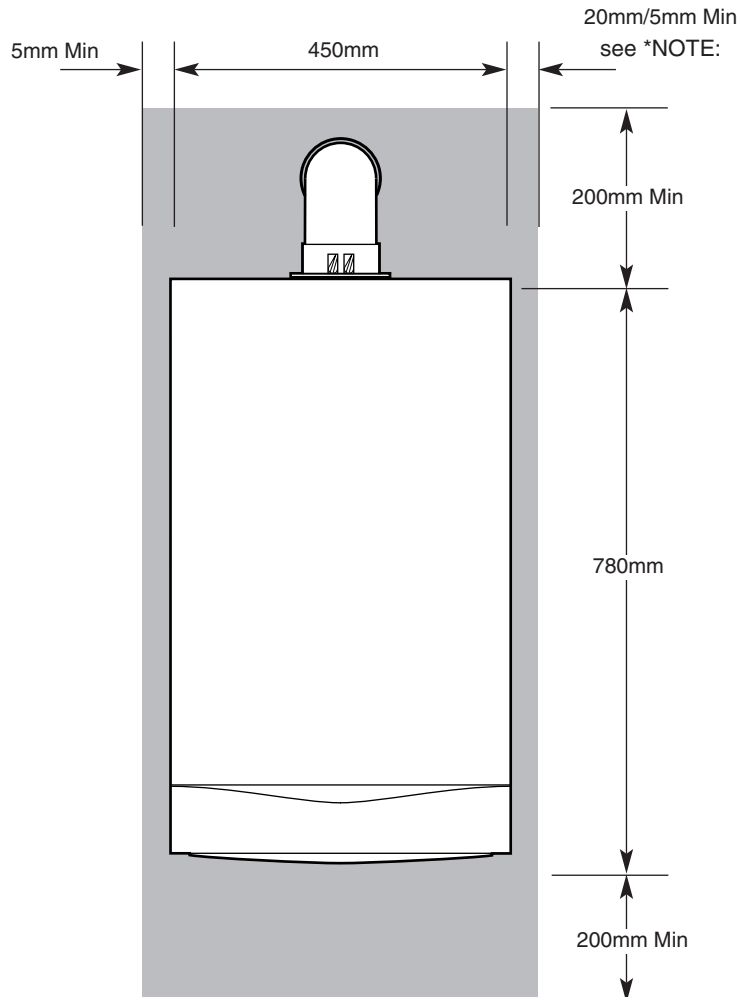

Fig. 5

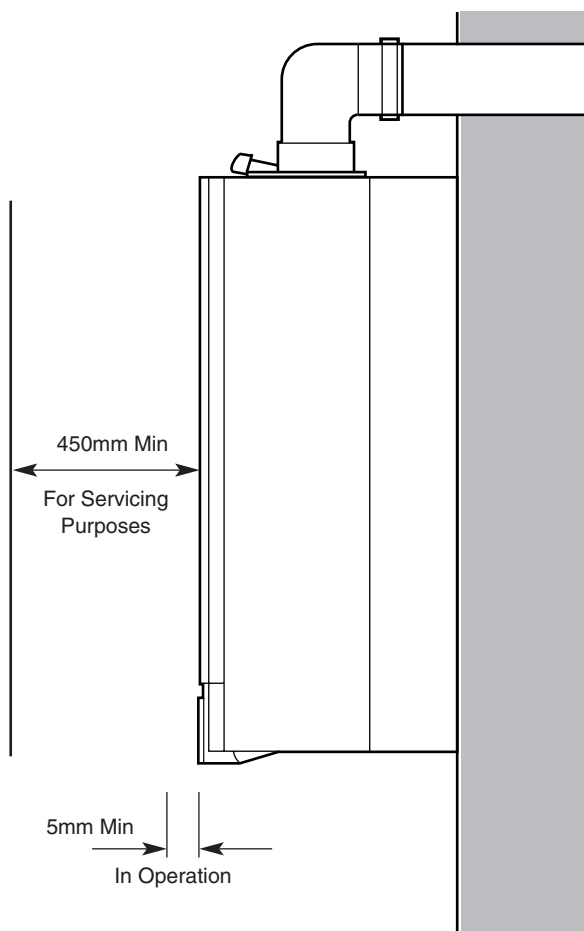

Fig. 6

7.1 Location

1. The boiler may be fitted to any suitable wall with the flue passing through an outside wall or roof and discharging to atmosphere in a position permitting satisfactory removal of combustion products and providing an adequate air supply. The boiler should be fitted within the building unless otherwise protected by a suitable enclosure i.e. garage or outhouse. (The boiler may be fitted inside a cupboard-see Section 7.3).

2. If the boiler is sited in an unheated enclosure then it is recommended to leave the On/Off/Reset Selector Switch in the On Position.

3. If the boiler is fitted in a room containing a bath or shower reference must be made to the relevant requirements.

In GB this is the current I.E.E. Wiring Regulations and Building Regulations.

In IE reference should be made to the current edition of I.S. 813 "Domestic Gas Installations" and the current ETCI rules.

4. If the boiler is to be fitted into a building of timber frame construction then reference must be made to the current edition of Institute of Gas Engineers Publication IGE/UP/7 (Gas Installations in Timber Framed Housing).

7.2 Clearances (Figs. 5 & 6)

1. A flat vertical area is required for the installation of the boiler.

2. These dimensions include the necessary clearances around the boiler for case removal, spanner access and air movement. Additional clearances may be required for the passage of pipes around local obstructions such as joists running parallel to the front face of the boiler.

***NOTE:** The boiler can be operated with a clearance of 5mm at the right. This is also sufficient for routine maintenance. However a clearance of 20mm is required if it is necessary to remove the secondary heat exchanger. This should be considered when siting the appliance and in the event of any subsequent alterations in the area of installation.

7.0 SITE REQUIREMENT

7.3 Ventilation of Compartments

1. Where the appliance is installed in a cupboard or compartment, no air vents are required.

2. BS 5440: Part 2 refers to room sealed appliances installed in compartments. The appliance will run sufficiently cool without ventilation.

7.4 Gas Supply

1. The gas installation should be in accordance with the relevant standards. In GB this is BS 6891. In IE this is the current edition of I.S. 813 “Domestic Gas Installations”.

2. The connection to the appliance is a 22mm copper tail located at the rear of the gas service cock (Fig. 7).

3. Ensure that the pipework from the meter to the appliance is of adequate size. Do not use pipes of a smaller diameter than the boiler gas connection (22mm).

7.5 Electrical Supply

1. External wiring must be correctly earthed, polarised and in accordance with relevant regulations/rules. In GB this is the current I.E.E. Wiring Regulations. In IE reference should be made to the current edition of ETCI rules.

2. The mains supply must be 230V ~ 50Hz and fused at 3A maximum.

NOTE: The method of connection to the electricity supply must facilitate complete electrical isolation of the appliance.

Connection may be via a fused double-pole isolator with a contact separation of at least 3mm in all poles and servicing the boiler and system controls only.

3. When the system includes an indirect domestic hot water cylinder it is recommended that a cylinder thermostat is used in conjunction with a 3 port 2 position valve or 2 port zone valve.

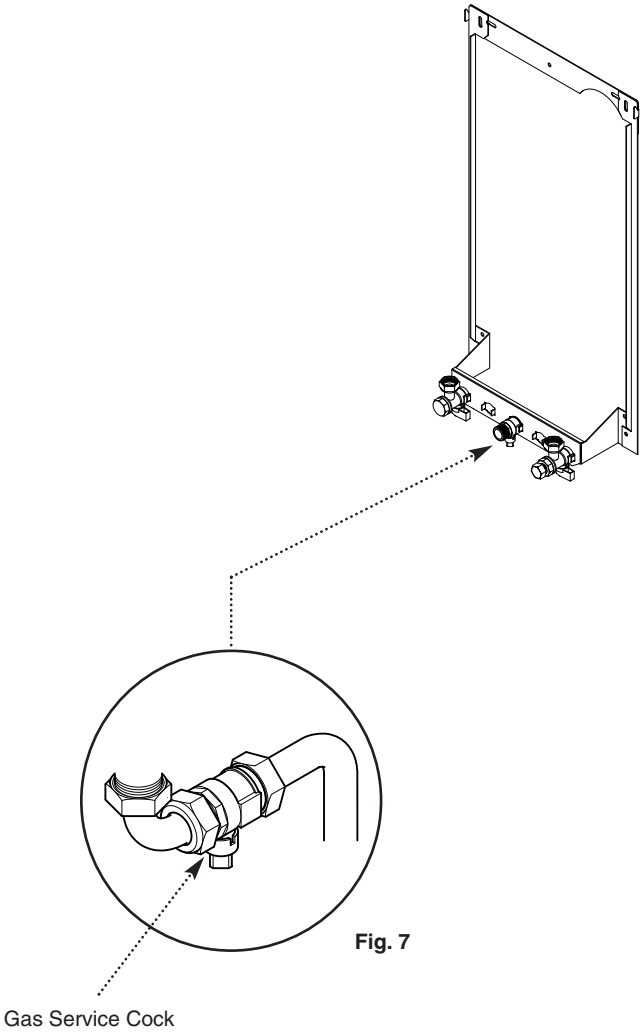

7.0 SITE REQUIREMENTS

7.6 Condensate Drain

FAILURE TO INSTALL THE CONDENSATE DISCHARGE PIPEWORK CORRECTLY WILL AFFECT THE RELIABLE OPERATION OF THE BOILER

The condensate discharge pipe **MUST NOT RISE** at any point along its length. There **MUST** be a fall of **AT LEAST 2.5° (50mm per metre)** along the entire run.

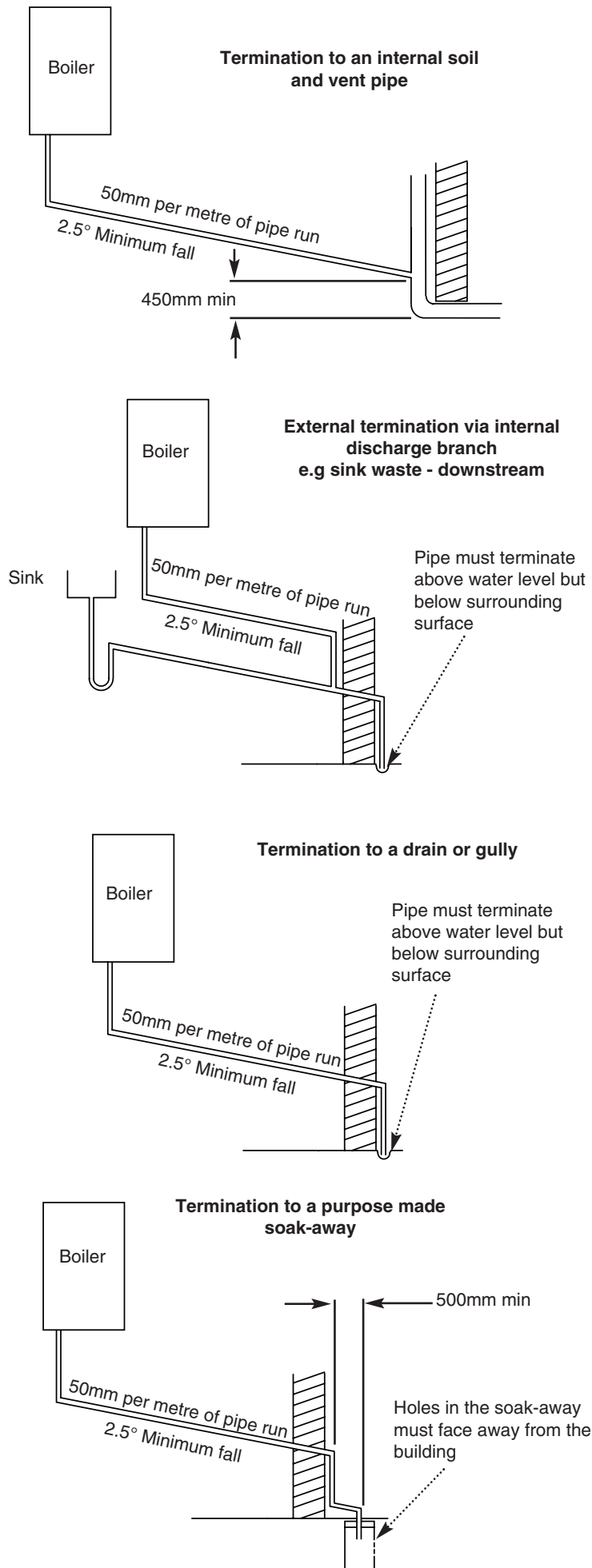

1. The condensate outlet terminates in a 1" BSP nut and seal for the connection of 21.5mm (³/₄in) plastic overflow pipe which should generally discharge internally into the household drainage system. If this is not possible, discharge into an outside drain is acceptable.

2. Ensure the discharge of condensate complies with any national or local regulations in force.

BS 6798:2000 & Part H1 of the Building Regulations give further guidance.

3. The discharge pipe should be run in a proprietary drain pipe material e.g. PVC, PVC-U, ABS, PVC-C or PP.

4. Metal pipework is **NOT** suitable for use in condensate discharge systems.

5. The pipe should be a minimum of 21.5mm diameter and must be supported using suitably spaced clips to prevent sagging.

6. Any pipe fitted externally must not exceed 3 metres.

7. Any condensate discharge pipework external to the building (or in an unheated part of it e.g. garage) must be insulated to protect against frost. It is also recommended that the pipe diameter is increased to 32mm.

8. If the boiler is fitted in an unheated location the entire condensate discharge pipe should be treated as an external run.

9. In all cases discharge pipe must be installed to aid disposal of the condensate. To reduce the risk of condensate being trapped, as few bends and fittings as possible should be used.

10. When discharging condensate into a soil stack or waste pipe the effects of existing plumbing must be considered. If soil pipes or waste pipes are subjected to internal pressure fluctuations when WC's are flushed or sinks emptied then back-pressure may force water out of the boiler trap and cause appliance lockout.

Examples are shown of the following methods of termination:-

- i) to an internal soil & vent pipe
- ii) via an internal discharge branch (e.g. sink waste)
- iii) to a drain or gully
- iv) to a purpose made soakaway

7.0 SITE REQUIREMENTS

7.7 Flue

NOTE: Due to the nature of the boiler a plume of water vapour will be discharged from the flue. This should be taken into account when siting the flue terminal.

1. the following guidelines indicate the general requirements for siting balanced flue terminals. For GB recommendations are given in BS 5440 Pt 1. For IE recommendations are given in the current edition of I.S. 813 "Domestic Gas Installations".

2. If the terminal discharges onto a pathway or passageway, check that combustion products will not cause a nuisance and that the terminal will not obstruct the passageway.

3. If a terminal is less than 2 metres above a balcony, above ground or above a flat roof to which people have access, then a suitable terminal guard must be provided.

Terminal Position with Minimum Distance (Fig. 9) (mm)

A*	Directly below an openable window, air vent or any other ventilation opening.	300
B	Below gutter, drain/soil pipe.	25
C	Below eaves.	25
D	Below a balcony/car port roof.	25
E	From vertical drain pipes and soil pipes.	25
F	From internal or external corners.	25
G	Above adjacent ground or balcony level.	300
H	From a surface facing a terminal.	600
I	Facing a terminals.	1200
J	From opening (door/window) in carport into dwelling.	1200
K	Vertically from a terminal on the same wall.	1500
L	Horizontally from a terminal on the same wall.	300
M*	Above an opening, air brick, opening window etc.	300
N*	Horizontally to an opening, air brick, opening window etc.	300

* In addition, the terminal should be no nearer than 150mm to an opening in the building fabric formed for the purpose of accommodating a built-in element such as a window frame. See BS 5440 Pt. 1.

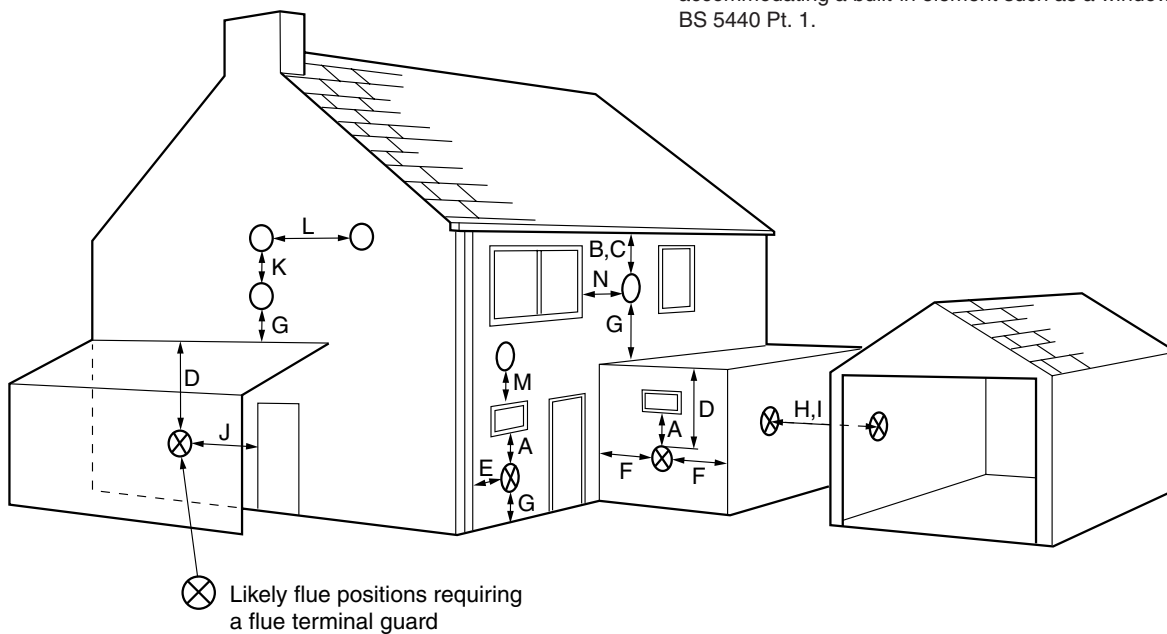

Fig. 9

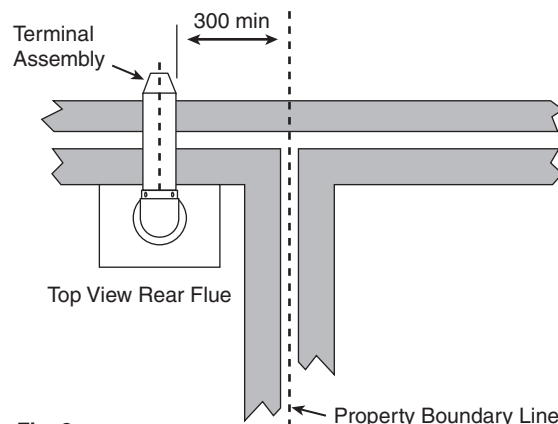

Fig. 8

7.0 SITE REQUIREMENTS

7.8 Flue Dimensions

The standard horizontal flue kit allows for flue lengths between 100mm and 685 from elbow to terminal (Fig. 10).

The maximum permissible equivalent flue length is:

System 12 & 18 HE	5 metres
System 24 HE	4 metres
System 28 HE	3 metres

7.9 Flue Trim

1. The rubber flue trim supplied may be fitted to either the outside wall or on the inner wall of installation.

7.10 Terminal Guard (Fig. 11)

1. When codes of practice dictate the use of terminal guards, they can be obtained from most Plumbers' and Builders' Merchants.

2. There must be a clearance of at least 50mm between any part of the terminal and the guard.

3. When ordering a terminal guard, quote the appliance name and model number.

4. The flue terminal guard should be positioned centrally over the terminal and fixed as illustrated.

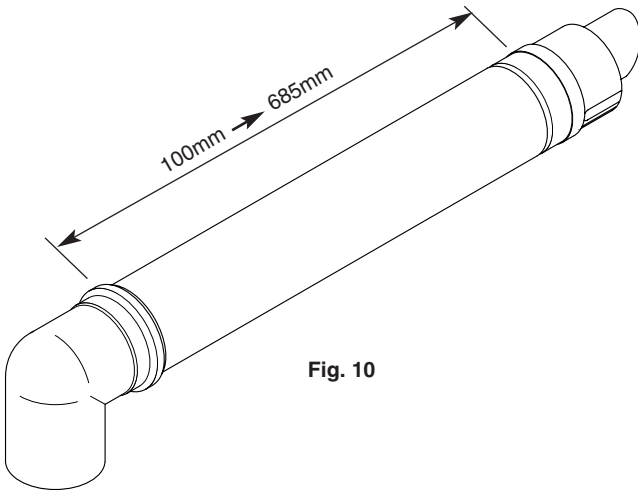

Fig. 10

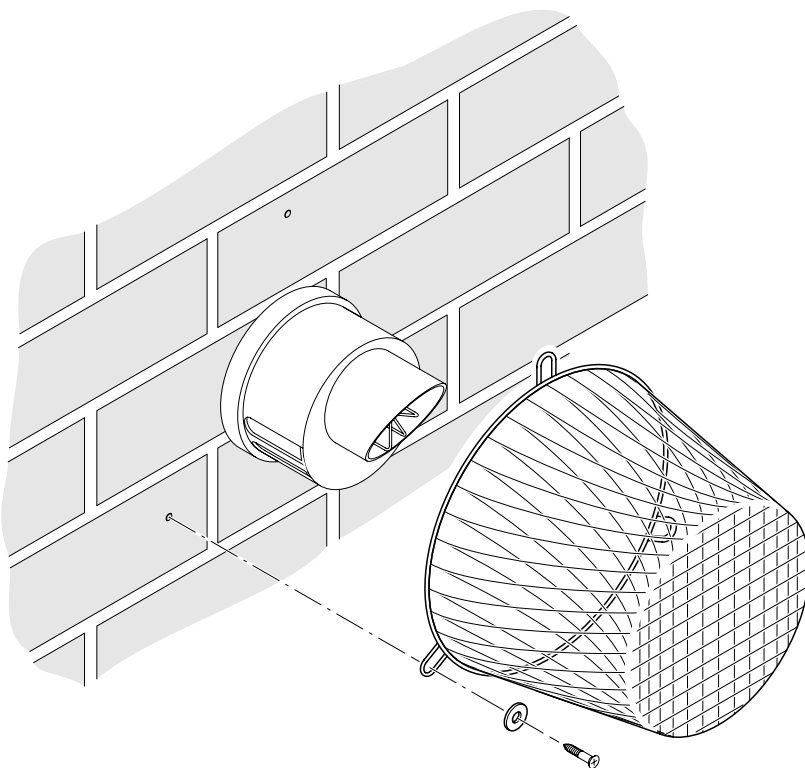

Fig. 11

7.0 SITE REQUIREMENTS



7.11 Flue Options

1. The Potterton Performa System HE range can be fitted with flue systems as illustrated.

2. The standard flue is suitable only for horizontal applications.

3. Maximum permissible equivalent flue lengths are:-

	12,18	24	28
Concentric	5m	4m	3m
Vertical	5m	4m	3m
Vertical Twin Pipe	10m	12m	12m

4. Any additional "in line" bends in the flue system must be taken into consideration.

Their equivalent lengths are:-

Concentric Pipes:

45° bend	0.5 metres
93° bend	1.0 metres

Twin Flue Pipe

45° bend	0.25 metres
91.5° bend	0.50 metres

The elbow supplied with the standard horizontal flue is not included in any equivalent length calculations

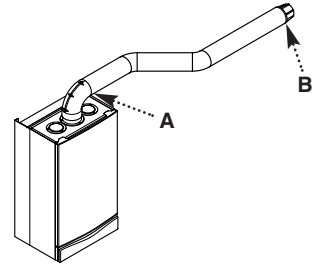
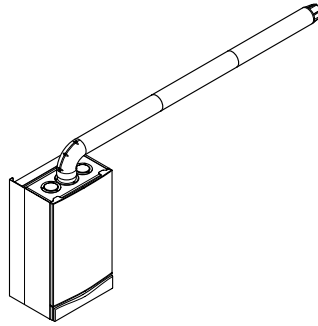

Horizontal Flues

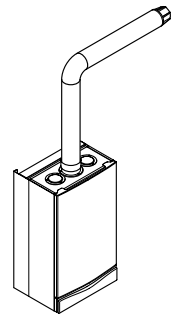
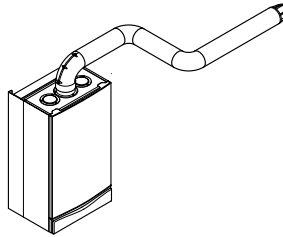

NOTE: Flue length is measured from point A to B as shown.

Vertical Flues (Twin Pipe)

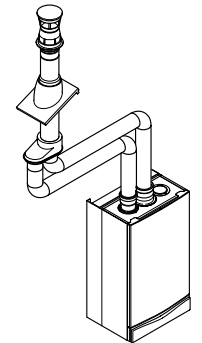
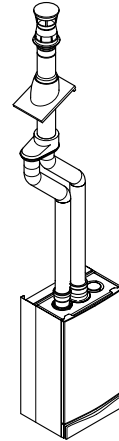
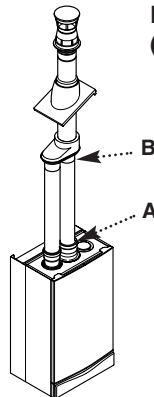

Vertical Flues

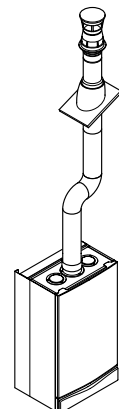
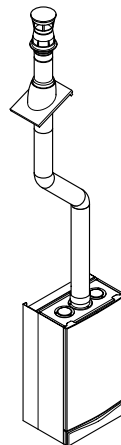
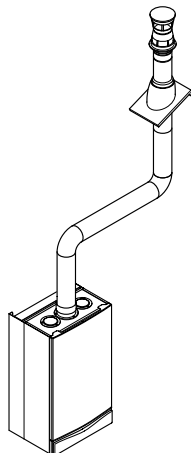
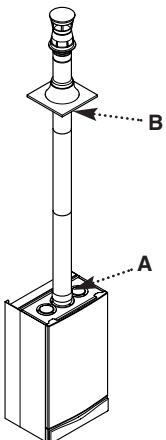

8.0 INSTALLATION

8.1 Initial Preparation

The gas supply, gas type and pressure must be checked for suitability before connection (see Section 7.4).

1. After considering the site requirements (see Section 7.0) position the fixing template on the wall ensuring it is level both horizontally and vertically.

2. Mark the position of the two most suitable fixing slots for the wall plate and boiler lower fixing holes. It is preferable to use the horizontal fixing slots.

3. Mark the position of the centre of the flue hole (rear exit). For side flue exit, mark as shown (Fig. 12).

4. Note the shaded area on the template. Pipework may be routed upwards behind the boiler, providing it does not conflict with the shaded area.

5. If required, mark the position of the gas and water pipes. Remove the template.

6. Cut the hole for the flue (minimum diameter 116mm).

7. Drill the wall as previously marked to accept the wall plugs supplied. Secure the wall plate using the fixing screws.

8. Using a spirit level ensure that the plate is level before finally tightening the screws.

9. Connect the gas and water pipes to the valves on the wall plate using the copper tails supplied. Ensure that the sealing washers are fitted between the connections.

8.2 Flushing

1. Connect a tube to the central heating flow or return pipe (Fig. 13).

2. Flush thoroughly (see System Details, Section 6.1).

8.3 Preparing The Boiler

1. Remove all packaging.

2. Stand the boiler on its base by using the rear lower edge as a pivot.

NOTE: A small amount of water may drain from the boiler in the upright position.

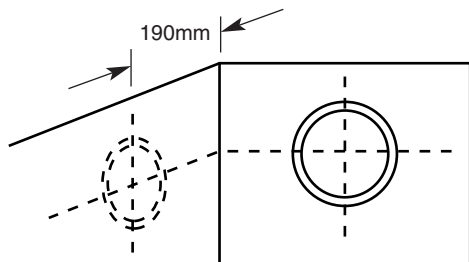

For Side Flue Exit

Fig. 12

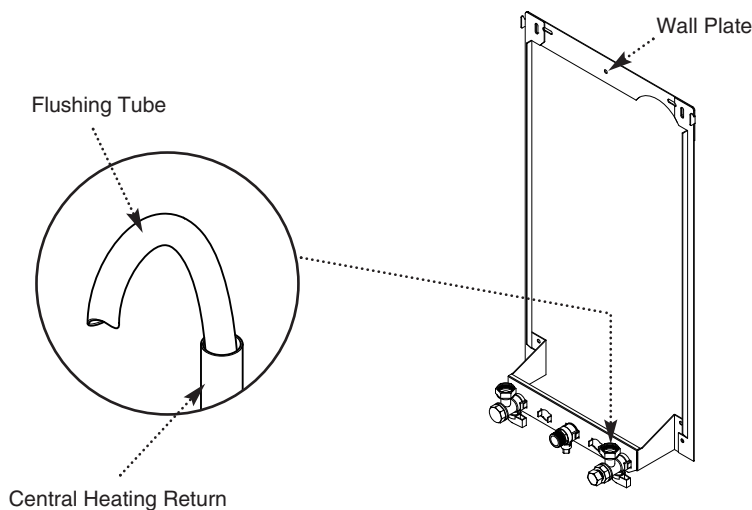

Fig. 13

8.0 INSTALLATION

POTTERTON

8.4 Fitting The Boiler

1. Remove the sealing caps from the boiler connections.
2. Lift the boiler using the lower edges. Engage the slots at the top rear of the boiler on the wall plate (Fig. 14).
3. Insert the sealing washers between the valves and pipes on the wall plate and the boiler connections. **The rubber washers must be used on the gas connection.**
4. Tighten all the connections.

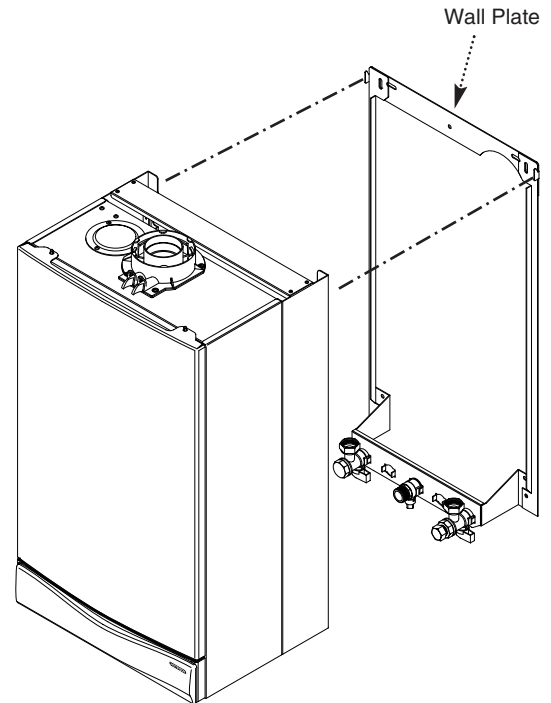

Fig. 14

8.5 Fitting the Pressure Relief Discharge Pipe (Fig. 15)

1. Remove the discharge pipe from the kit.
2. Determine the routing of the discharge pipe in the vicinity of the boiler. Make up as much of the pipework as is practical, including the discharge pipe supplied.
3. The pipework must be at least 15mm diameter and run continuously downwards to a discharge point outside the building. See section 6.6 for further details.
4. Utilising one of the sealing washers, connect the discharge pipe to the adaptor and tighten the nut.
5. Complete the discharge pipework and route it to the outside discharge point.

IMPORTANT: Make all soldered joints before connecting to the pressure relief valve.

8.6 Condensate Drain (see section 7.6)

1. Connect the condensate drain using the 1" BSP nut and seal supplied.

Ensure the discharge of condensate complies with any national or local regulations in force (see British Gas "Guidance Notes for the Installation of Domestic Gas Condensing Boilers").

2. The condensate outlet terminates in a 1" BSP nut and seal for the connection of 21.5mm ($\frac{3}{4}$ in) plastic overflow pipe which should generally discharge internally into the household drainage system. If this is not possible, discharge into an outside drain is acceptable.

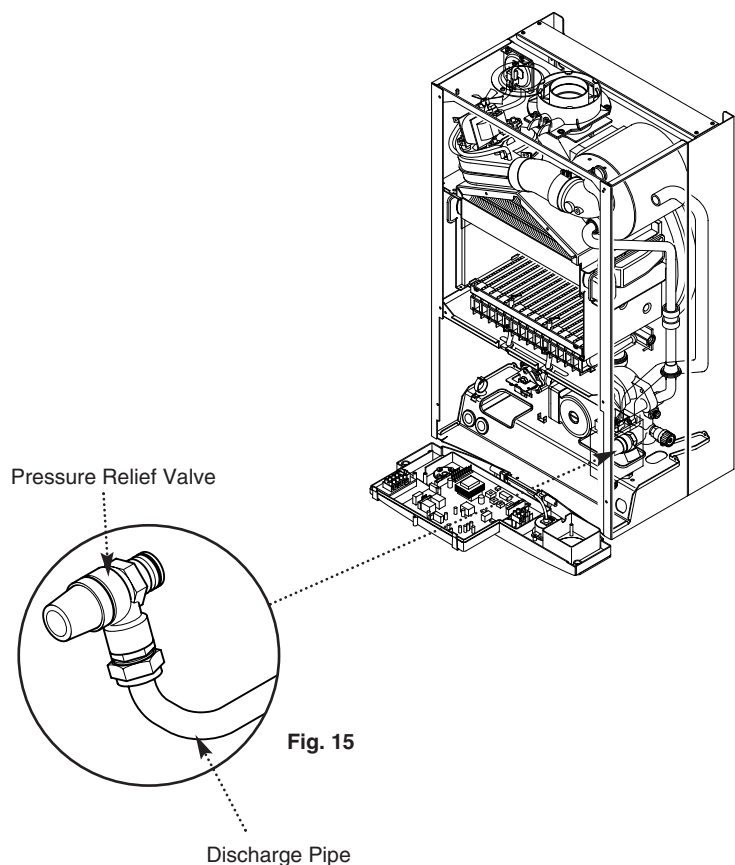

8.0 INSTALLATION

8.7 Fitting The Flue

HORIZONTAL FLUE

1. The standard flue is suitable for lengths between 100mm minimum and 685mm maximum, as measured from the edge of the flue elbow outlet to the joint between the terminal and air duct (Fig. 16).

2. Locate the flue elbow on the adaptor at the top of the boiler. Set the elbow to the required orientation (Fig. 17).

NOTE: The flue elbow is angled at 93 degrees to ensure a fall back to the boiler.

3. Measure the distance from the outside wall face to the elbow. This dimension will be known as 'X' (Fig. 18).

4. To dimension 'X' add 50mm. This dimension to be known as 'Y'.

IMPORTANT: Check all dimensions before cutting.

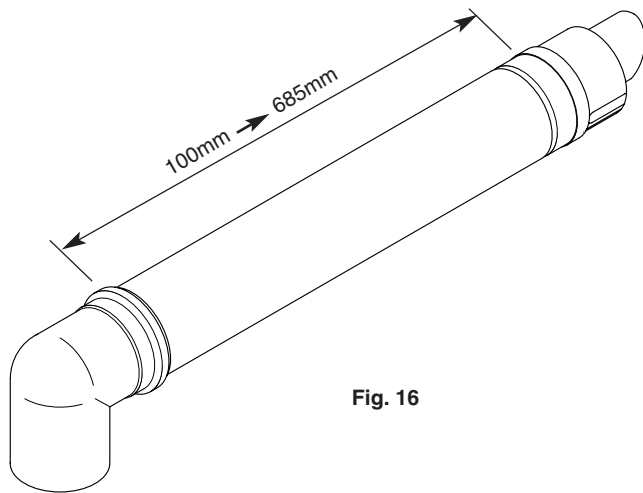

Fig. 16

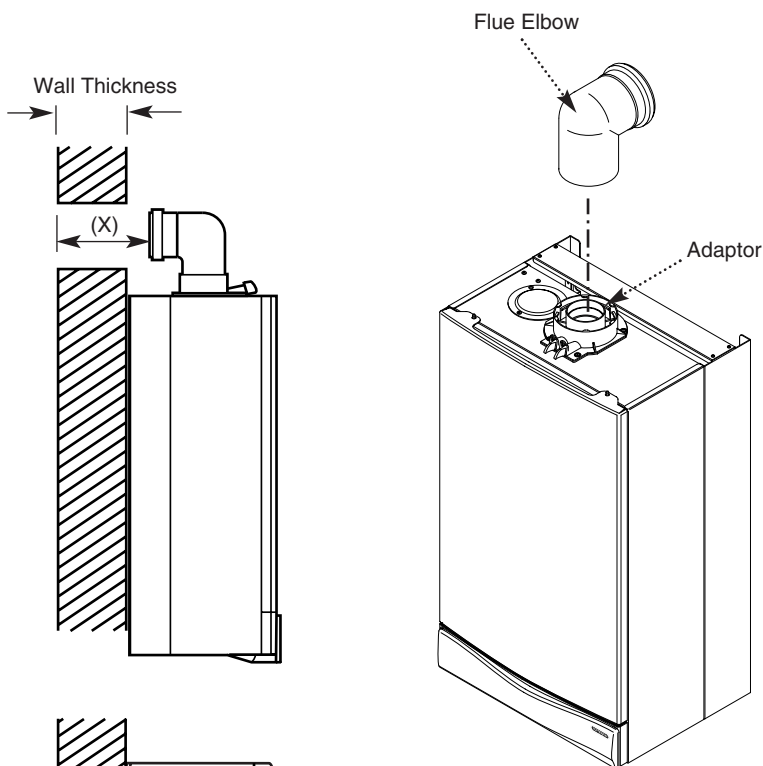

Fig. 17

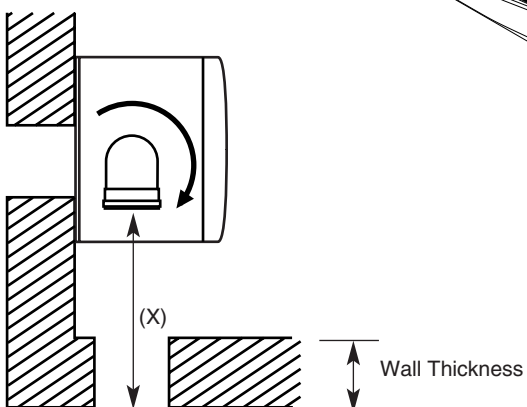

Fig. 18

8.0 INSTALLATION



8.7 Fitting the Flue (Cont)

5. Mark dimension 'Y' on the flue as shown (Fig. 19). Carefully cut the waste material from the flue, ensuring that the ducts are square and free from burrs.

6. The inner flue duct support bracket may be in the waste portion of the flue. In this case retrieve the bracket before discarding the waste.

7. Take the inner flue support bracket (if not already fitted) and engage it over the flue duct. This will centralise the flue and air ducts, and ease assembly (Fig. 20).

8. Insert the flue through the hole in the wall. Fit the elbow to the boiler adaptor, ensuring that it is pushed fully in.

9. Draw the flue back through the wall and engage it in the elbow. It may be necessary to use soap solution or similar to ease assembly of the elbow adaptor and flue (Fig. 21).

10. Make good between the wall and air duct outside the building.

11. Fit the flue trim if required, and if necessary fit a terminal guard (see Section 7.9 & 7.10).

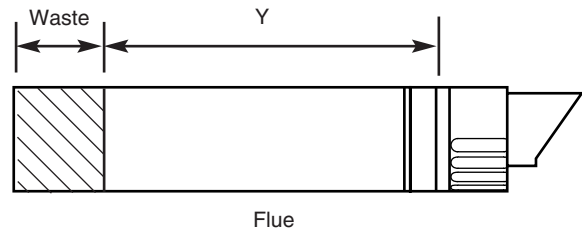

Fig. 19

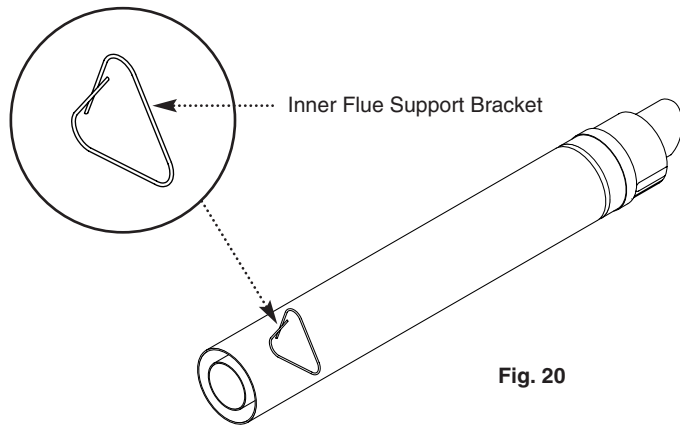

Fig. 20

VERTICAL FLUE

1. Only a flue approved with the Potterton Performa System HE range can be used.

2. For information on vertical flues consult the Potterton Flue Guide brochure.

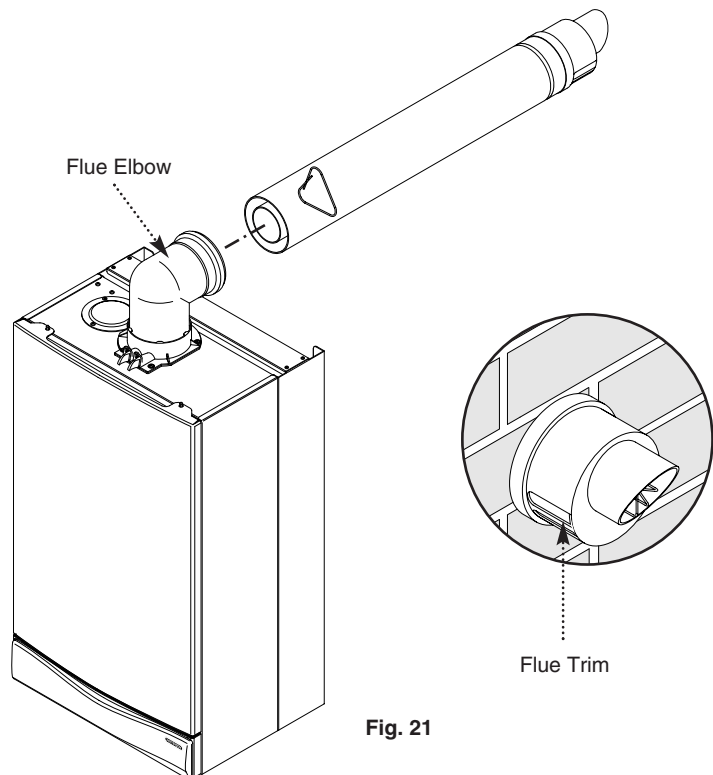

Fig. 21

8.0 INSTALLATION

8.8 Making The Electrical Connections

To connect the mains input cable proceed as follows:-

1. Slacken the fascia securing screws and lift the outercase panel so that its securing tabs are clear of the fascia. Remove the panel.
2. Completely undo the screws securing the fascia panel and hinge it down (Fig. 22).
3. Remove the control box cover securing screws. Disengage the barbs on the control box from the cover. Remove the cover (Fig. 23).
4. Slacken the cable clamp on the LH side of the boiler chassis (Fig. 24). Insert the cable through the clamp and route it to the terminal block.
5. Slacken the screws in the terminal block, connect the input cable, and tighten the screws.
6. Run the input cable from any external control through the second cable clamp on the boiler chassis. Refer to the instructions supplied with the control.
7. To connect external control(s) remove the link between terminals 1 & 2. The switched output from the external control must be connected to terminal 2 (Fig. 25).

IMPORTANT: The external control **MUST** be suitable for 230V switching and fused 3A maximum

8. Ensure that both mains input and any external control input cables have sufficient slack to allow the control box to drop down. Tighten the cable clamp(s) on the boiler chassis.

8.9 Preliminary Electrical Checks

1. Prior to commissioning the boiler preliminary electrical system checks should be carried out.
2. These should be performed using a suitable meter, and include checks for Ground Continuity, Resistance to Ground, Short Circuit and Polarity.

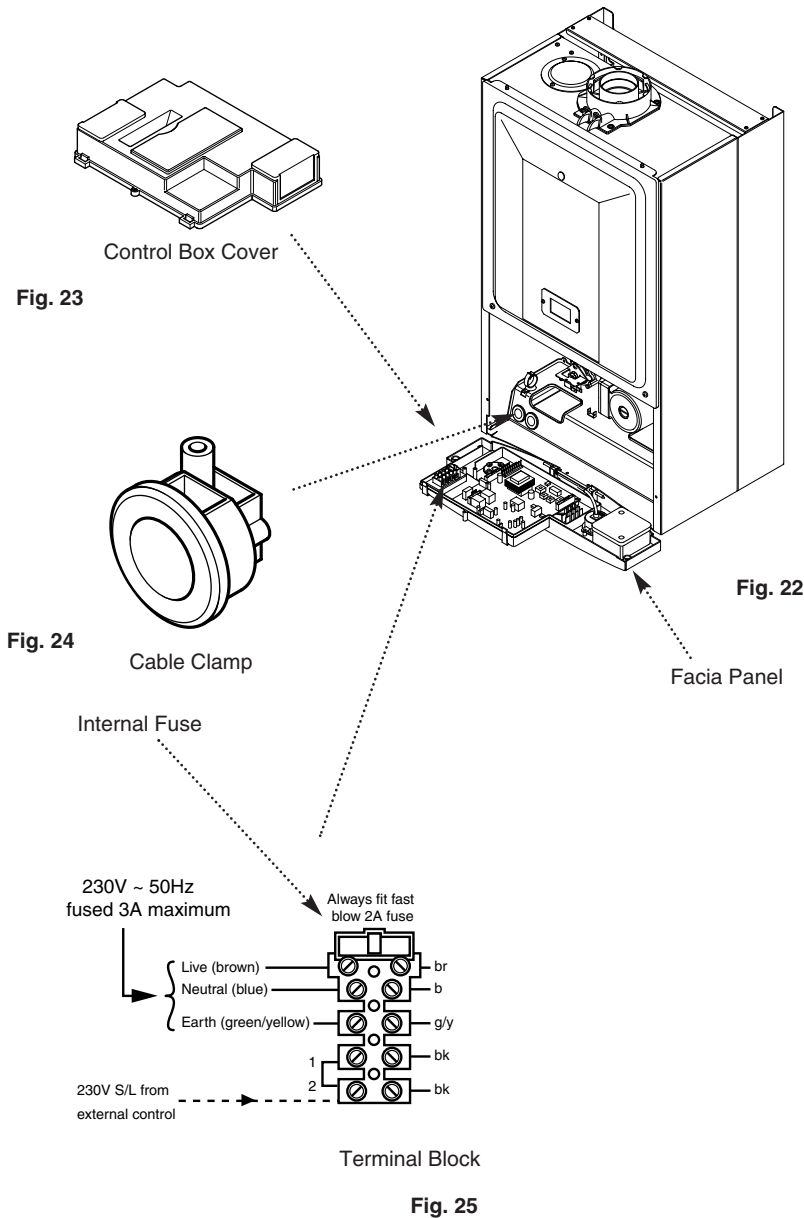

Functional Flow Diagram

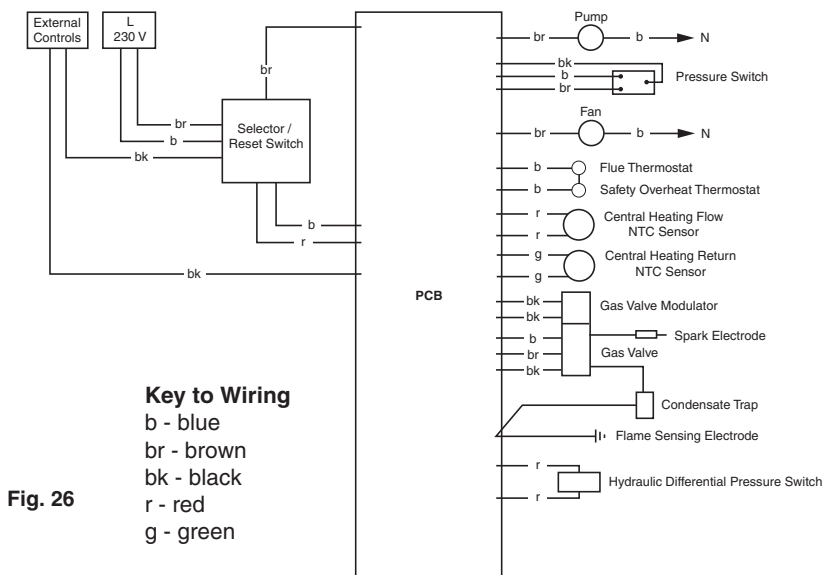

9.0 COMMISSIONING

9.1 Commissioning the Boiler

1. Reference should be made to BS 5449 when commissioning the boiler.
2. Ensure that the filling loop is connected and open, then open the heating flow and return valves on the boiler.
3. Open the screw on the automatic air vent (Fig. 27).
4. The system must be flushed in accordance with BS 7593 and the flushing agent manufacturers instructions.
5. Pressurise the system to 1.0 bar then close and disconnect the filling loop.
6. Turn the gas supply on and purge the system according to in GB BS 6891 and in IE I.S. 813 "Domestic Gas Installations".
7. Test for gas soundness.
8. If at any time during commissioning it is required to terminate a particular cycle, e.g. the pump overrun period, turn the selector to the Off position and then back to the On position () (Fig. 29).

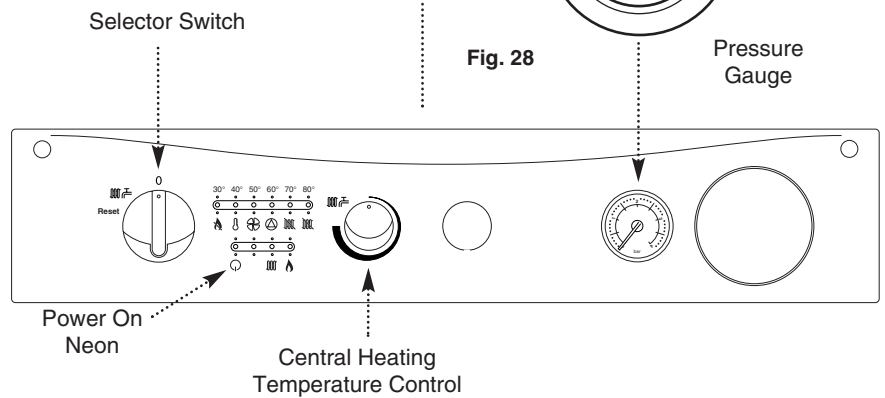
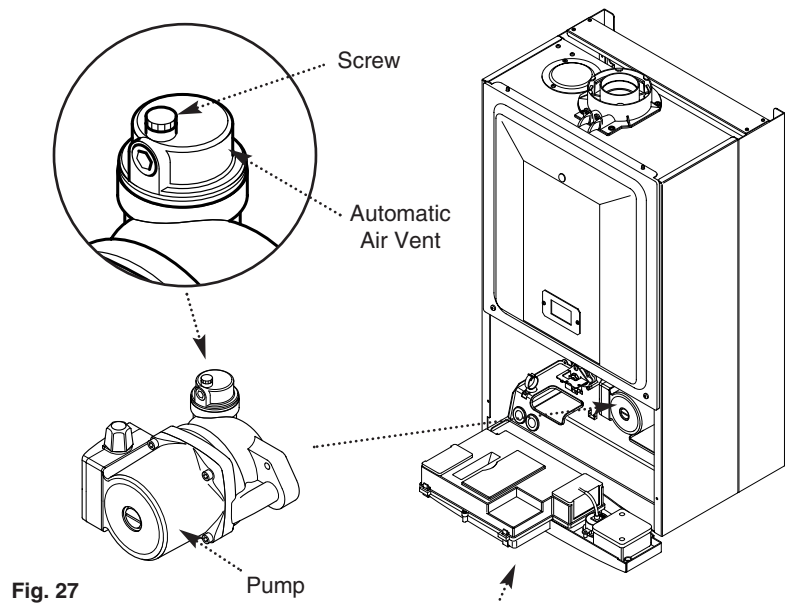

9.0 COMMISSIONING

9.2 Checking the Burner Pressure

1. Turn on the gas and electrical supplies to the boiler and ensure that all external controls are calling for heat.
2. Set the temperature control to maximum and the selector switch to the Off position (Fig. 33).
3. Slacken the pressure test point sealing screw on the gas valve and connect a pressure gauge (Fig. 30).
4. Undo the screws securing the inner door panel. Lift the panel slightly to disengage it from the studs on top of the case.
5. Turn the selector switch fully anticlockwise against the spring pressure to the 'Reset' position and hold for 2 seconds to reset the boiler.
6. Turn the selector switch to the On Position (ON). The power On neon (ON) will illuminate (Fig. 33).
7. The pressure should be as quoted in Section 4.0 Technical Data. If not, check that the gas supply pressure is correct (Natural Gas 20mbar, and Propane 37mbar).
8. The pressure can be adjusted if required.
9. To check and set minimum pressure first remove one of the modulator wires.

Adjusting the Pressure (Fig 31)

10. Remove the plastic protection cap from the pressure adjustment nuts on the valve.
11. The smaller nut (5mm) adjusts minimum pressure and the larger nut (8mm) maximum pressure.
12. Using a suitable spanner adjust the relevant nut until the correct pressure is achieved.
13. Once the pressure has been set turn the boiler off and disconnect the pressure gauge.
14. Tighten the pressure test screw and refit the modulator to the valve. Reassemble in reverse order.

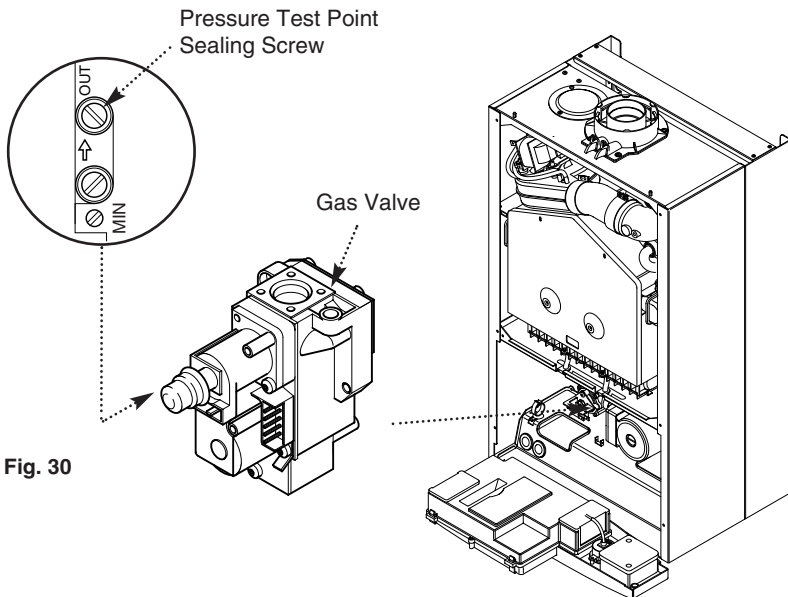

Fig. 30

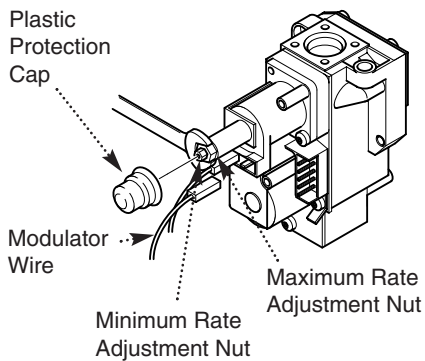

Fig. 31 **NOTE:** Gas Valve Electrical Plug/Igniter not shown for clarity

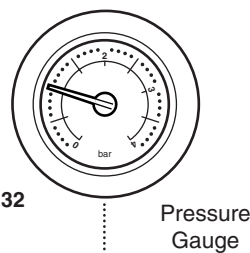

Fig. 32

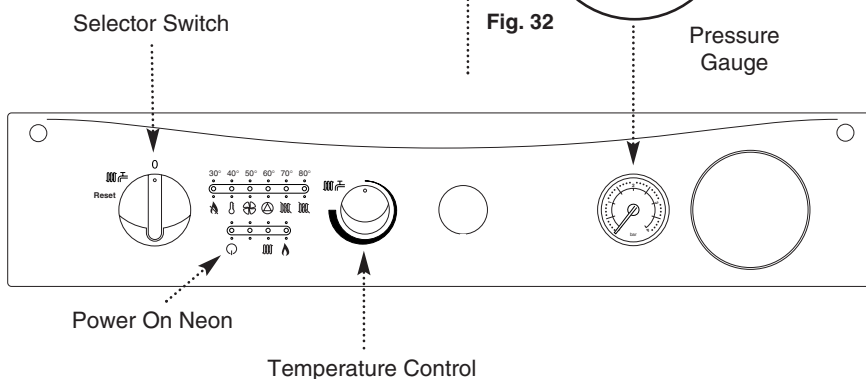

Fig. 33

10.0 COMPLETION



10.1 Completion

1. Hinge the facia panel upwards and refit the case front panel. Tighten the securing screws (Fig. 34).
2. Instruct the user in the operation of the boiler and system, explaining the operational sequence.
3. Carefully read and complete all sections of the Benchmark Commissioning Checklist at the rear of this publication that are relevant to the appliance and installation. These details will be required in the event of any warranty work. The publication must be handed to the user for safe keeping and each subsequent regular service visit recorded.
4. For IE, it is necessary to complete a "Declaration of Conformity" to indicate compliance with I.S. 813. An example of this is given in I.S. 813 "Domestic Gas Installations". This is in addition to the Benchmark Commissioning Checklist.
5. Hand over the Users Operating, Installation and Servicing Instructions, giving advice on the necessity of regular servicing.

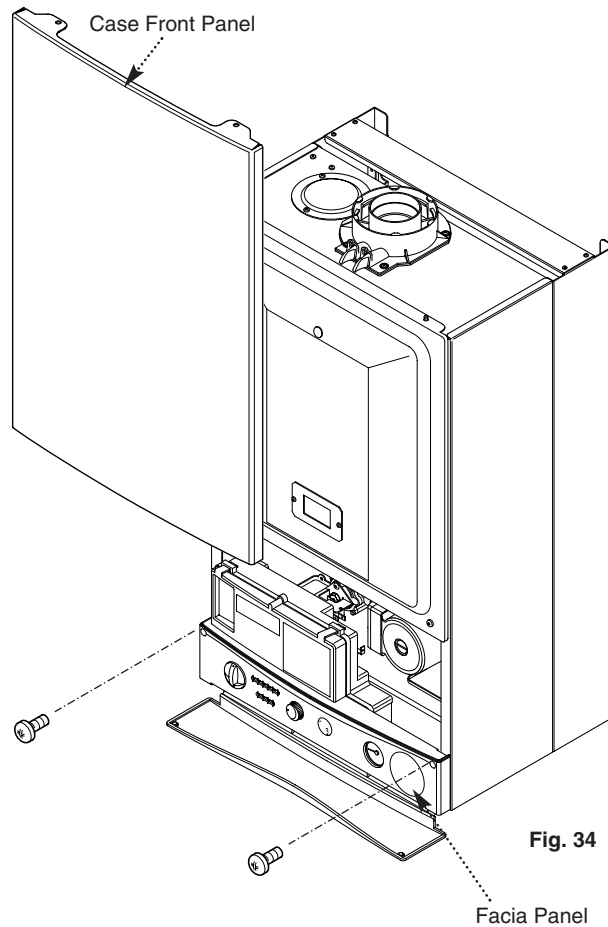

11.0 SERVICING

11.1 Annual Servicing

1. For reasons of safety and economy, it is recommended that the boiler is serviced annually. Servicing must be performed by a competent person.

2. After servicing, complete the relevant Service Interval Record section of the Benchmark Commissioning Checklist at the rear of this publication.

3. Ensure that the boiler is cool.

4. **Ensure that both the gas and electrical supplies to the boiler are isolated.**

5. Slacken the screws securing the fascia panel. Lift the outercase panel so that its securing tabs are clear of the fascia. Remove the panel, allowing the fascia to hinge down (Fig. 35).

6. Remove the screws securing the inner door panel. Lift the panel slightly to disengage it from the studs on top of the case (Fig. 37).

7. Note the positions of the sensing tube(s) (28 HE has two - one tube on 12/18/24 HE) on the fan spigot and three wires on the fan motor and remove them (Fig. 36).

8. Slacken the screws on the fan spigot outlet pipe clamps. Ease the clamps inwards over the pipe (28 HE). On 12/18/24 HE models undo the securing screw at the left hand end of the pipe and the clamp at the right.

9. Draw the outlet pipe away from the boiler.

10. Remove the four screws securing the combustion box door and remove the door (Fig. 37).

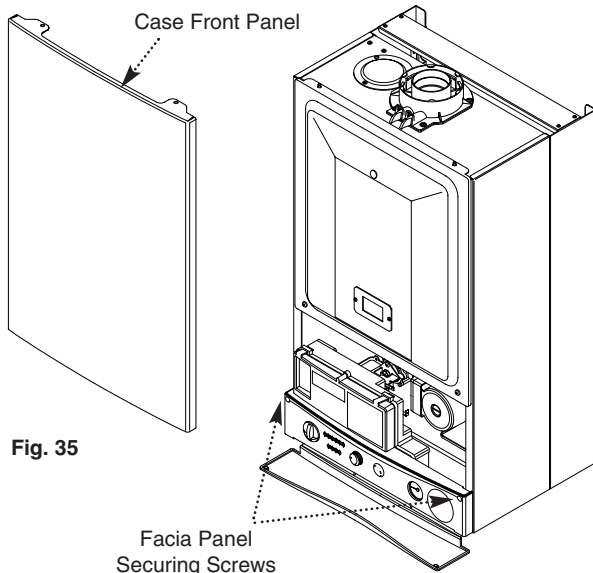
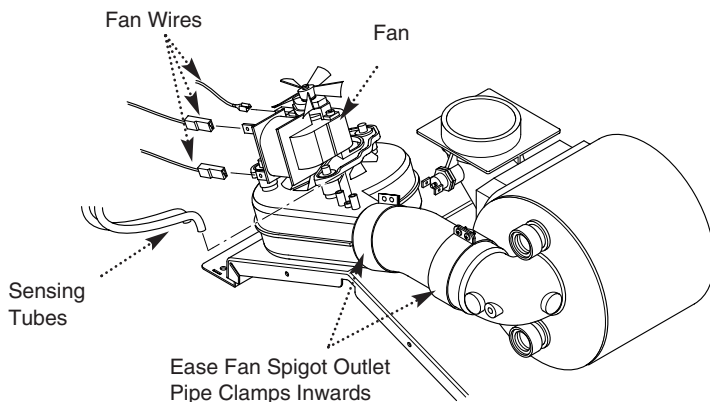

Fig. 35



28 model

Fan Spigot Outlet Pipe

Fig. 36

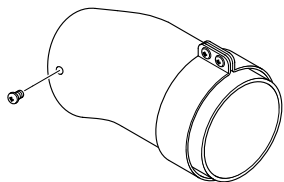

12,18,24 model

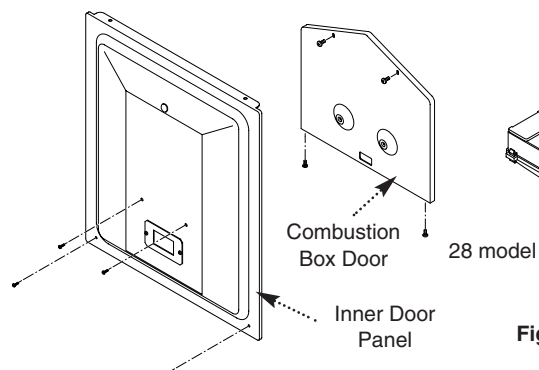

Fig. 37

11.0 SERVICING



11.1 Annual Servicing (Cont)

12. Ease the front edge of the left hand baffle upwards, disengaging the spring clip. Disengage the tabs on the baffle from the slots in the fan hood (Fig. 38).

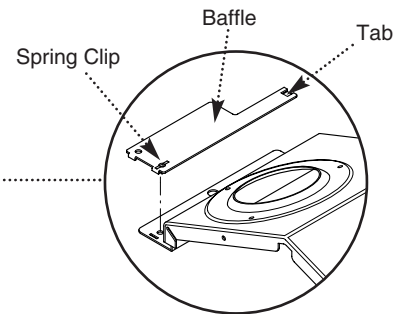

13. Undo the screws securing the fan and hood to the appliance back panel. Draw the assembly forwards (Fig. 39).

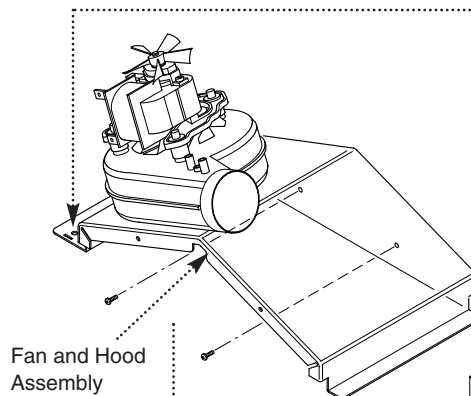

14. On 28 HE models undo the screws securing the burner to the injector manifold.

15. Draw the burner out of the combustion box, pulling the electrode grommets from the slots in the combustion box lower panel (Fig. 40).

16. Disconnect the electrode leads and grommets from the electrodes. Completely remove the burner (Fig. 40).

17. Brush any deposits from the injectors. Do not use a pin or wire to clean them.

18. Brush the burner blades and venturis and clean the combustion box.

19. Ensure that the heat exchanger fins are clear of any obstruction.

NOTE: If necessary the secondary heat exchanger may be dismantled - see section 12.23.

20. Check that the pressure vessel charge is 0.5bar and reassemble in reverse order of dismantling.

21. Turn the selector switch fully anticlockwise against the spring pressure to position R and hold for 2 seconds to reset the boiler before recommissioning.

22. Complete the relevant Service Interval Record section of the Benchmark Commissioning Checklist at the rear of this publication and then hand it back to the user.

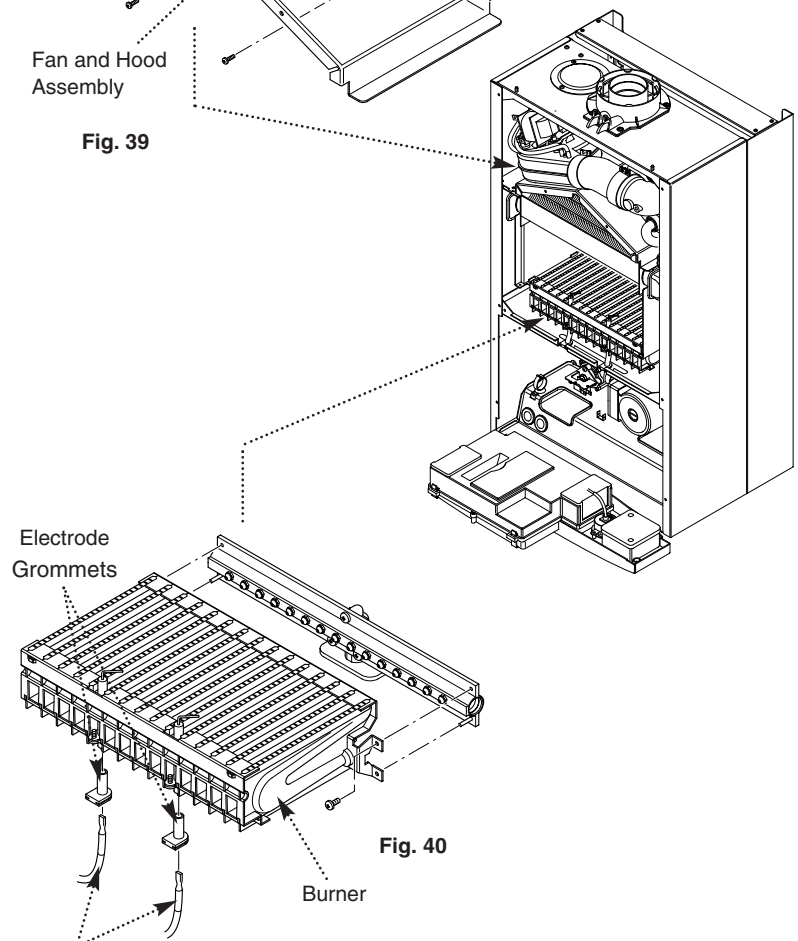

12.0 CHANGING COMPONENTS

IMPORTANT: When changing components ensure that both the gas and electrical supplies to the boiler are isolated before any work is started. When the new component has been fitted turn the selector switch fully anticlockwise against the spring pressure to the 'Reset' position and hold for 2 seconds to reset the boiler before recommissioning.

See Section 11.1 "Annual Servicing" for removal of case panel, door etc.

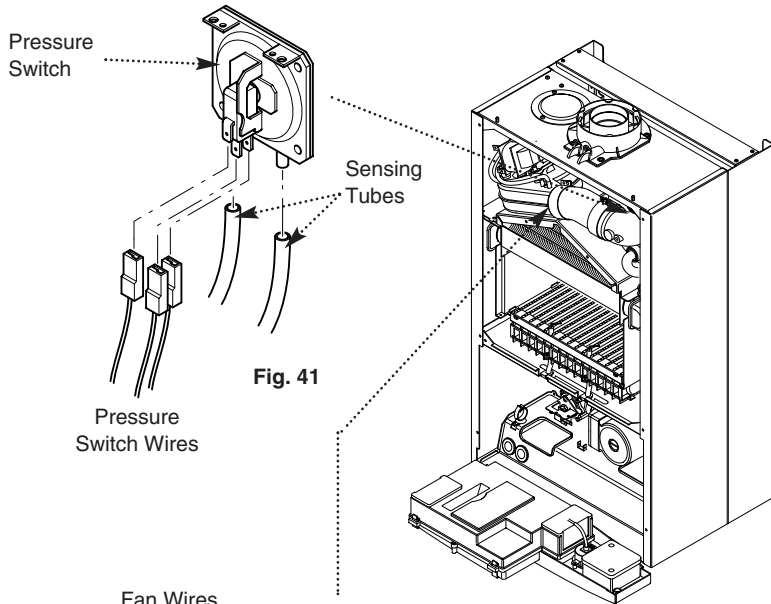

12.1 Fan (Figs. 42 & 43)

1. Note the positions of the sensing tube(s) (28 HE has two - one tube on 12/18/24 HE) on the fan spigot and three wires on the fan motor and remove them.

2. Slacken the screws on the fan spigot outlet pipe clamps. Ease the clamps inwards over the pipe (28 HE). On 12/18/24 HE models undo the securing screw at the left hand end of the pipe and the clamp at the right.

3. Draw the outlet pipe away from the boiler.

4. Remove the four screws securing the combustion box door and remove the door.

5. Ease the front edge of the left hand baffle upwards, disengaging the spring clip. Disengage the tabs on the baffle from the slots in the fan hood.

6. Undo the screws securing the fan hood to the appliance back panel, and draw the fan and hood assembly forwards.

7. Remove the screws and spring washers securing the fan to the hood.

8. Fit the new fan to the hood using the screws and spring washers previously removed.

9. Reassemble in reverse order of dismantling.

12.2 Pressure Switch (Fig. 41)

1. Remove the fan as described in section 12.1.

2. Note the positions of the two sensing tubes and three wires and remove them.

3. Remove the two screws holding the pressure switch to the bracket on the combustion box top panel.

4. Fit the new pressure switch and reassemble all components in reverse order of dismantling.

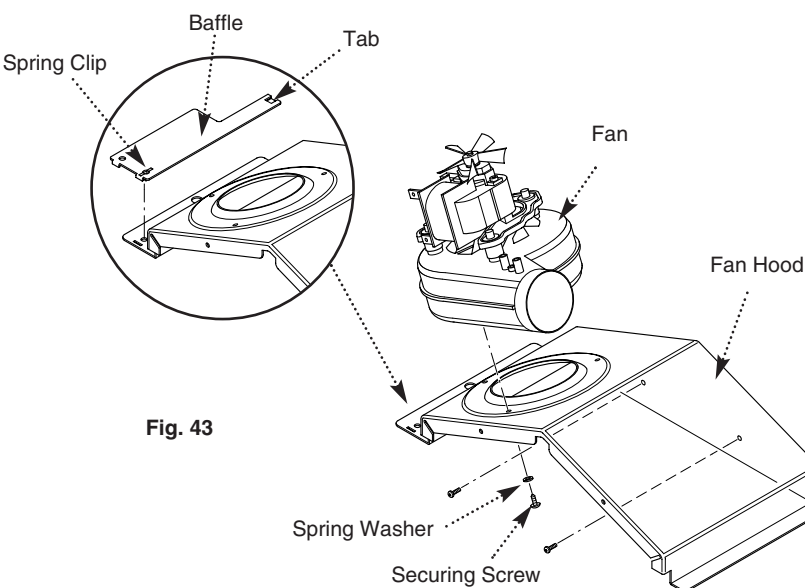
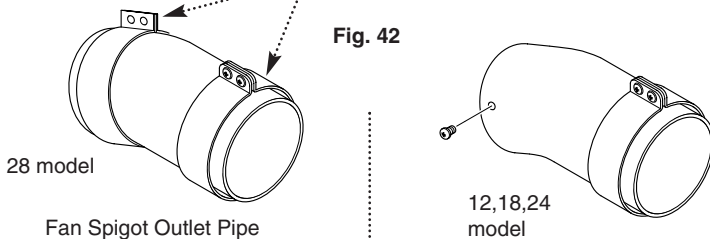
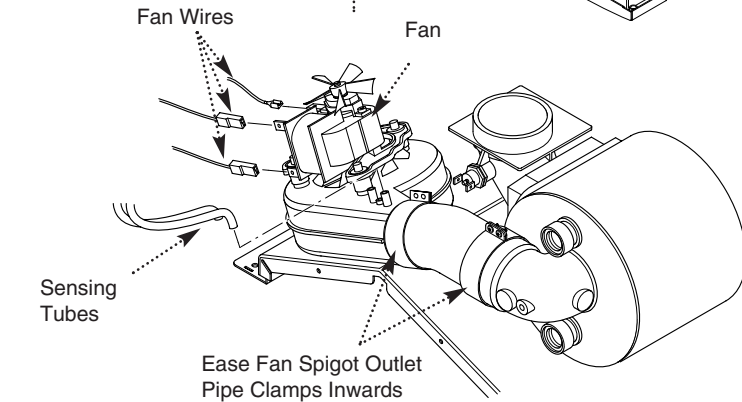

12.0 CHANGING COMPONENTS



12.3 Heat Exchanger (Fig. 44)

1. Remove the fan as described in section 12.1.
2. Drain the primary circuit. Prise the pipe connecting clips off the joints in the flow and return pipes. Remove the heat exchanger return pipe.
3. Lift the heat exchanger to disconnect the flow pipe joint. Withdraw it from the appliance, taking care not to damage the rear insulation piece.
8. Fit the new heat exchanger.
9. Reassemble in reverse order of dismantling, and repressurise the system.

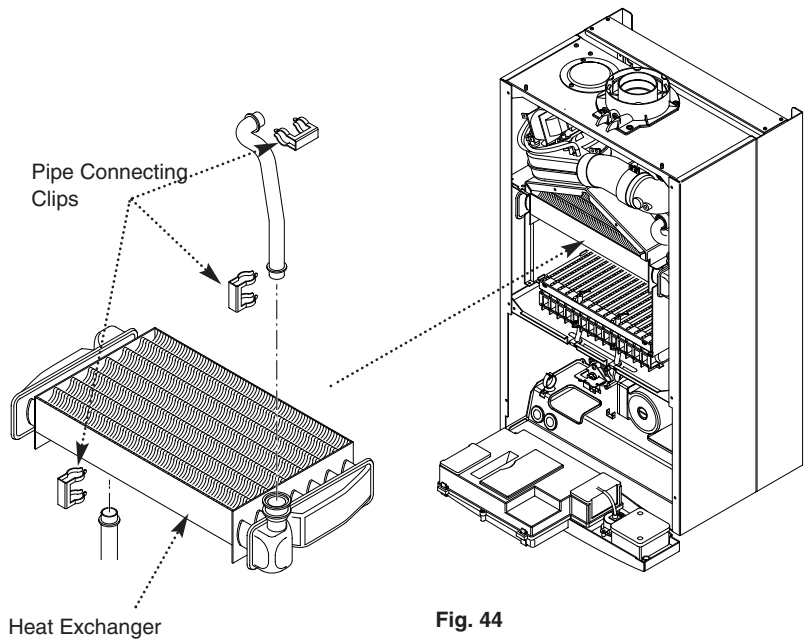

Fig. 44

12.4 Burner (Fig. 45)

1. Remove the four screws securing the combustion box door and remove the door.
2. On 28 HE models undo the screws securing the burner to the injector manifold.
3. Draw the burner out of the combustion box, pulling the electrode grommets from the slots in the combustion box lower panel.
4. Disconnect the electrode leads and grommets from the electrodes. Completely remove the burner.
5. Undo the screws securing the electrodes to the burner. Examine the condition of the electrodes, replacing if necessary. Fit the electrodes to the new burner.
6. Engage the burner location brackets over the studs on the injector manifold and reassemble in reverse order.

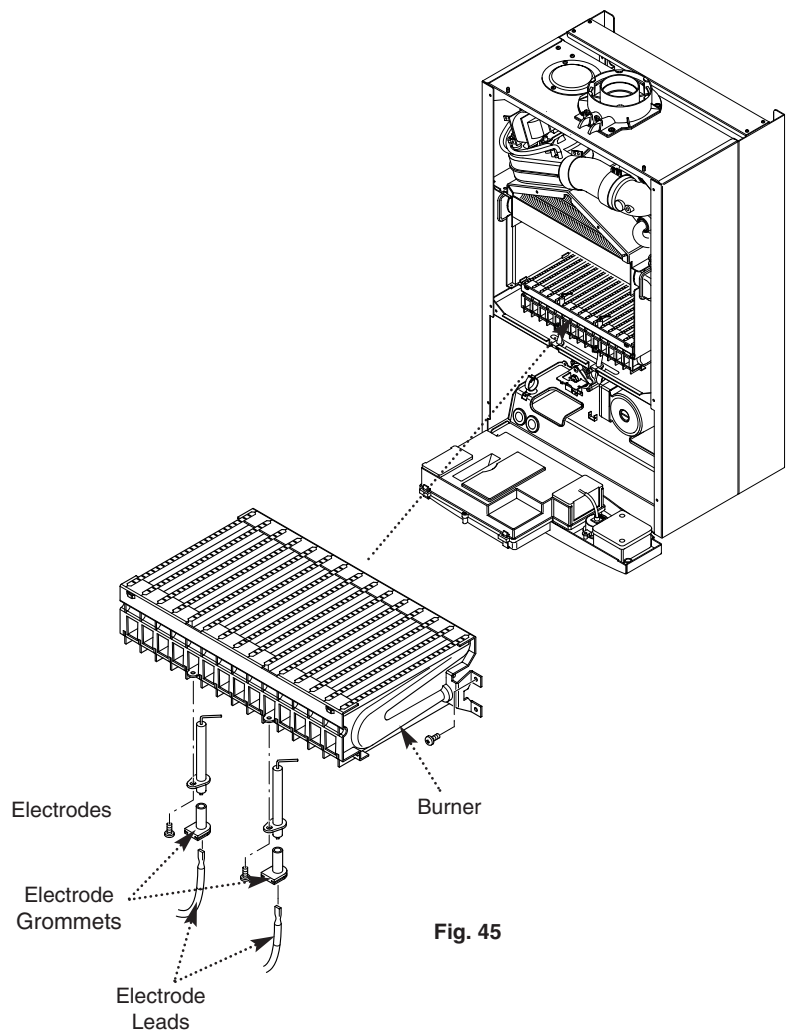

Fig. 45

12.0 CHANGING COMPONENTS

12.5 Injectors (Fig. 46)

1. Remove the burner as described in Section 12.4.
2. Undo the screws securing the injector manifold to the inlet elbow and remove the manifold.
3. Unscrew and replace injectors as required and examine the sealing gasket, replacing as necessary. Reassemble in reverse order.

12.6 Electrodes (Fig. 46)

1. Remove the four screws securing the combustion box door and remove the door.
2. Undo the screws securing the burner to the injector manifold. Draw the burner out of the combustion box, pulling the electrode grommets from the slots in the combustion box lower panel.
3. Disconnect the lead and grommet from the electrode being replaced. Undo the securing screw and withdraw the electrode to the burner.
4. Reassemble in reverse order.

12.7 Insulation (Fig. 47)

1. Remove the four screws securing the combustion box door and remove the door.
2. Slide the side insulation pieces carefully out of their carriers.
3. To replace the rear insulation piece it is necessary to remove the heat exchanger as described in Section 12.3 and slide out the side pieces.
4. The combustion box door insulation piece can be replaced by carefully bending up the two retaining tabs.
5. Replace all insulation pieces and reassemble in reverse order.

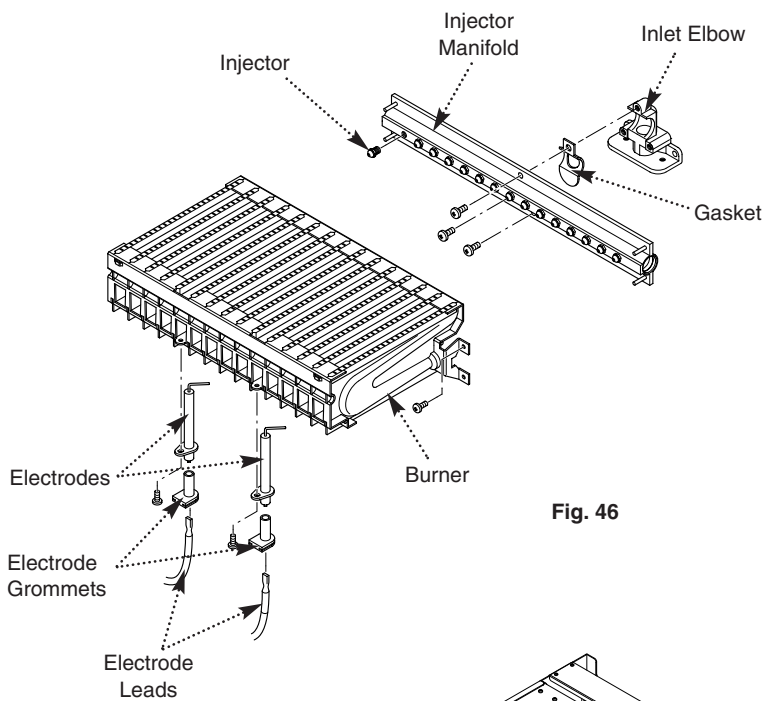

Fig. 46

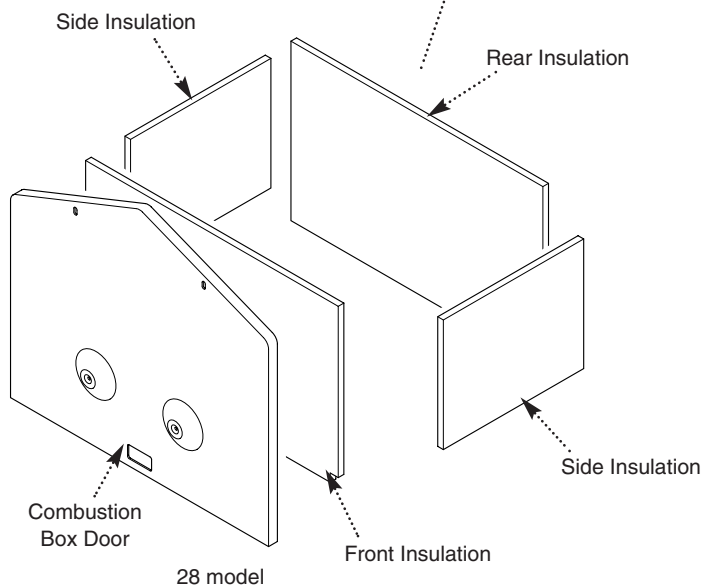
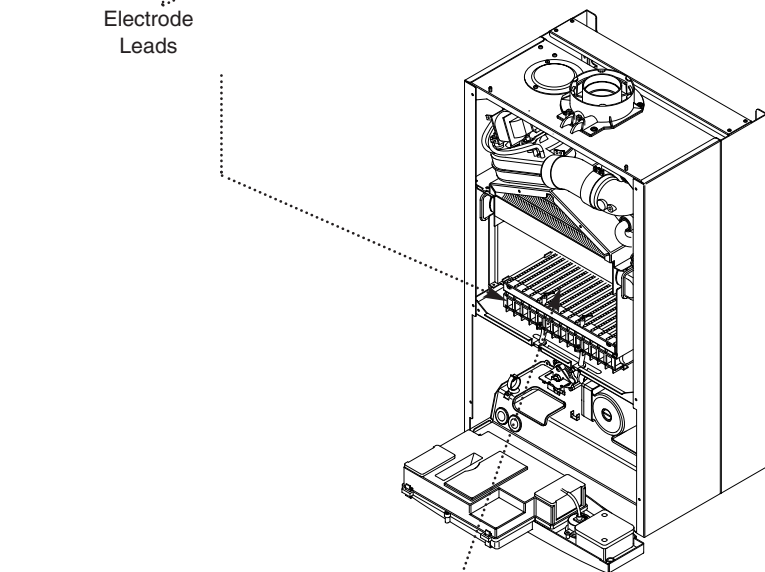

Fig. 47

12.0 CHANGING COMPONENTS

12.8 Gas Valve (Fig. 48)

1. Undo the nut on the gas feed pipe under the boiler.
2. Completely undo the securing screws and hinge the facia panel down.
3. Disconnect the wires from the valve modulator and the ignition lead from the spark generator. Disconnect the pressure sensing pipe from the valve. Undo the screw securing the spark generator electrical plug to the valve and disconnect the plug.
4. Pull the earth wire off the spade terminal on the valve.
5. Remove the screws securing the inlet pipe flange to the boiler bottom panel and those securing the outlet manifold to the burner manifold.
6. Remove the valve from the boiler.
7. Note the orientation of the inlet pipe and outlet manifold. Undo the securing screws and remove the pipe and manifold.
8. Examine the 'O' ring seals for damage, replacing as necessary.
9. Fit the inlet pipe and outlet manifold to the new valve, ensuring that the 'O' ring seals are in place.
10. Reassemble in reverse order and check the burner pressure as described in Section 9.2.

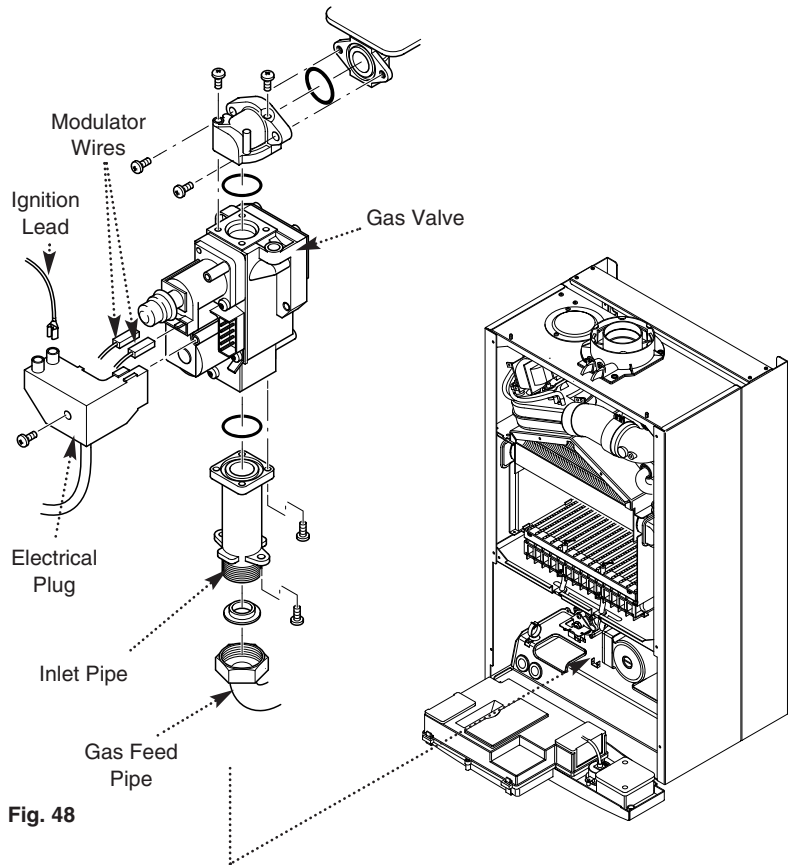

Fig. 48

12.9 Central Heating Temperature Sensor (Fig. 49)

1. Ease the retaining tab on the sensor away and disconnect the electrical plug.
2. Unscrew the sensor from its pocket and reassemble in reverse order. The plug will only fit one way.

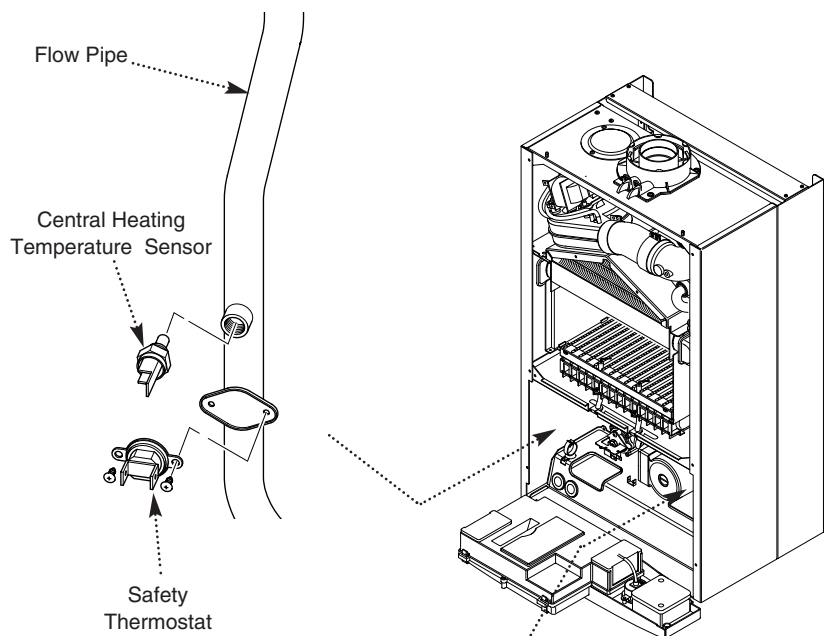

Fig. 49

12.10 Safety Thermostat (Fig. 49)

1. Pull the electrical connections off the thermostat.
2. Remove the screws securing the thermostat to the mounting plate on the flow pipe.
3. Reassemble in reverse order. The thermostat is not polarised - either wire can fit either terminal on the thermostat.

12.11 Return Heating Temperature Sensor (Fig. 50)

1. Ease the retaining tab on the sensor away and disconnect the electrical plug.
2. Prise the sensor retaining clip off the pipe and remove the sensor from the clip.
3. Reassemble in reverse order.

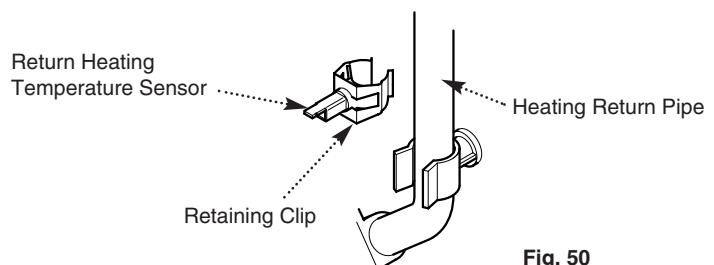

Fig. 50

12.0 CHANGING COMPONENTS

12.12 Pump - Head Only (Fig. 51)

1. Drain the primary circuit and remove the socket head screws securing the pump head to the body and draw the head away.
2. Undo the screw on the pump wiring cover and remove the cover. Using a suitable flat bladed screw driver press the cable securing levers downwards to release each wire after noting their position.
3. A standard replacement Grundfos 15-60 head can now be fitted. Connect the pump wiring to the new head. **The pump speed must be set to 3** (Fig. 52).
4. Reassemble in reverse order.

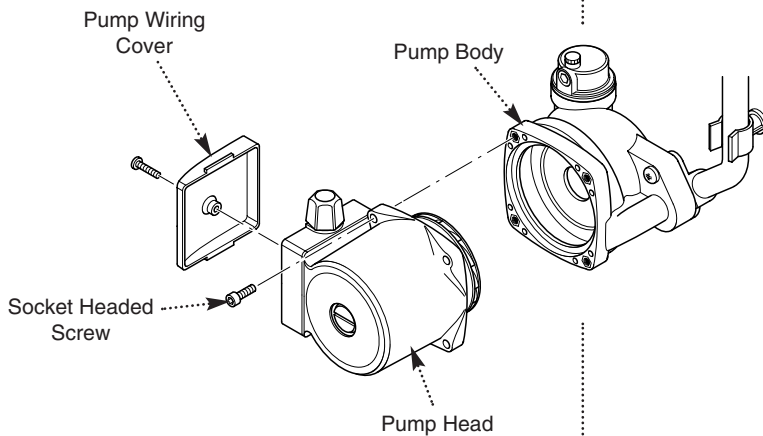
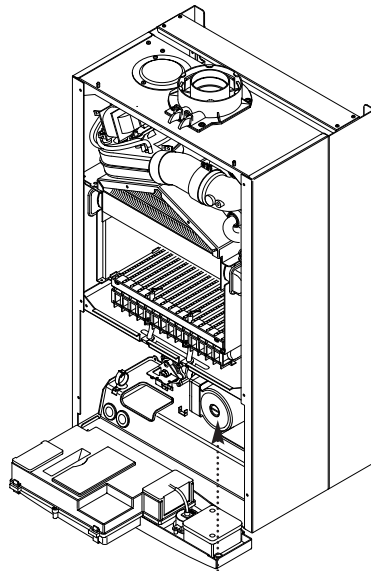
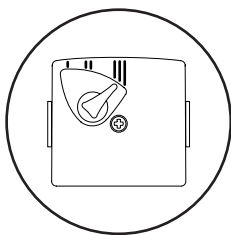

Fig. 51



Pump Setting

Fig. 52

12.13 Pump - Complete (Fig. 53)

1. Drain the primary circuit and unscrew the automatic air vent from the pump body. Undo the two screws securing the body to the pipe and manifold and draw the pump forwards.
2. Undo the screw on the pump wiring cover and remove the cover. Using a suitable flat bladed screw driver press the cable securing levers downwards to release each wire after noting their position.
3. Connect the wiring to the new pump. Examine the 'O' ring seals on the return pipe and manifold, replacing if necessary.
4. Fit the air vent to the pump body and reassemble in reverse order.

Automatic Air Vent

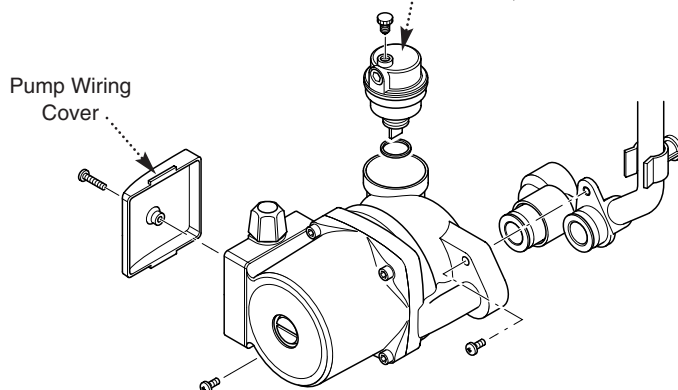

Fig. 53

12.14 Automatic Air Vent (Fig. 53)

1. Drain the primary circuit and unscrew the automatic air vent from the pump body.
2. Examine the 'O' ring seal, replacing if necessary, and fit it to the new automatic air vent.
3. Reassemble in reverse order.

12.0 CHANGING COMPONENTS



12.15 Pressure Gauge (Figs. 54 & 55)

1. Drain the primary circuit and undo the nut on the pressure gauge capillary.
2. Remove the timer cover and ease the timer wiring aside. Undo the screws securing the gauge retaining bracket.
3. Remove the bracket and gauge assembly. Depress the barbs on the side of the gauge and remove the retaining bracket.
4. Reassemble in reverse order.

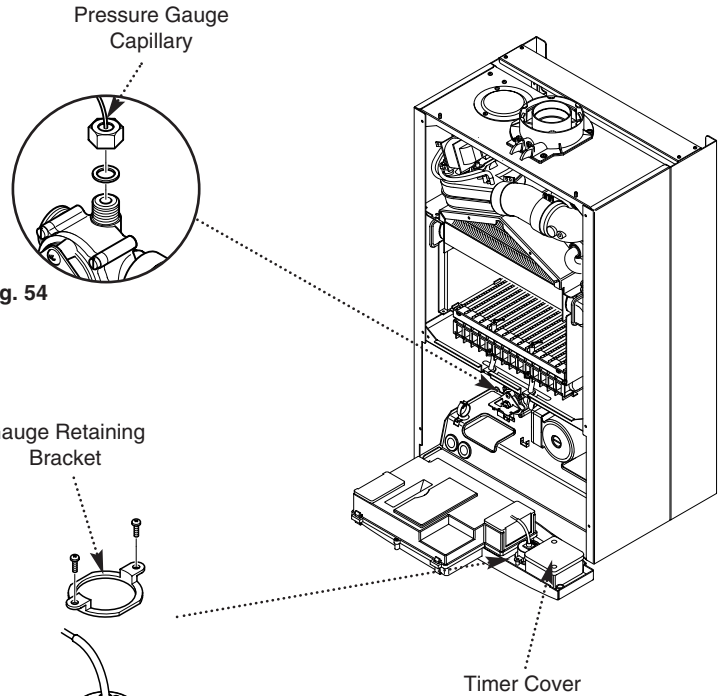

Fig. 54

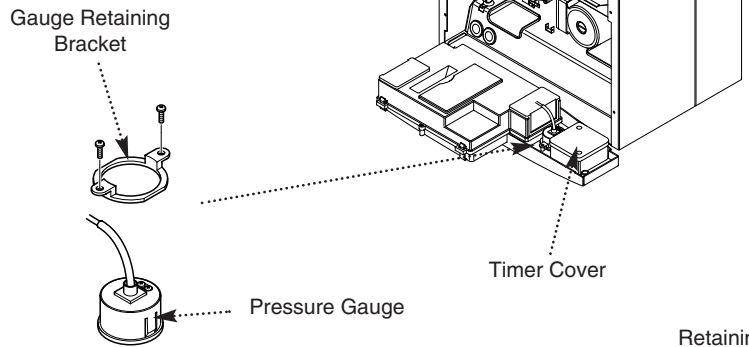

Fig. 55

NOTE: Alternatively a vessel of equivalent capacity can be fitted on the system return pipe as close as possible to the boiler.

2. Drain the system and undo all gas, water and condensate drain connections. Remove the flue elbow.
3. Lift the boiler off the wall plate and lay it on either side on a clean flat surface.
4. Undo the nut on the vessel outlet spigot, and remove the locknut and spring washer securing the spigot to the boiler chassis.
5. Undo the screws and remove the appliance upper cross member. Slide the expansion vessel out of the retaining clips.
6. Reassemble in reverse order. Fully recommission the appliance and system.

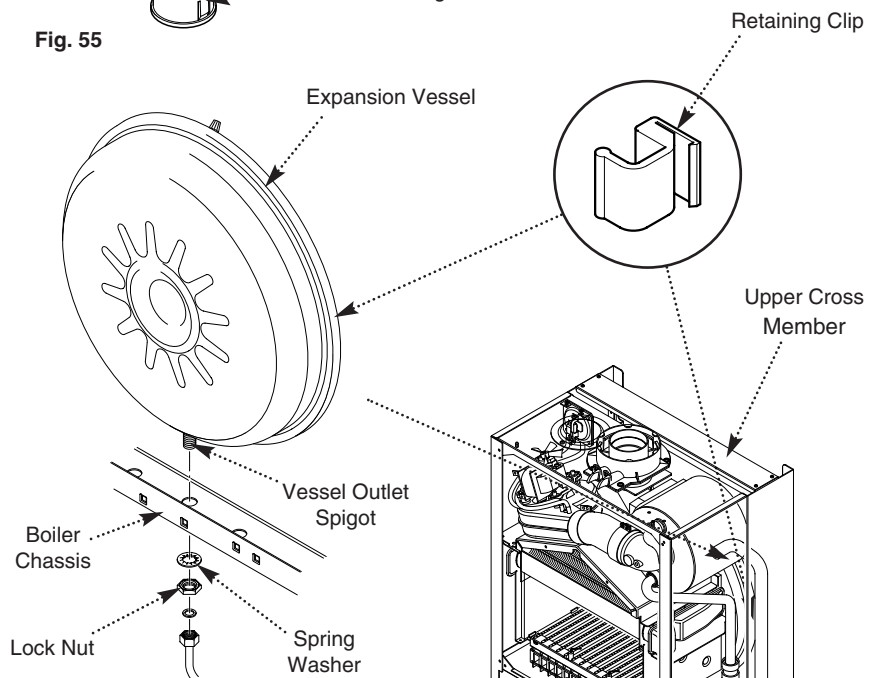

Fig. 56

12.17 Condensate Trap (Fig. 57)

1. Disconnect the two sensing wires from the trap connections.
2. Squeeze together the wire spring clip to release and ease the inlet pipe from the trap spigot.
3. Undo the nut securing the condensate drain pipe to the trap. Disconnect the pipe and sealing washer.
4. From underneath the boiler remove the screws securing the trap bracket.
5. Remove the trap and bracket from the boiler. Undo the locknut securing the trap to the bracket.
6. Reassemble in reverse order.

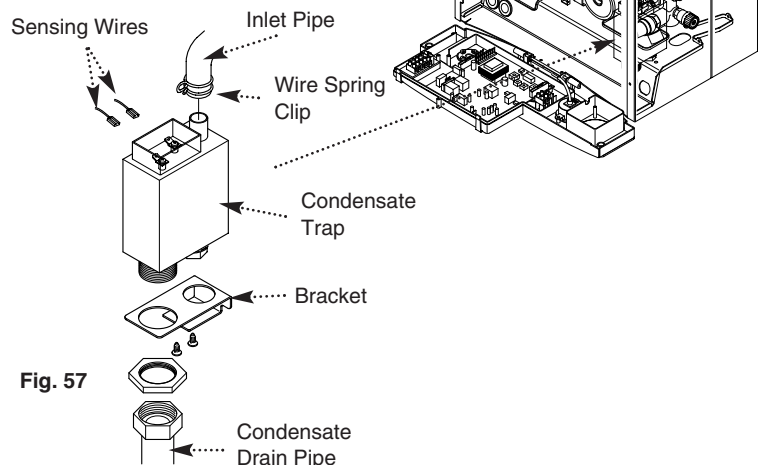

Fig. 57

12.0 CHANGING COMPONENTS

12.18 Main PCB (Fig. 59)

1. Note the setting of the temperature control knob. Rotate the knob fully anticlockwise and carefully pull it off the drive pin.
2. Completely undo the screws securing the control box cover and release the cover retaining barbs from their slots. Disengage the rear of the cover from the control box hinge pin (Fig. 58).
3. Note the position of all plugs and wires on the PCB and disconnect them.
4. Undo the securing screws and remove the PCB. Transfer the control knob drive pin to the new PCB and turn it fully anticlockwise.
5. Reassemble in reverse order, ensuring that the temperature controller is reset to the previous position.
6. Ensure that the DHW potentiometer is fully anticlockwise once the new PCB is fitted.

12.19 Selector Switch (Fig. 59)

1. Note the setting of the selector switch knob and carefully pull it off the facia.
2. Completely undo the screws securing the control box cover and release the cover retaining barbs from their slots. Disengage the rear of the cover from the control box hinge pin (Fig. 58).
3. Note the position of the electrical connections and the orientation of the switch. Remove the electrical connections.
4. Remove the screws securing the switch to the facia panel.
5. Fit the new switch, ensuring that it is correctly positioned and reassemble in reverse order.

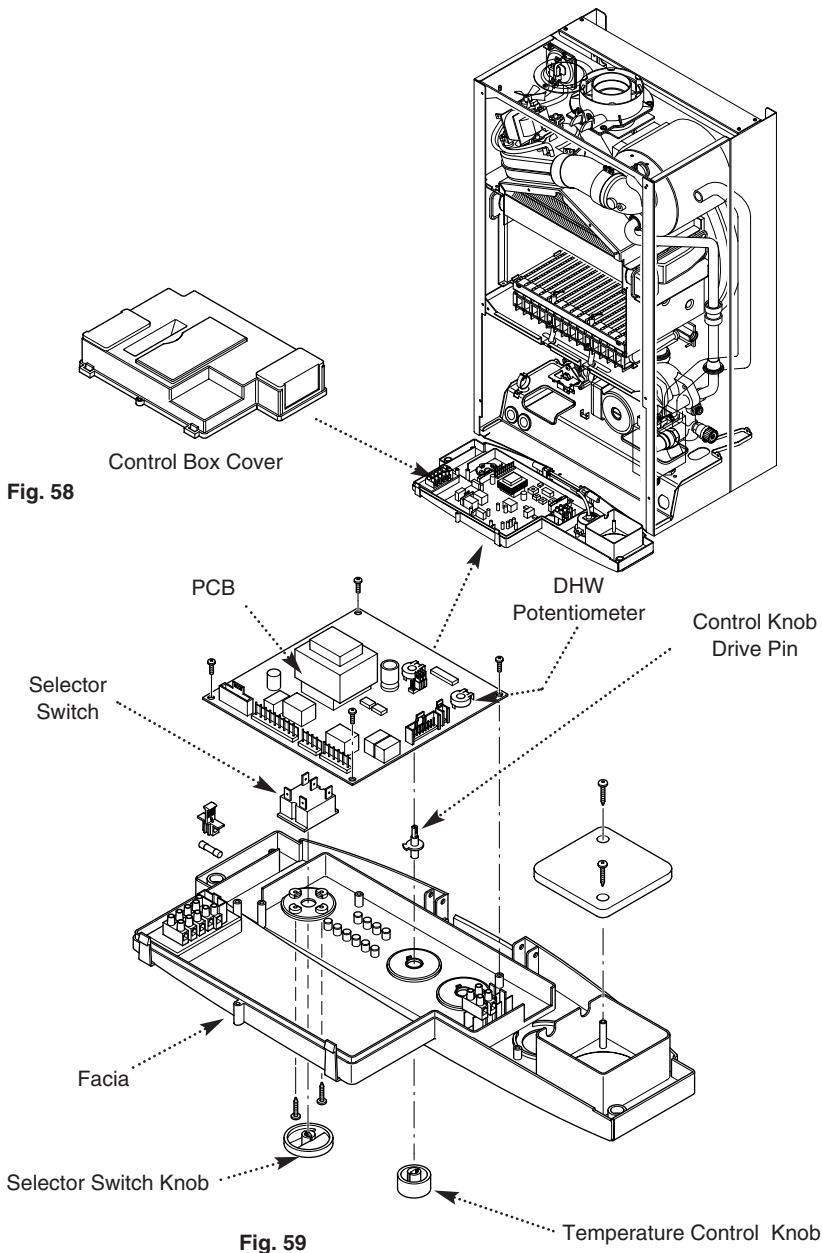

12.0 CHANGING COMPONENTS

12.20 Central Heating Differential Valve (Figs. 60 & 61)

1. Drain the primary circuit.
2. Undo the screw securing the microswitch to the differential valve. Allow the microswitch to rest to one side.
3. Undo the pressure gauge capillary nut and heating flow pipe nut from the valve.
4. Prise off the bypass connecting clips and disconnect the heating flow tap. Undo the screws securing the valve to the boiler bottom panel. Remove the valve.
5. Remove the screws securing the cover from the valve body. Examine the condition of the diaphragm, spring and pushrod, replacing as necessary.
6. If required the complete valve assembly can be replaced.
7. Examine the sealing washers and 'O' ring on the pipes and capillary, replacing as necessary.

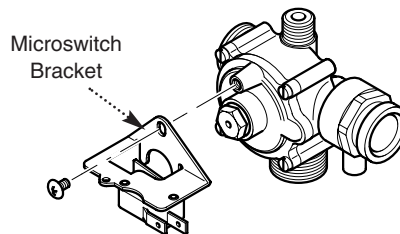
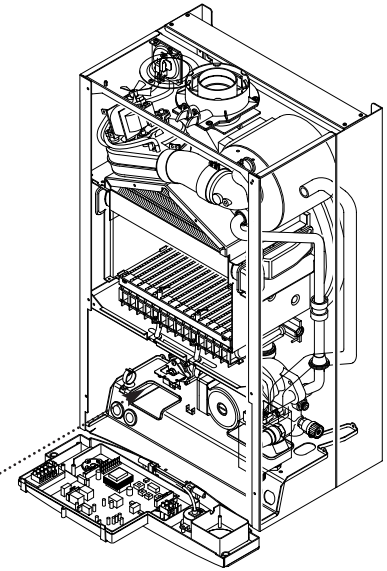

Fig. 60

12.21 Central Heating Differential Valve Microswitch (Fig. 61)

1. Remove the two wires from the microswitch.
2. Undo the screw securing the microswitch to the valve body.
3. Reassemble in reverse order.

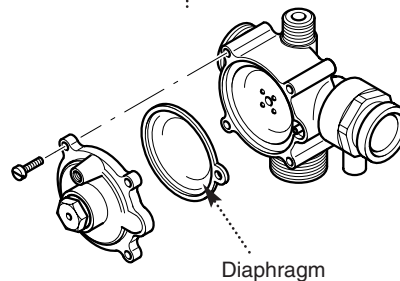

Fig. 61

12.22 Pressure Relief Valve (Fig. 62)

1. Drain the primary circuit.
2. Disconnect the discharge pipe from the valve. Using a suitable hexagon key undo the grub screw sufficiently to release the valve.
3. Note the orientation of the valve, rotate it and withdraw it from the manifold.
4. Fit the new valve and 'O' ring seal and set to the previously noted orientation. Reassemble in reverse order.

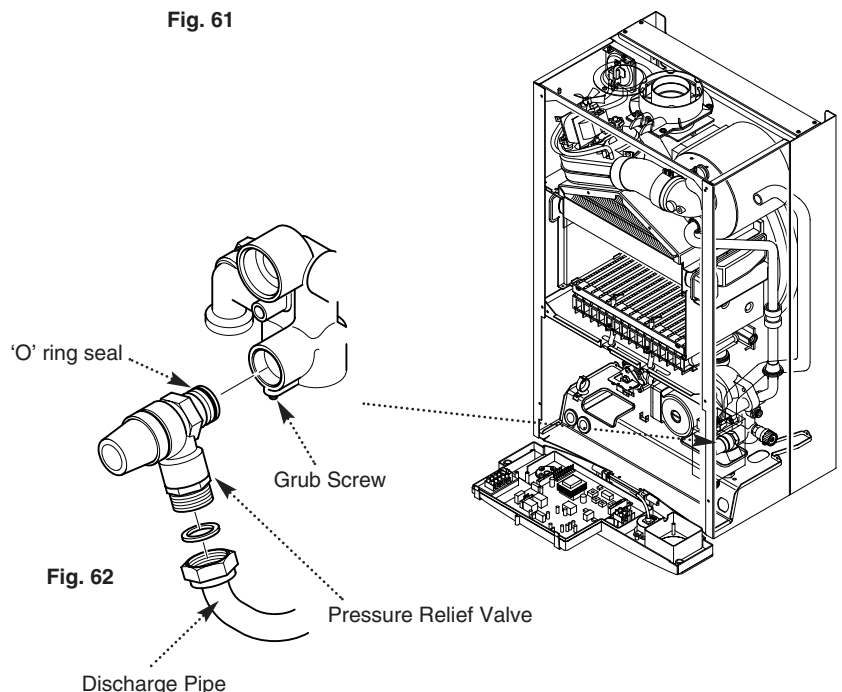

Fig. 62

12.0 CHANGING COMPONENTS

12.23 Secondary Heat Exchanger) (Fig. 63)

1. Drain the primary circuit
2. Undo the four screws securing the right hand case panel. Remove the panel.
3. Prise the connecting clips from the heat exchanger return pipe and the boiler return pipe. Remove the pipes.
4. Slacken the screws on the left hand fan spigot outlet pipe clamp. Ease the clamp to the right.
5. Remove the nut securing the elbow to the secondary heat exchanger. Draw the elbow and outlet pipe forwards.
6. Remove the secondary heat exchanger from the outer drum by easing it forward.
7. Reassemble in reverse order of dismantling.

12.24 Flue Overheat Thermostat (Fig. 64)

NOTE: The flue overheat thermostat includes a reset button. Check that the thermostat will not reset before replacing.

1. Remove the fan spigot outlet pipe from the fan and elbow.
2. Pull the two wires off the terminals on the flue overheat thermostat. Unscrew the thermostat from the adaptor in the outlet elbow.
3. Reassemble in reverse order of dismantling.

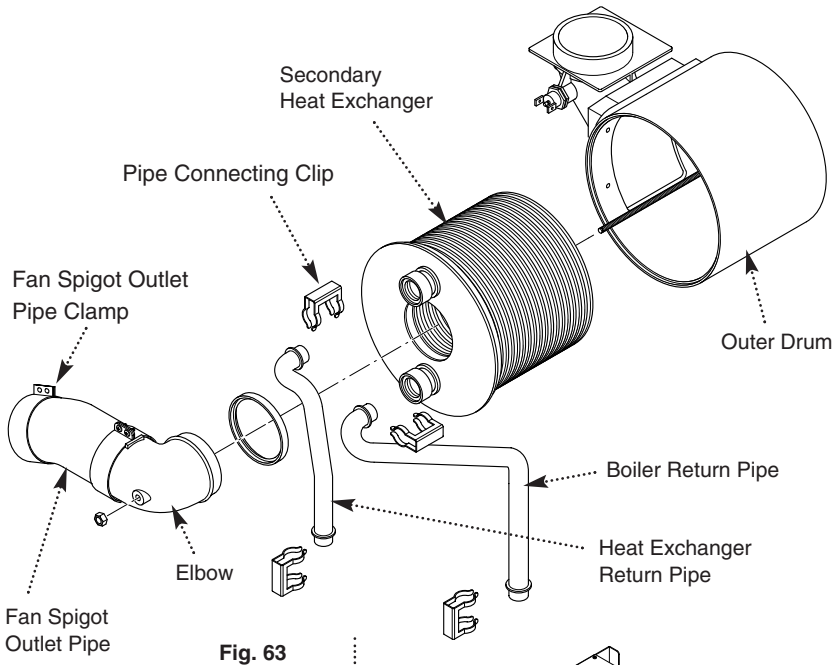
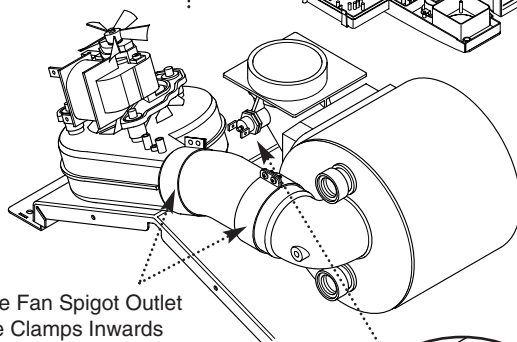
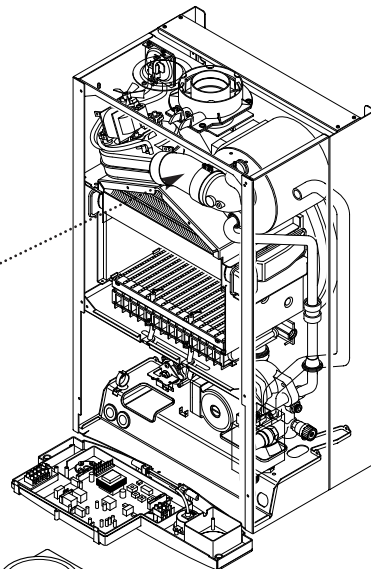

Fig. 63



28 model

Fan Spigot Outlet Pipe

Fig. 64

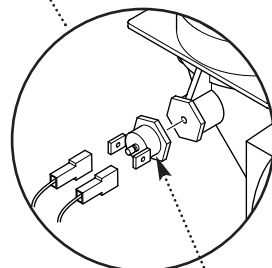

Overheat Thermostat

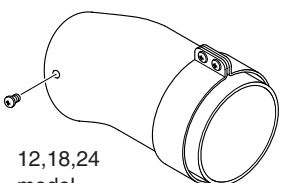

12,18,24
model

13.0 ELECTRICAL



13.1 Illustrated Wiring Diagram

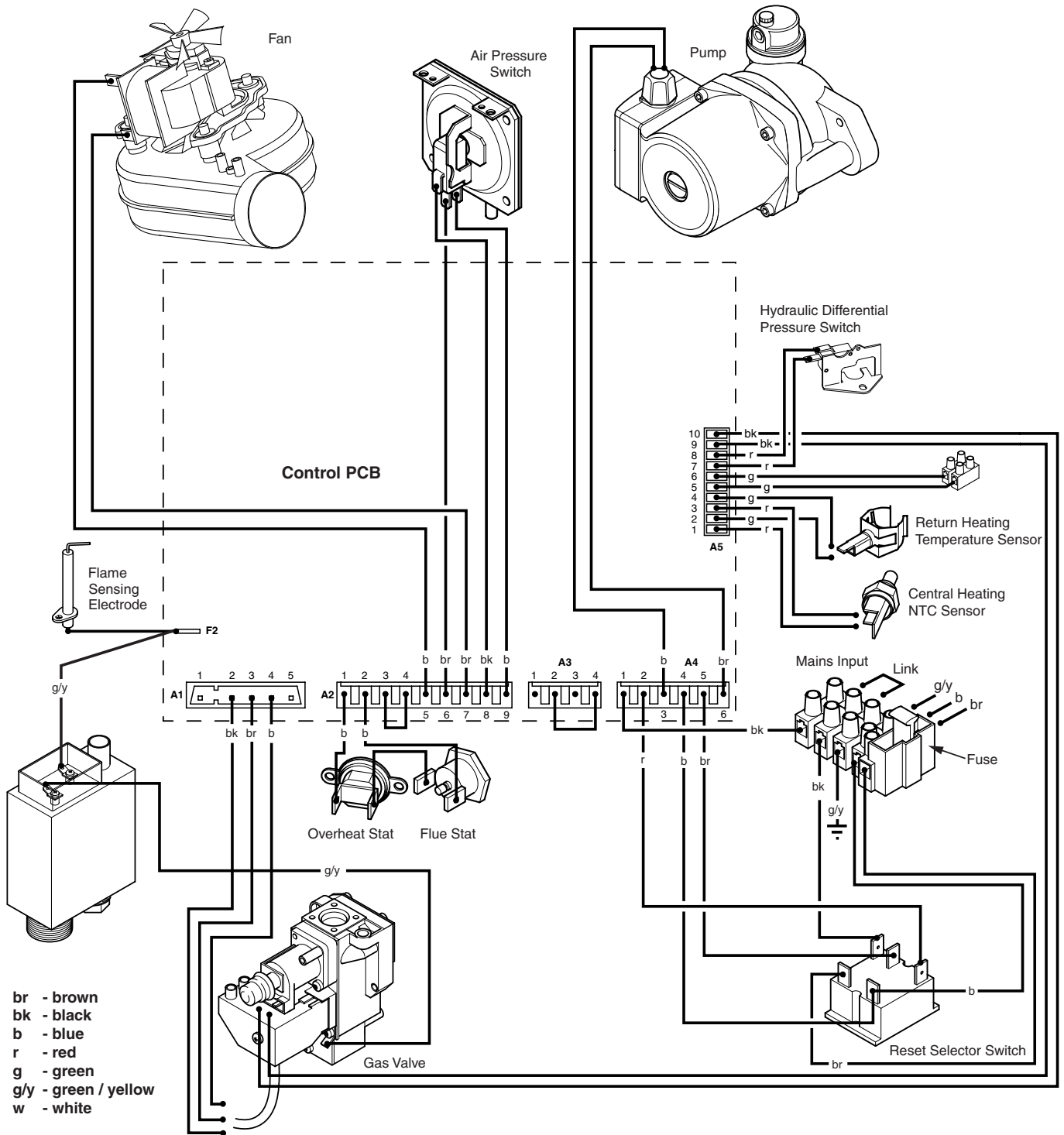

14.0 SHORT PARTS LIST

Key No.	G.C. No.	Description	Manufacturers Part No.
22		Fan (12,18 HE)	5113278
		Fan (24 HE)	5112627
		Fan (28 HE)	5112430
23		Pressure Switch (12 HE)	5113279
		Pressure Switch (18 HE)	5113280
		Pressure Switch (24,28 HE)	248466
32		Heat Exchanger (12,18 HE)	5113284
		Heat Exchanger (24,28 HE)	5112431
41		Burner (12 HE)	5113285
		Burner (18 HE)	5113286
		Burner (24,28 HE)	5112770
44		Injector 1.18 (12,18,24 HE)	247439
		Injector 1.25 (28 HE)	5112376
59	E66 408	Electrode Lead	248037
63	E66 411	Spark or Sensing Electrode	247384
72	E66 539	Pump	248042
102		Hydraulic Outlet Assy	248490
131	342 571	Temperature Sensor	247394
135	E66 439	Safety Thermostat	248079
140		Gas Valve	5107339
154		PCB	5112380
169	E66 453	Pressure Gauge	248090
528		Return Heating Temperature Sensor	248497
371		Igniter/Gas Valve Cable	5112385
A		Flue Overheat Thermostat	5112395

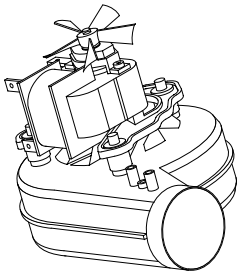

22

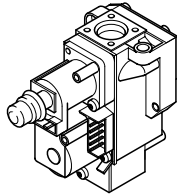

140



44

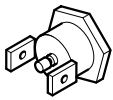

A

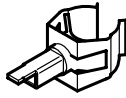

528



131

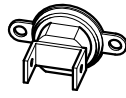

135

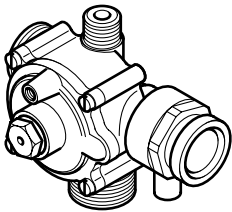

102

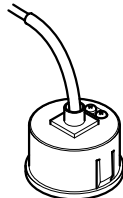

169

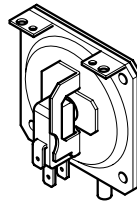

23

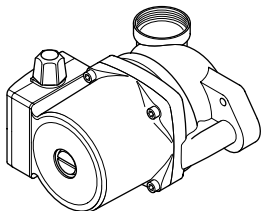

72

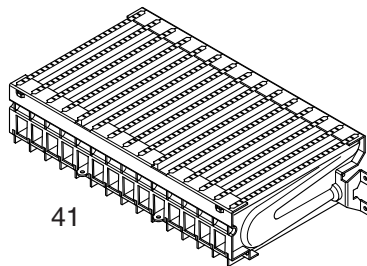

41

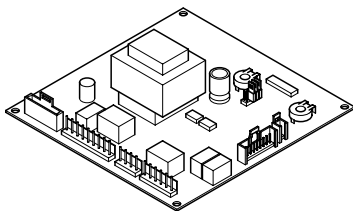

154

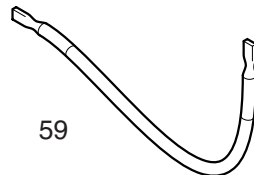

59

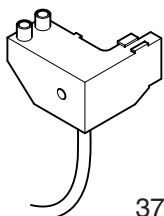

371

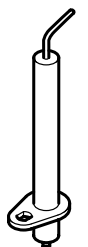

63

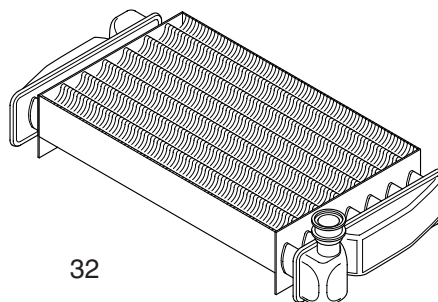

32

Carry out initial fault finding checks

1. Check that gas, water and electrical supplies are available at the boiler. Electrical supply = 230V ~ 50 Hz. CH water system pressurised to 0.5 bar when the boiler is cold. The preferred minimum gas pressure is 19.5mbar (natural gas), or 36mbar (propane).
2. Carry out electrical system checks, i.e. Ground Continuity, Resistance to Ground, Short Circuit and Polarity with a suitable meter. **NOTE:** These checks must be repeated after any servicing or fault finding.
3. Ensure all external controls are calling for heat and check all external and internal fuses. Before any servicing or replacement of parts ensure the gas and electrical supplies are isolated.

Refer to Section 13.0 "Illustrated Wiring Diagram" for position of numbered terminals
Central Heating - Follow operational sequence

NOTE: When instructed to turn the selector to the reset position turn the selector switch fully anticlockwise against the spring pressure to the 'Reset' position and hold for 2 seconds to reset the boiler.

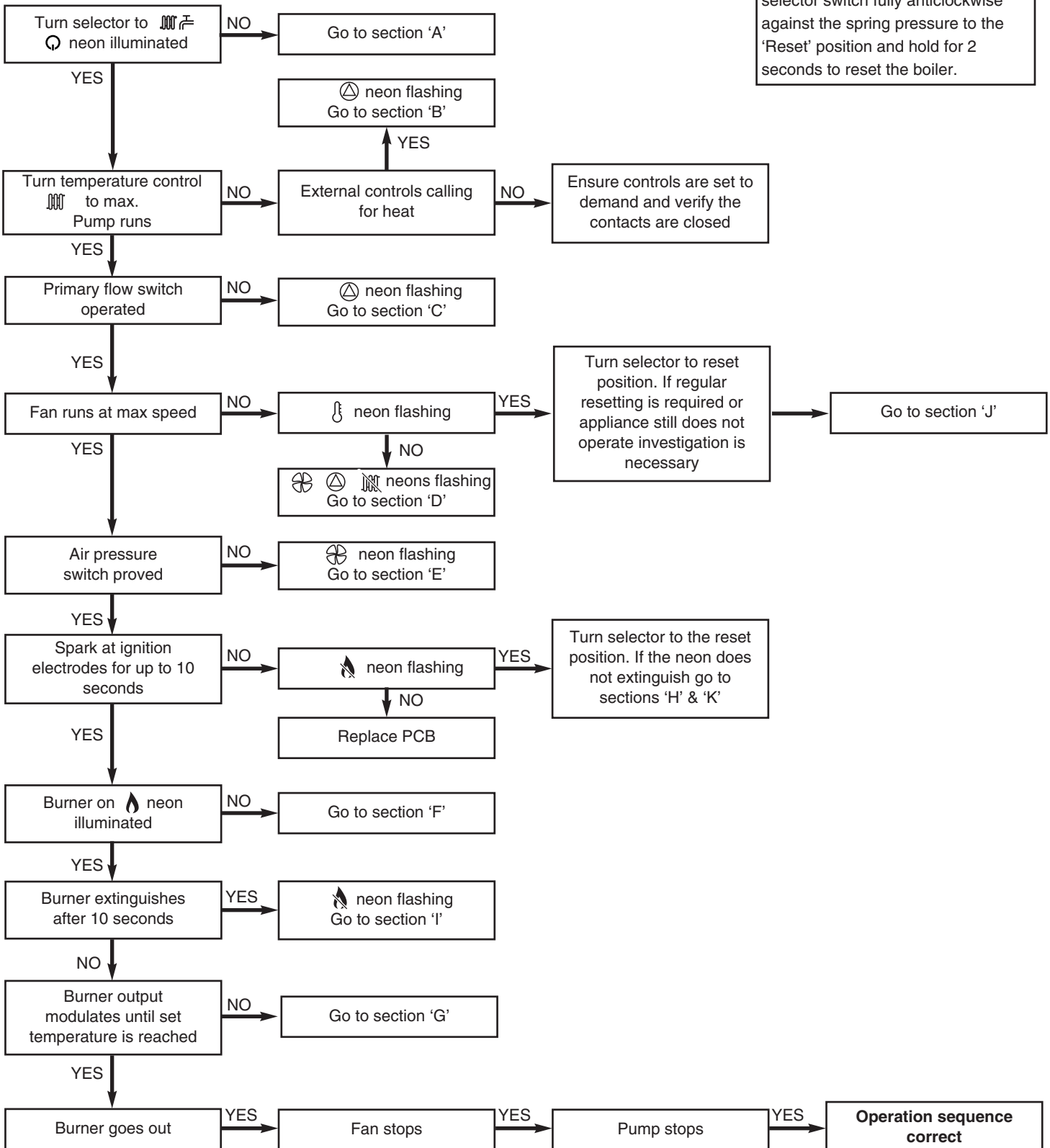

Fault Finding Solutions Sections A to E

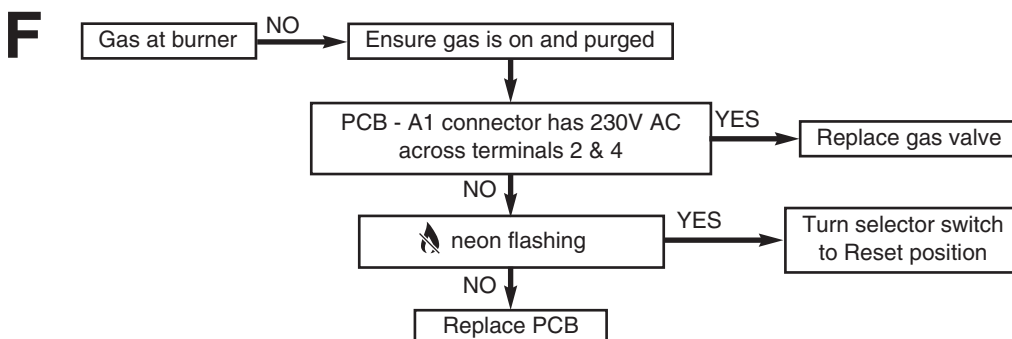
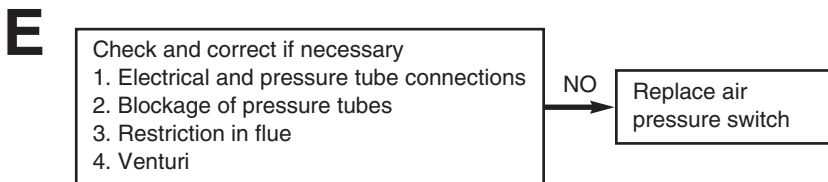
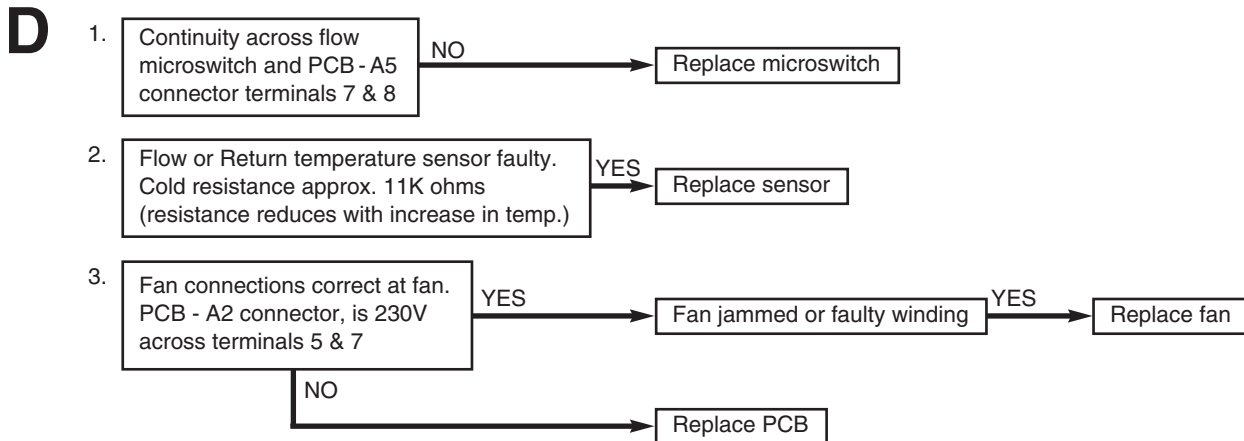
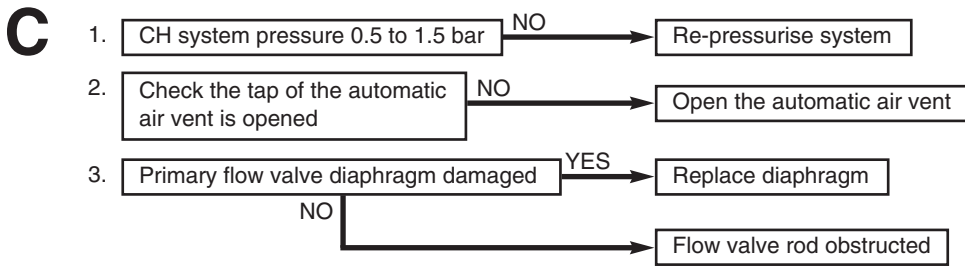
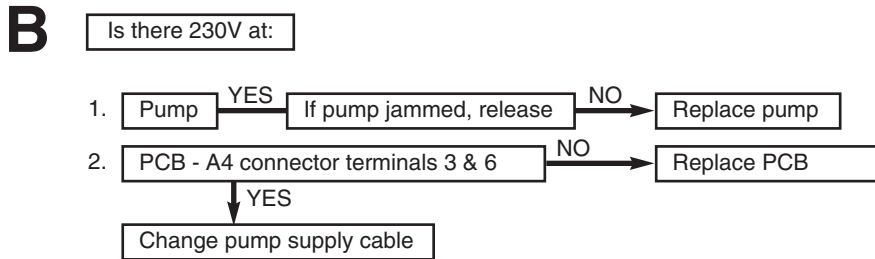
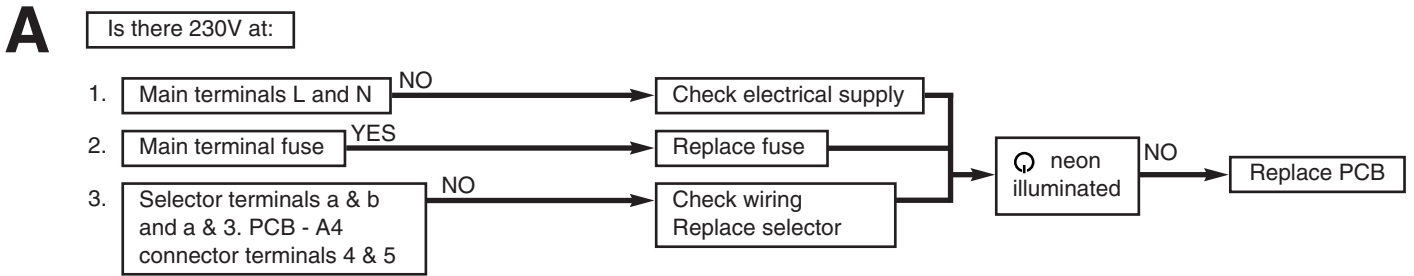

G

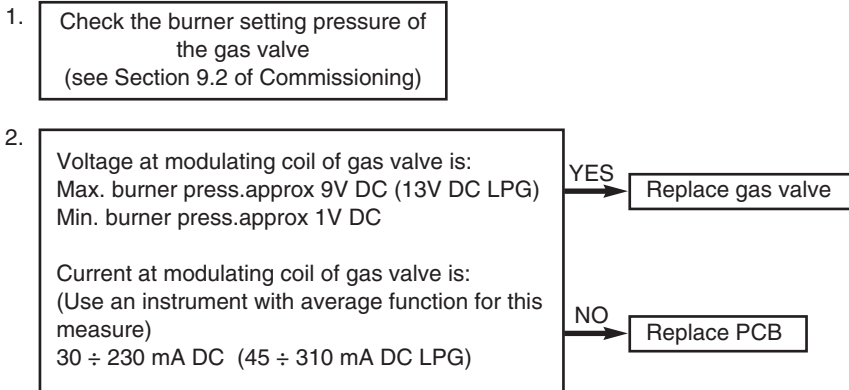

H

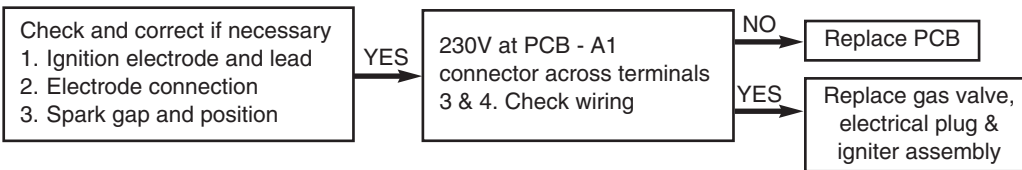

I

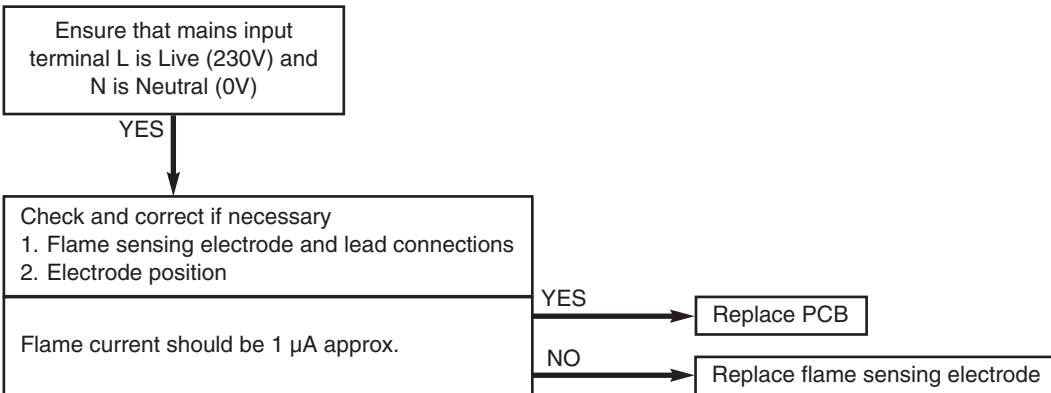

J

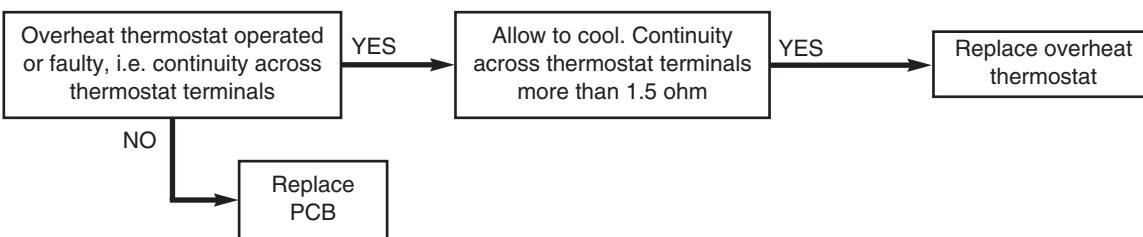

K

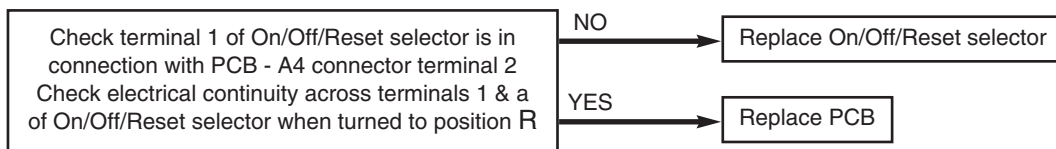

L

If checks in section I are completed successfully, blockage of the condensate drain or trap may have occurred

M

If checks in section J are completed successfully, the flue overheat thermostat may have operated. Press the reset button on the flue overheat thermostat. If the boiler does not relight or repeatedly cuts out. Check the operation of the flue system or replace the flue overheat thermostat



GAS BOILER COMMISSIONING CHECKLIST

BOILER SERIAL No. _____ NOTIFICATION No. _____

CONTROLS To comply with the Building Regulations, each section must have a tick in one or other of the boxes

TIME & TEMPERATURE CONTROL TO HEATING	ROOM T/STAT & PROGRAMMER/TIMER <input type="checkbox"/>	PROGRAMMABLE ROOMSTAT <input type="checkbox"/>
TIME & TEMPERATURE CONTROL TO HOT WATER	CYLINDER T/STAT & PROGRAMMER/TIMER <input type="checkbox"/>	COMBI BOILER <input type="checkbox"/>
HEATING ZONE VALVES	FITTED <input type="checkbox"/>	NOT REQUIRED <input type="checkbox"/>
HOT WATER ZONE VALVES	FITTED <input type="checkbox"/>	NOT REQUIRED <input type="checkbox"/>
THERMOSTATIC RADIATOR VALVES	FITTED <input type="checkbox"/>	
AUTOMATIC BYPASS TO SYSTEM	FITTED <input type="checkbox"/>	NOT REQUIRED <input type="checkbox"/>

FOR ALL BOILERS CONFIRM THE FOLLOWING

THE SYSTEM HAS BEEN FLUSHED IN ACCORDANCE WITH THE BOILER MANUFACTURER'S INSTRUCTIONS?

THE SYSTEM CLEANER USED _____

THE INHIBITOR USED _____

FOR THE CENTRAL HEATING MODE, MEASURE & RECORD

GAS RATE _____ m³/hr _____ ft³/hr

BURNER OPERATING PRESSURE (IF APPLICABLE) N/A _____ mbar

CENTRAL HEATING FLOW TEMPERATURE _____ °C

CENTRAL HEATING RETURN TEMPERATURE _____ °C

FOR COMBINATION BOILERS ONLY

HAS A WATER SCALE REDUCER BEEN FITTED? YES NO

WHAT TYPE OF SCALE REDUCER HAS BEEN FITTED? _____

FOR THE DOMESTIC HOT WATER MODE, MEASURE & RECORD

GAS RATE _____ m³/hr _____ ft³/hr

MAXIMUM BURNER OPERATING PRESSURE (IF APPLICABLE) N/A _____ mbar

COLD WATER INLET TEMPERATURE _____ °C

HOT WATER OUTLET TEMPERATURE _____ °C

WATER FLOW RATE _____ lts/min

FOR CONDENSING BOILERS ONLY CONFIRM THE FOLLOWING

THE CONDENSATE DRAIN HAS BEEN INSTALLED IN ACCORDANCE WITH THE MANUFACTURER'S INSTRUCTIONS? YES

FOR ALL INSTALLATIONS CONFIRM THE FOLLOWING

THE HEATING AND HOT WATER SYSTEM COMPLIES WITH CURRENT BUILDING REGULATIONS

THE APPLIANCE AND ASSOCIATED EQUIPMENT HAS BEEN INSTALLED AND COMMISSIONED IN ACCORDANCE WITH THE MANUFACTURER'S INSTRUCTIONS

IF REQUIRED BY THE MANUFACTURER, HAVE YOU RECORDED A CO/CO₂ RATIO READING? N/A YES _____ CO/CO₂ RATIO

THE OPERATION OF THE APPLIANCE AND SYSTEM CONTROLS HAVE BEEN DEMONSTRATED TO THE CUSTOMER

THE MANUFACTURER'S LITERATURE HAS BEEN LEFT WITH THE CUSTOMER

COMMISSIONING ENG'S NAME PRINT _____ CORGI ID No. _____

SIGN _____ DATE _____

SERVICE INTERVAL RECORD

It is recommended that your heating system is serviced regularly and that you complete the appropriate Service Interval Record Below.

Service Provider. Before completing the appropriate Service Interval Record below, please ensure you have carried out the service as described in the boiler manufacturer's instructions. Always use the manufacturer's specified spare part when replacing all controls

SERVICE 1 DATE

ENGINEER NAME

COMPANY NAME

TEL No.

CORGI ID CARD SERIAL No.

COMMENTS

SIGNATURE

SERVICE 2 DATE

ENGINEER NAME

COMPANY NAME

TEL No.

CORGI ID CARD SERIAL No.

COMMENTS

SIGNATURE

SERVICE 3 DATE

ENGINEER NAME

COMPANY NAME

TEL No.

CORGI ID CARD SERIAL No.

COMMENTS

SIGNATURE

SERVICE 4 DATE

ENGINEER NAME

COMPANY NAME

TEL No.

CORGI ID CARD SERIAL No.

COMMENTS

SIGNATURE

SERVICE 5 DATE

ENGINEER NAME

COMPANY NAME

TEL No.

CORGI ID CARD SERIAL No.

COMMENTS

SIGNATURE

SERVICE 6 DATE

ENGINEER NAME

COMPANY NAME

TEL No.

CORGI ID CARD SERIAL No.

COMMENTS

SIGNATURE

SERVICE 7 DATE

ENGINEER NAME

COMPANY NAME

TEL No.

CORGI ID CARD SERIAL No.

COMMENTS

SIGNATURE

SERVICE 8 DATE

ENGINEER NAME

COMPANY NAME

TEL No.

CORGI ID CARD SERIAL No.

COMMENTS

SIGNATURE

SERVICE 9 DATE

ENGINEER NAME

COMPANY NAME

TEL No.

CORGI ID CARD SERIAL No.

COMMENTS

SIGNATURE

SERVICE 10 DATE

ENGINEER NAME

COMPANY NAME

TEL No.

CORGI ID CARD SERIAL No.

COMMENTS

SIGNATURE

General Enquiries (GB)

Tel. **08706 060 780**

Technical (GB)

Tel. **08706 049 049**

Service (GB)

Tel. **08706 096 096**

Fax. **01926 410 006**

Literature Request (GB)

Tel. **08706 060 623**

Technical (IE)

Tel. **1850 560570**

All descriptions and illustrations provided in this leaflet have been carefully prepared but we reserve the right to make changes and improvements in our products which may affect the accuracy of the information contained in this leaflet. All goods are sold subject to our standard Conditions of Sale which are available on request.

BAXI POTTERTON

A Trading Division of Baxi Heating UK Ltd

Brownedge Road Bamber Bridge Preston Lancashire PR5 6UP

After Sales Service 08706 096 096 Technical Enquiries 08706 049 049

Website www.potterton.co.uk