



Installation Instructions and User Guide

**NEWTEAM 1000-XT
THERMOSTATIC POWER SHOWER**

**IN THE EVENT OF ANY QUERY PLEASE CONTACT
THE NEWTEAM CUSTOMER HELPLINE**

Tel : 01536 264 012

NewTeam

**PLEASE KEEP THIS BOOKLET
FOR FUTURE REFERENCE**

**DEAR INSTALLER WHEN YOU HAVE READ THESE INSTRUCTIONS
PLEASE ENSURE YOU LEAVE THEM WITH THE USER**

NewTeam 1000-XT

- Integral pump
- Push-fit fittings
- 3 spray massage handset with rub-clean feature
- Thermostatic temperature control
- Push button stop/start
- BEAB approval of safety

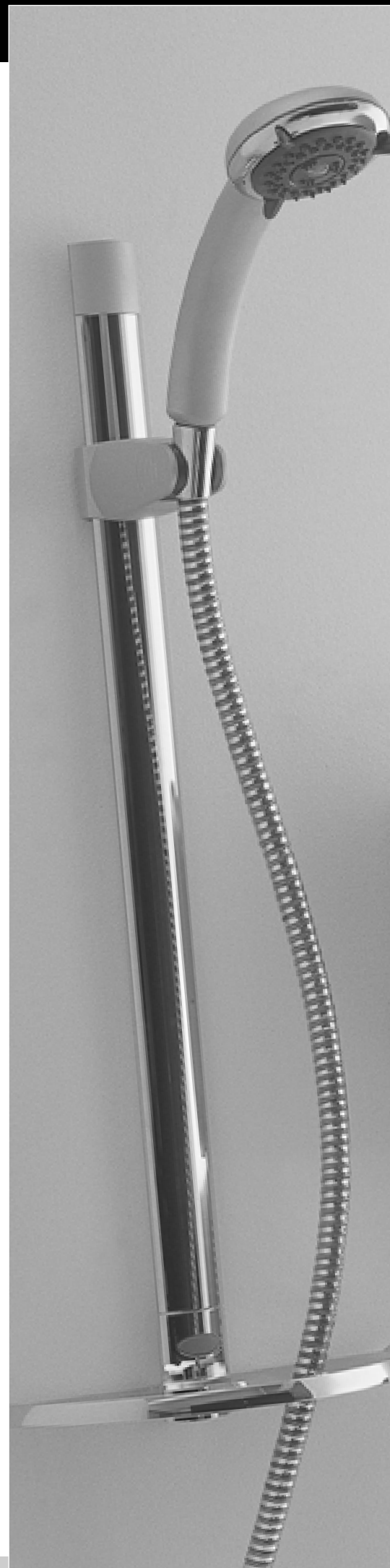
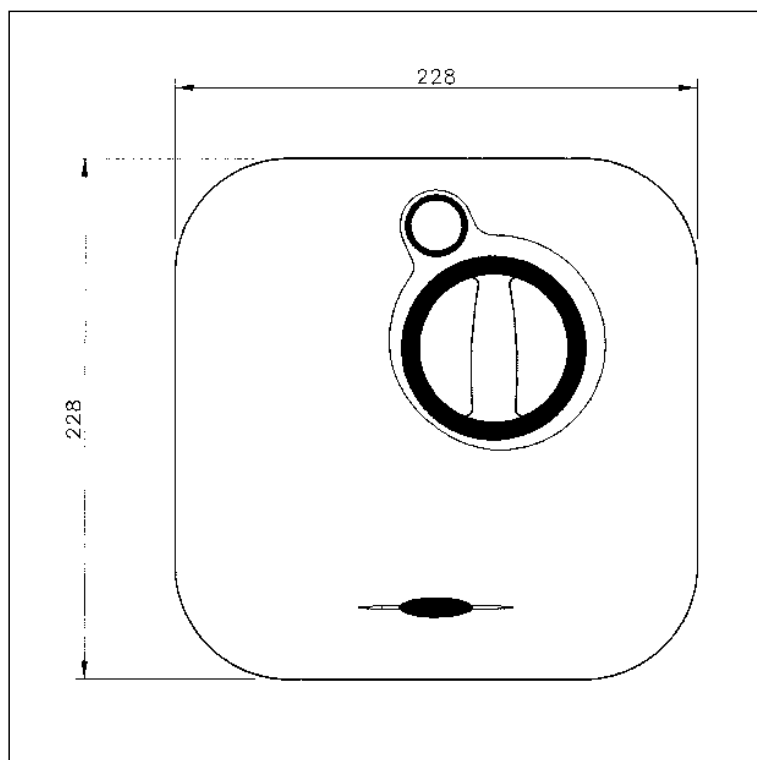

Contents

Installation and Operating Instructions for NewTeam Power Shower

● 1000-XT

Please read this booklet carefully and ensure a competent person undertakes the installation.

Note: Following the headings in sequence will guide you through the installation and operation of your NewTeam 1000-XT Power Shower.

	Pages
PLANNING YOUR INSTALLATION	3
• Plumbing	
• Electrics	
FITTING YOUR SHOWER	4-6
• General	
• Plumbing Connections	
• The Unit	
• Water/Electrical Connections	
• Riser Rail	
COMMISSIONING	7
TEMPERATURE ADJUSTMENT	7
USER INSTRUCTIONS	8
TROUBLE SHOOTING	8
SPARE PARTS LISTING	9
INSTALLER NOTES	10
GUARANTEE	13

Refer to back cover for Guarantee, Customer Service and Replacement Parts Policy. In the event of any query regarding installation please contact the NewTeam Customer Service Department

Tel: 01536 264 012 • Fax: 01536 409 201

E-mail: service@newteam.co.uk • E-mail: spares@newteam.co.uk

In line with our policy of continual product development the specifications may be varied and product design altered. We reserve the right to depart from the details given in this manual without prior notice.



Plumbing

Under no circumstances should the unit be connected directly to the mains cold water supply, or to a combination boiler, or pressurised hot water system.

For correct operation of the NewTeam 1000-XT power shower, both hot and cold water supplies must be gravity fed, at nominally equal pressures, from a cold water storage tank, and a hot water storage cylinder.

We recommend a minimum of 115 litres (25 gallon actual) of cold water supplied by a storage tank. Please ensure compliance with all Water Regulations. **Under no circumstances must the Power Shower be connected to the mains cold water supply.**

Please ensure maximum supply head of 10 metres, minimum 75mm.

It is recommended that the hot water supply is at a temperature of 60°C, in line with British Standard 6700, British Water Regulations, and Plumbing Code of Practice.

Do not use jointing compounds when connecting, and do not solder within 300mm of the unit.

Before proceeding with the installation of this unit, check that your site requirements allow the top of the unit to be a minimum of 75mm below the bottom of the cold water storage tank.

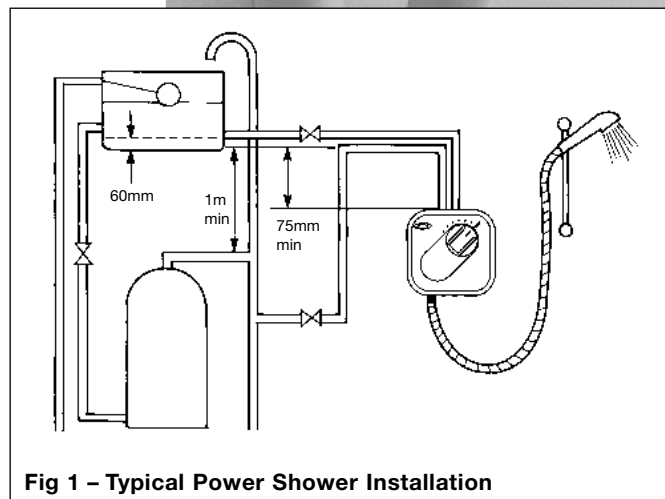

Fig 1 – Typical Power Shower Installation

Electrics

WARNING: THIS APPLIANCE MUST BE EARTHED.

All electrical wiring for the shower must comply with the current I.E.E Regulations which includes earth-cross bonding to all metal pipework.

IMPORTANT:

All plumbing should be completed before final electrical connections are made.

The shower must be connected to a 230/240 volt A.C electrical supply from a 13-amp ring main, via a fused double pole switch with at least 3mm contact separation. The switch is to be clearly identifiable, a minimum distance of 2.5m from a fixed tap or shower, i.e. mounted in an adjacent room or via a ceiling-type pull cord switch. The unit should be fused at no more than 3 amps.

This appliance must be earthed, and all associated metal pipework earth crossbonded in line with current I.E.E regulations.

As the colours of the wires in the cable (not supplied) used to connect to this appliance may not correspond with the coloured markings identifying the terminals in your switch, please follow the procedure below:

Please use the cable entry point provided. Failure to comply will eliminate any BEAB approval.

Procedure:

- The wire, which is coloured Blue or Black, must be connected to the terminal that is marked with the letter N.
- The wire, which is coloured Brown or Red, must be connected to the terminal that is marked with the letter L.
- The wire which is coloured Yellow/Green must be connected to the terminal which is marked with the earth symbol \oplus .
- The installation and wiring must comply with I.E.E regulations.

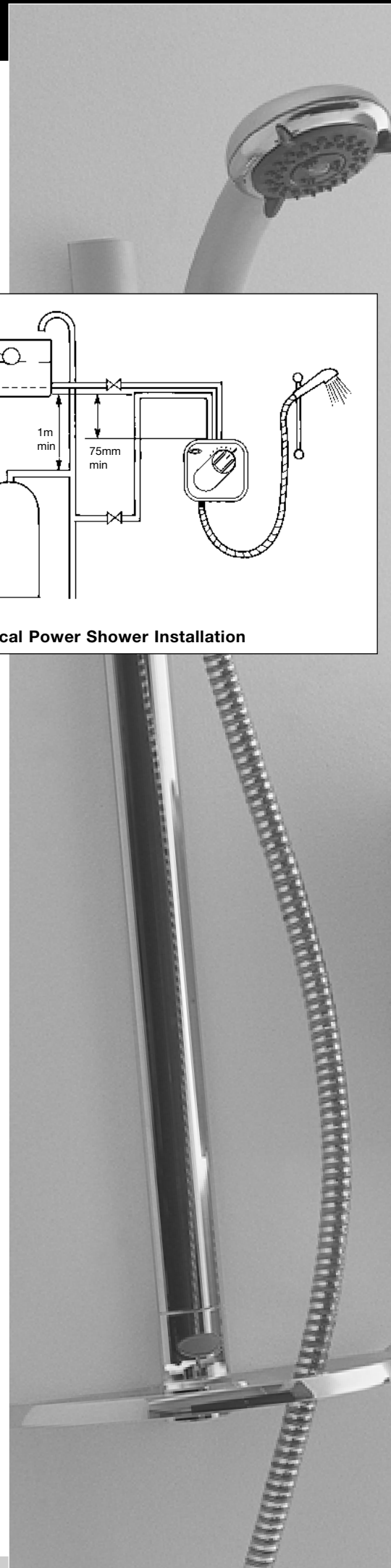

General

In addition to the recommendation on 'Planning your Installation' please take note of the following:

- All plumbing should be completed before any electrical connections are undertaken.
- The unit can be connected to a combination cylinder system providing it has a cold water storage capacity of 115 litres (25 gallons actual).
- When connecting pipework avoid using elbows: sweep or formed bends will ensure optimum performance.
- Do not solder within 300mm of the unit.
- Do not run pump dry this will damage the internal seal and invalidate the warranty.
- All pipework to and from the unit should be a minimum of 15mm. Non-restrictive isolating valves must be fitted on hot and cold supply pipes.
- Do not position unit in areas subjected to freezing conditions.
- The temperature of your stored water must not exceed 65°C. A stored water temperature of 60°C is considered sufficient to meet all normal requirements in line with the British Standard 6700.

WARNING – ALL CONNECTING PIPEWORK SHOULD BE EARTHED

Procedure - Plumbing Connections: Fig 1.

1. Isolate mains water and electrical supplies.
2. To empty the pipework open the hot and cold water taps.
3. Make your connection into the hot water supply pipe from the cylinder, ensuring that it is the first draw-off (below the expansion pipe tee) to minimise the effects of water draw offs elsewhere in the house, and a minimum of 1 metre from the base of the cold storage tank and the expansion tee.
4. If this is not possible, a direct connection must be made from the hot water cylinder with a cylinder flange, Fig 2.
5. The cold water supply should be taken directly from the cold storage tank, and must be positioned 60mm below the cold feed connection to the hot water cylinder. This should not be directly beneath the ball valve as aeration of the water going to the shower could cause pump damage.
6. Run hot and cold pipework to the unit position.

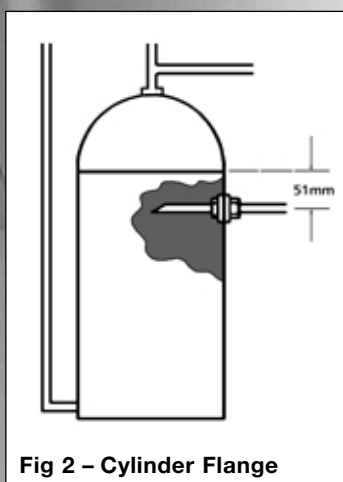

Fig 2 – Cylinder Flange

The Unit

We recommend that the unit is fitted at chest height, and set to one side of the intended riser rail position, ensuring that the top of the unit is at least 75mm below the base of the cold water tank.

IMPORTANT:

- The unit must be fitted on the finished tiled surface.
- Do not seal the edge of the unit to the tiled surface with any sealant, as the gap below the back of the unit and the tiles is needed for ventilation.
- The outlet connection must be positioned at the bottom of the unit.

Water/Electrical Connections

WARNING:

Do not fit fuse or switch on mains electrical supply until all plumbing work is completed. Connecting pipework can feed from above or below the unit, or straight through the wall at nominal centres of 40mm.

Top Feed = Hot on the right /cold on the left

Bottom Feed = Hot on the left/cold on the right

Back Feed = Hot on the bottom/cold on the top

Procedure:

- The integral fittings on the valve are of the self-seal push-fit type. All burrs and rough edges must be removed from the end of the tube. Where chrome plated tube is used, roughen or remove the first 25mm of plating
- The inlet elbows supplied are of a standard length, in some cases these will need to be shortened for correct installation, please refer to the tables for correct measurements.

1000-XT

1. Flush out pipework before installing the unit.
2. Cut the inlet elbows to the required length, please refer to table below.
3. Locate the inlet elbows into the mixer valve inlets by pushing firmly through rubber grommets until pipe stop is felt.
4. Hold the unit on the wall and mark the pipe work to the appropriate length.
5. Cut the pipes and remove all burrs. Push the unit and elbows firmly onto the pipes until the stop is felt.
6. Mark the fixing points for the unit, Fig 3.
7. Release unit from pipes by pressing the collets on the elbow fittings, and pulling the unit off the pipework, Fig 4.
8. Drill the wall and insert the appropriate wall fixings.
9. Bring a supply cable (to conform to I.E.E regulations) from the switch to the unit position. The cable can enter the unit from the rear, or via channels in the base of the unit, and the bottom or the right hand side.
10. Feed the supply cable in to the unit but do not connect.
11. Refit unit to pipes and secure to wall using 32mm x No.8 screws provided.
12. Connect the supply cables into the appropriate terminals (marked N, L and ⊕ symbol) on the terminal block, and secure into position with the cable clamp.
13. Do not fit the front cover at this stage. Refer to the commissioning procedure on page 7.

Note: If the electrical supply cable is concealed in the wall ensure that it avoids the unit's fixing points so that fixing screws do not pierce the cable.

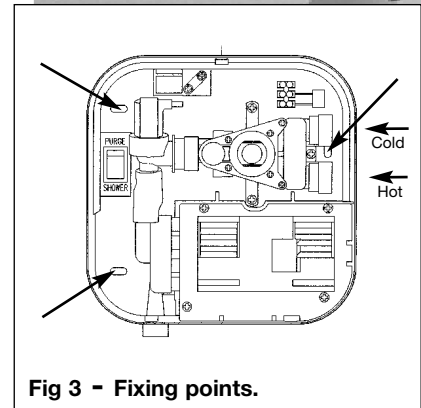

Fig 3 - Fixing points.

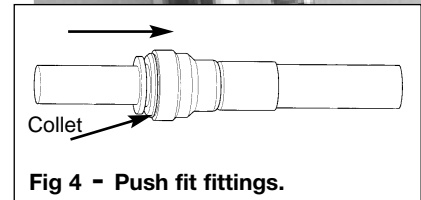

Fig 4 - Push fit fittings.

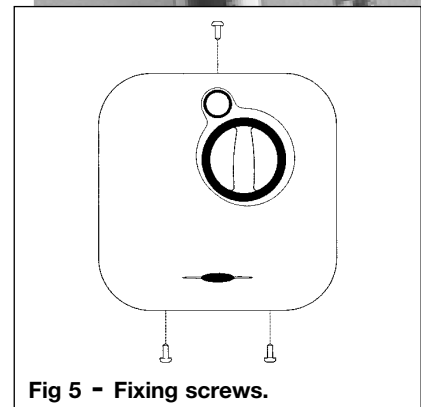





Fig 5 - Fixing screws.

		Inlet elbows	
Short Inlet Elbow Top/Bottom Feed	63mm		
Long Inlet Elbow Top/Bottom Feed	86mm		
Both Inlet Elbow Back Feed	63mm		Measurements given in the table are to be taken from these points

Spirit Rail Kit

Before proceeding with fitting the rail, identify each of the items supplied using the illustration.

The slider need not be removed from the rail during fitting. The top of the slider has a smooth profile, whereas the underside has a recess revealing the grooves on the handset holder.

No	Part Description
1	Rail end cap
2	Spirit level
3-4	Rail with slider attached
5	Soap Dish
6	Screw cap
7	Soap dish fixing screw
	Rail fixing screws & wall plugs

Fit the soap dish onto the bottom end of the rail and secure using the small screw from the kit.

Position the rail on the wall, bearing in mind the heights of people likely to use the shower, and the length of the hose when connected to the shower and passed through the retaining hole in the soap dish. Mark the wall to indicate the upper fixing screw position. Screw centres are 605 mm (approx. 23 - inches,) apart.

Drill the wall at the marked fixing position using a 6 mm drill, and loosely fix the rail end, checking that the rail is hanging vertically using the spirit level incorporated into the top end of the rail. The bubble should be exactly between the two lines on the spirit level body. Mark the position for the lower fixing screw, move the rail to one side, drill the wall, and fix the lower end of the rail.

Check that the rail is vertical and tighten both fixing screws.

Slide the end cap into position on the top end of the rail, and fit the screw cover into the recess in the soap dish.

When fitting the hose, it should pass through the larger hole of the soap dish.

Note: The hose nut, and not the handset handle, fits into the slider, and the slider moves more freely on the rail if gripped next to the rail, rather than at the handset.

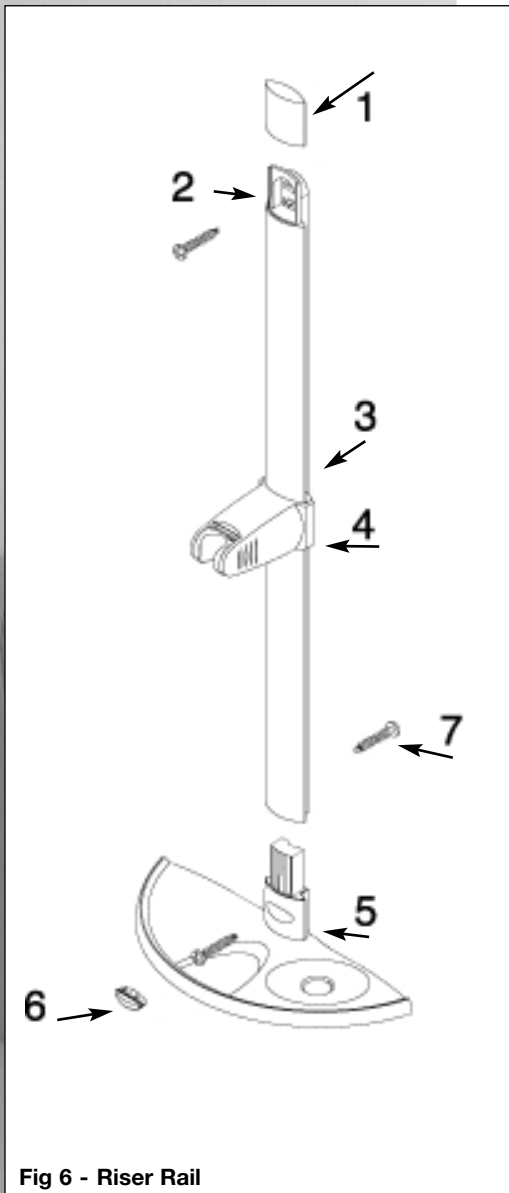

Fig 6 - Riser Rail

Commissioning

1. With the front cover removed ensure the black 'purge/shower' switch inside the base is switched to purge (see A, fig 7). This enables water to flow without the pump running which is necessary in the following commissioning process.
2. Fit the front cover and fix with fixing screws (see fig 5).
3. Push the temperature control knob onto the spindle with the marker pointing to the '12 o'clock' position.
4. Connect the shower hose to the unit but do not fit the handshower.
5. Turn on the hot and cold water isolating valves, and the electricity-isolating switch. Place the open end of the hose in the bath or shower tray.
6. Set the temperature control knob to fully cold (marker at '6 o'clock' position) and press the 'stop/start' button. The pump will not operate but water should run.
7. Cold water will flow from the hose, and you should allow this to continue for two minutes after which the control knob should be returned to the '12 o'clock' position. Allow the water to run for a few minutes to stabilise the hot water flow.
8. Turn off the electricity at the isolating switch and remove the knob and cover. Switch the black 'purge/shower' switch to shower and refit the cover and knob ensuring the marker on the knob points to the '12 o'clock' position.
9. Turn on the electricity at the isolating switch.
10. Pass the hose through the hole in the front of the soap dish and fit the handshower
11. Your shower is now ready to run. Press the stop/start button on the front cover to operate the shower, which will work as a power shower.
12. It is intended that with the temperature knob aligned to the '12 o'clock' position you should get a comfortable shower temperature. If however the shower is too hot or too cold remove the control knob and adjust the brass spindle anti-clockwise to increase temperature – clockwise to decrease. When the desired shower temperature is achieved replace the knob with the marker pointing to the '12 o'clock' position.

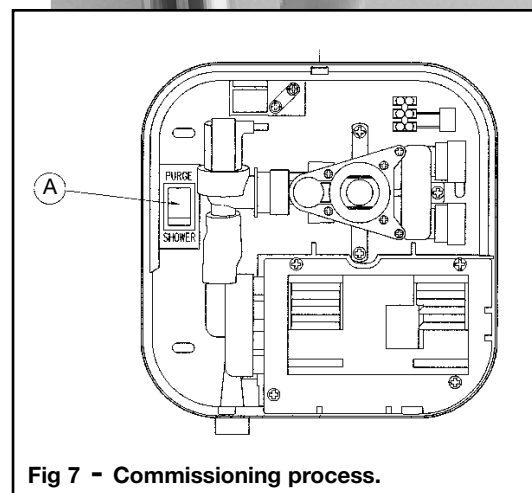

Fig 7 - Commissioning process.

Temperature Adjustment

The valve allows the maximum showering temperature to be set at a safe level, preventing accidental scalding. This setting should be made during commissioning and will require that the hot water cylinder is at its normal operating temperature.

IMPORTANT:

- The handset must be in the spray mode.
- We recommend the reading of User Instructions before proceeding further. This will familiarise you with the operation of the shower.

Procedure:

Turn the brass mixer valve spindle fully clockwise, and then anti-clockwise until the black line on the spindle is aligned with the groove on the mixer body, and fit the control knob in the fully cold position. Check that it is correctly fitted by turning fully clockwise to the stop, pull the knob off and check that the black line and groove are aligned. Adjust if necessary. This sets the shower temperature to 38-40°C, with the control knob pointing to '12 o'clock', if the stored hot water is at the recommended 60°C.

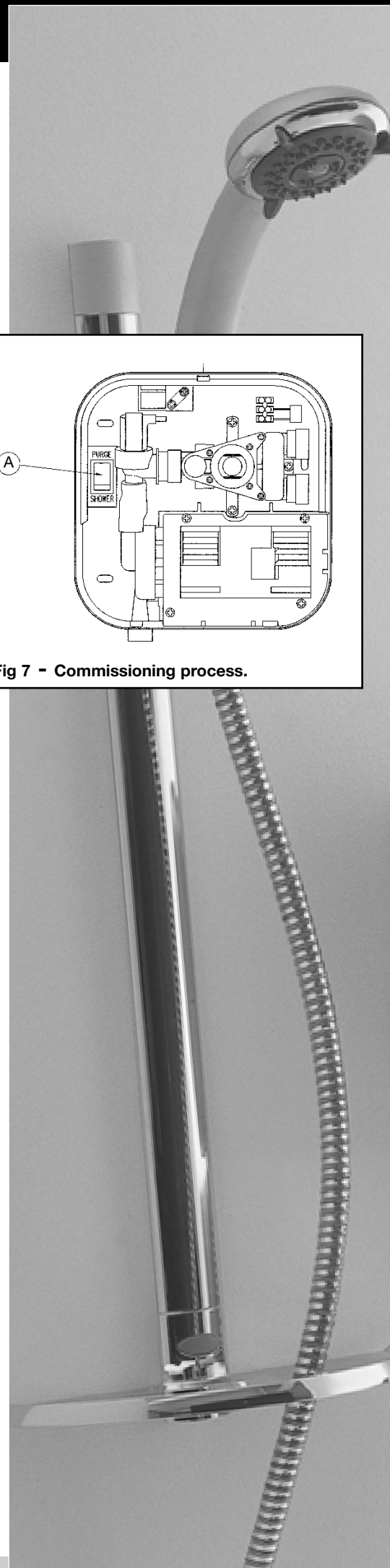

NewTeam 1000-XT

1. To operate the shower ensure the temperature control knob is set approximately to the '12 o'clock' position and press the stop/start button.
2. For a hotter shower turn the control knob anti-clockwise, for a cooler shower turn it clockwise.
3. The handset holder has a friction grip on the rail and simply slides up and down to adjust the height. The angle of the handset can also be adjusted.
4. The handshower has three shower modes, which are selected by rotating the bezel around the spray head.

Trouble shooting

Symptom	Likely Cause	Action/Remedy
Pump not operating but water is flowing	Purge/shower switch switched to purge	Isolate electrical supply, remove cover and switch to shower
Pump not operating and no water is flowing	No electricity supply to unit	Check all fuses and electrical supply
Pump operates but no water is flowing	No water supply to unit	Check isolating valves are turned on
		Check cold-water storage tank has not run dry
Poor performance	Restrictions in water supply	Check both hot and cold isolating valves are fully open
	Pump may have overheated	Allow unit to cool and retry
	Unit may be incorrectly installed	Check that the top of the shower unit is at least 75 mm below the base of the cold-water tank
If in doubt please call the NewTeam helpline: 01536 264012		



NewTeam 1000-XT

Item No.	Part No.	Description	Finish
1	SP-087-0603	Base assembly*#	White or matt chrome
2	SP-087-0604	Front cover*#	White or matt chrome
3	SP-087-0110	Pump unit	Not applicable
4	SP-087-0035	Motor cover	Not applicable
5	SP-087-0127	Pipe connection	Not applicable
6	SP-087-0230	Solenoid	Not applicable
7	SP-087-0014	Front cover screws*	Not applicable
8	SP-087-0129	Latching switch*	Not applicable
9	SP-086-0061	Long inlet elbow x 2*	Not applicable
10	SP-087-0154	Mixer valve assembly	Not applicable
11	SP-087-0505	Temperature control knob*#	White or matt chrome
12	SP-087-0514	Stop/start button*#	White or matt chrome
13	SP-087-0068	Pipe cover*#	White or matt chrome
14	SP-087-0211	Purge/shower rocker switch*	Not applicable
15	SP-280-0100	Spirit rail and slider assembly*#	White or matt chrome/chrome
16	SP-280-0033	Soap dish*#	White or chrome
17	SP-280-0024	Rail end cap*#	White or matt chrome
18	SP-285-0820	Hose*#	White or chrome
19	SP-168-0204	Zag Handshower*#	White or matt chrome

* Not shown # Please define colour

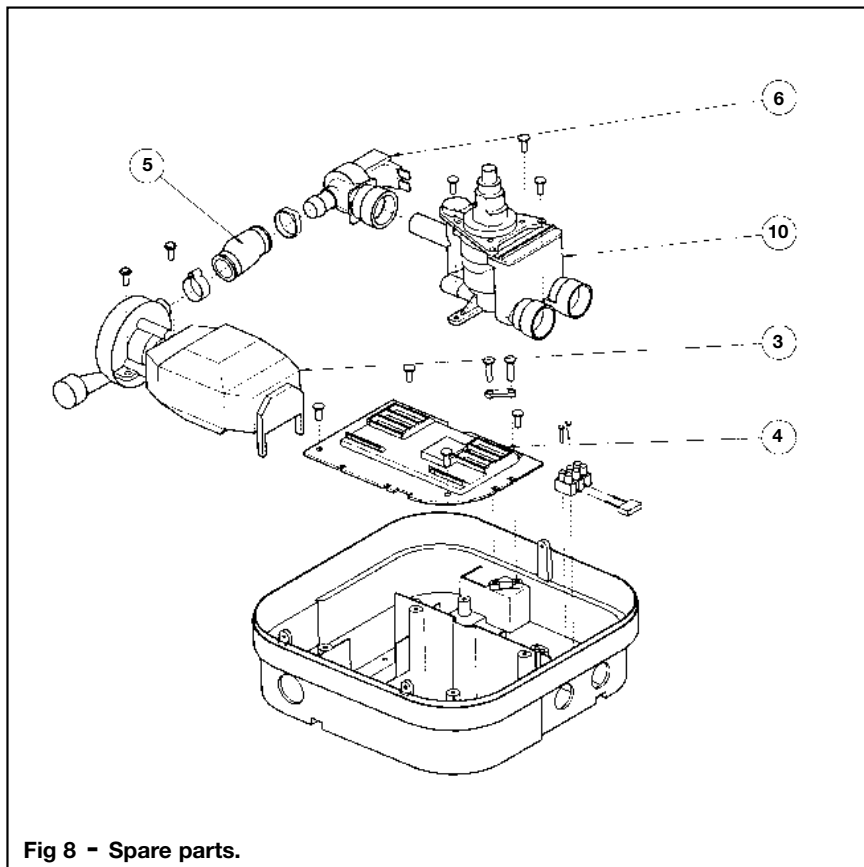
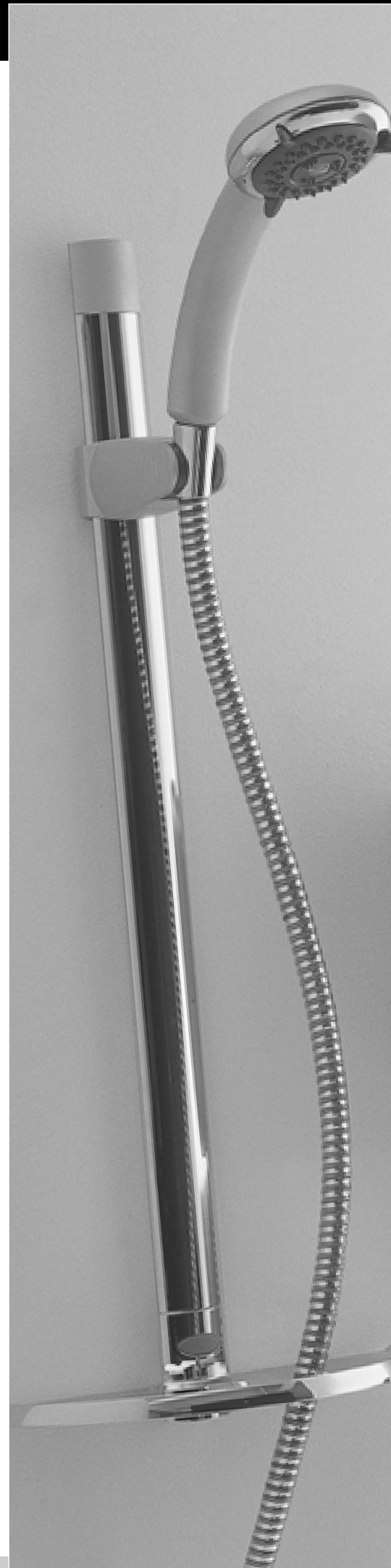
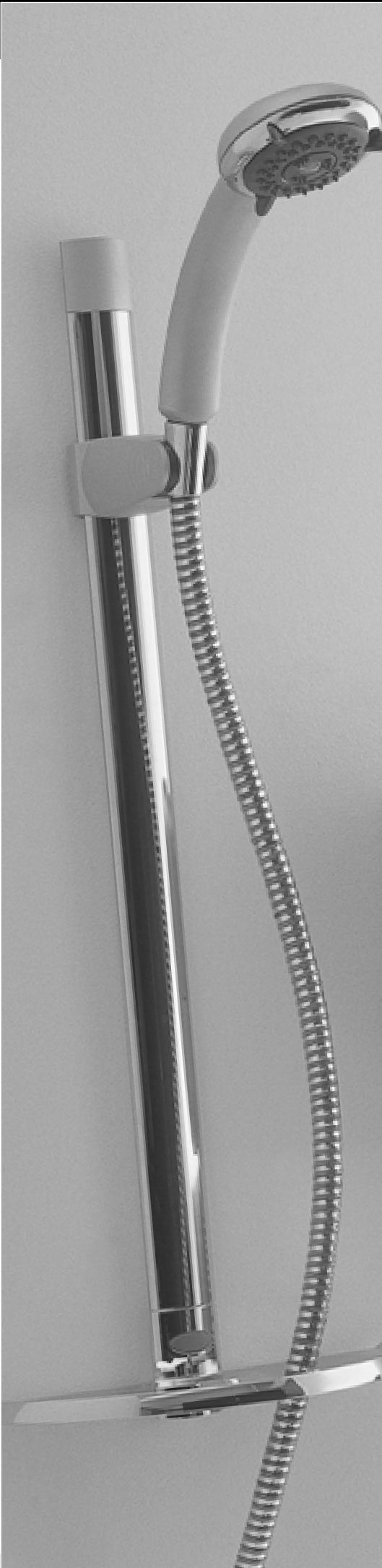

Fig 8 - Spare parts.









Guarantee

Thank you for purchasing a NewTeam product, which has been designed, manufactured and tested, in the U.K., to the highest standards.

Guarantee. 2 Years, 1 Year - Parts and Labour Second Year- Parts Only

This is provided that:

1. The guarantee registration card is completed and returned within ten days complete with a copy of proof of purchase.
2. The product is installed and operated in accordance with our instructions and has not been misused or damaged.

This in no way affects your statutory rights as a consumer.

The information on the Guarantee card helps NewTeam to process any claims and contact you about your product and its maintenance if required. The registration of your personal details is purely for Newteam use, and the other information helps us to make products for the future.

NewTeam Shower products are designed, manufactured and tested to the highest standards.

Should a complaint arise, products are guaranteed against faulty workmanship and materials for a period of 12 months from the date of purchase, when in domestic use (second year guarantee is parts only). For your guarantee to be valid, your shower pump must be installed by a competent person, in accordance with the instruction manual.

NewTeam will repair or replace (at our option), free of charge, any faulty components during the guarantee period, provided it has been maintained and operated in accordance with our instructions, and has not been misused or damaged.

Modification or repair of this product by person(s) not authorised by NewTeam will invalidate this guarantee.

This guarantee applies to products purchased within the United Kingdom or Republic of Ireland, but does not apply to products used commercially.

This guarantee does not affect your statutory rights.

Service Policy – Replacement Parts Policy

IMPORTANT:

In the event of product or component malfunction, DO NOT tamper with or remove the product from site. Telephone NewTeam Customer Service Department on 01536 264 012 and be prepared with the date of purchase, model number and a description of the complaint.

Our service staff are fully qualified to advise on correct installation procedures and will be able to diagnose whether the fault will require a replacement part or a visit from a NewTeam engineer.

If required, a service call will be booked, and either yourself or an appointed representative (who should be a person of 18 years or over) must be present during the visit.

All site visits to product within the guarantee period will be carried out free of any parts or labour charges provided the conditions of the guarantee have been adhered to. (Second year guarantee is parts only)

All site visits to product out of guarantee will be subject to charges for parts and labour which is payable by you or your appointed representative at the time of the visit. Charges will also be levied on cancelled appointments, unless advised to NewTeam at least 24 hours in advance of the agreed date and time.

We reserve the right not to undertake work where payment cannot be made to our engineer at the time of the visit.

NewTeam hold stocks of components for all their range of products and these will be maintained for the duration of their life.

Should a product be discontinued, spare parts stocks will be maintained, but in the event of a part becoming unavailable NewTeam reserve the right to supply a substitute of equal quality.

The following payment methods can be used to obtain spare parts:

By post, pre-payment of proforma invoice by cheque or postal order.

By telephone quoting credit card (Mastercard, Visa or Visa Delta) details.

REPLACEMENT PARTS:

Tel: 01536 409 222 • Fax: 01536 409 201 • E-Mail:spares@newteam.co.uk

CUSTOMER SERVICE HOTLINE:

Tel: 01536 264 012 • Fax: 01536 409 201 • E-Mail:service@newteam.co.uk

Part No. 404-0125 Issue 02/03

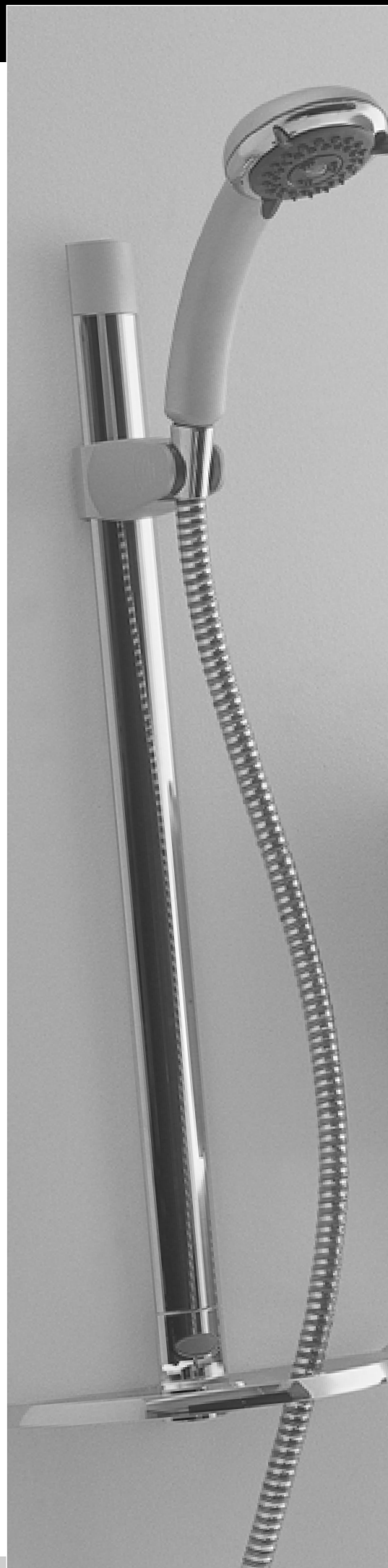



GUARANTEE CARD

Please post immediately enclosing a copy of proof of purchase

FOR NEWTEAM USE
AFFIX PRODUCT LABEL HERE
This label identifies your product and provides all the information needed

**NewTeam Power Shower
1000-XT**

Proof of purchase enclosed
YES NO

NAME: _____
ADDRESS: _____

POSTCODE: _____
DATE OF PURCHASE: _____
PRODUCT PURCHASED FROM: _____
TOWN: _____

NewTeam's philosophy is to offer outstanding products with quality and integrity, please help us by taking the time to answer the following questions. Thank you.

MARKETING INFORMATION

- 1. Please state your profession: Plumber Builder Electrician Customer
Other (please specify) _____
- 2. Please state the reason for purchasing a shower: New Build Replacement
Renovation Other (please specify) _____
- 3. If the product is a replacement shower, please state the type and make of the shower it is replacing: _____
- 4. What influenced you to purchase the 1000-XT Power Shower? Advertisement
Trade Press Recommendation from Stockist Recommendation from Installer
Other (please specify) _____
- 5. Please state your main reason for purchasing the 1000-XT Power Shower:
NewTeam Product Knowledge Product Features Product Styling Price
Other (please specify) _____

Please tick here if you do not require any further information or product updates from NewTeam

POST BACK
FOLD AND TAPE AS INSTRUCTED OVERLEAF



Please tape down

Please tape down

3rd Fold

Affix
Stamp



NewTeam Ltd.

Customer Service Dept.
Brunel Road
Earlstrees Industrial Estate
Corby
Northants
NN17 4JW

1st Fold

2nd Fold