

Glow·worm

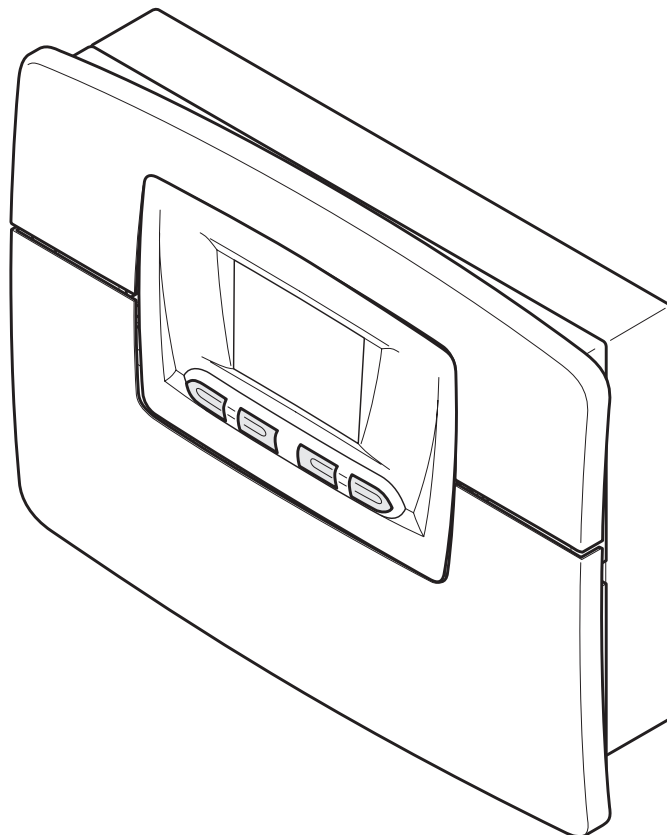
Clearly Solar

Installation and Servicing

System Wiring

including

Fluopro
Solar Control



Customer Service:

01773 596510

Technical Helpline:

01773 828300.

General and Sales enquiries:

Tel. 01773 824639

Fax: 01773 820569

To register your Glow-worm appliance call:

0800 0732142

Benchmark places responsibilities on both manufacturers and installers. The purpose is to ensure that customers are provided with the correct equipment for their needs, that it is installed, commissioned and serviced in accordance with the manufacturer's instructions by competent persons and that it meets the requirements of the appropriate Building Regulations. The Benchmark Checklist can be used to demonstrate compliance with Building Regulations and should be provided to the customer for future reference.

Installers are required to carry out installation, commissioning and servicing work in accordance with the Benchmark Code of Practice which is available from the Heating and Hotwater Industry Council who manage and promote the Scheme. Visit www.centralheating.co.uk for more information.



These instructions consist of, Installation, Commissioning, Service and Fault Finding. The instructions are an integral part of the appliance and must be handed to the user on completion of the installation.

CONTENTS	DESCRIPTION	SECTION	PAGE
GENERAL INFORMATION	Regulations		4
	Electrical Supply		4
	Testing and Certification		4
	CE Mark		4
	Safety Instructions		4
	Intended Use		5
	Documents		5
	Servicing		5
	Cleaning		5
	Recycling		5
INSTALLATION	Specification	1	5
	Functions	2	6
	Installation	3	7
	Electrical Installation	4	9
	Commissioning	5	19
MAINTENANCE	Service / Diagnostics	6	24
	Sensor Characteristics	7	26
	Control - Fault Finding	8	27

WARNINGS

SAFETY

The fluropro must be installed by a competent person, who is responsible for adhering to the existing standards and regulations.

ALTERATIONS

Under no circumstances should you ever attempt to make alterations to these components or any other part of the system

SEALED COMPONENTS

Under no circumstances must the user interfere with or adjust sealed parts.

IMPORTANT

Danger of death by electric shock! All live parts of the system may be installed, serviced and repaired only by a qualified servicing company!

Risk of overvoltage! Earth the solar circuit as potential equalisation and protection against overvoltage! Attach earthing pipe clips to the solar circuit pipes and connect the clips to a potential rail with a 16mm² copper cable.

Regulations

When installing and commissioning the system, the current version of regulations below shall be observed.

The electrical installation must be installed by a **competent person** and in accordance with the relevant standards

Electrical Supply

The product MUST be earthed.

All system components shall be of an approved type and all wiring to current I.E.E. wiring regulations.

External wiring must be correctly earthed, polarised and in accordance with the relevant standards.

In GB, this is BS 7671.

In IE, this is the current edition of ETCI rules.

The product MUST be connected to a permanent 230V ac, 50Hz supply.

Connection of the whole electrical system of the product, including any heating controls, to the electrical supply MUST be through one common isolator and must be fused 3 Amp maximum.

Isolation should be by a double pole switched fused spur box, with a minimum gap of 3mm for both poles. The fused spur box should be readily accessible and preferably adjacent to the product. It should be identified as to its use.

Alternatively connection can be made through an unswitched shuttered socket and 3A fused 3-pin plug both to the current issue of BS 1363, provided they are not used in a room containing a bath or shower.

Wiring to the product must be PVC 85°C insulated cable, not less than 0.75mm² (24/0.20mm).

Testing and Certification

This product is tested and certificated for safety and performance. It is, therefore, important that no alteration is made to the product, without permission, in writing, by Glow-worm.

Any alteration not approved by Glow-worm, could invalidate the certification, warranty and may also infringe the current issue of the statutory requirements.

CE Mark

The CE mark on the Fluropro solar control indicates that it complies with the basic requirements of the applicable directives as stated on the data badge.

“Benchmark scheme”

Glow-worm support the Benchmark initiative. It is very important that the service record is completed by the installation engineer and handed over to the user.

Safety Instructions

The entire solar system must always be installed and operated in accordance with recognised technical standards.

IMPORTANT: Danger of death by electric shock! All live parts of the system may be installed, serviced and repaired only by a qualified servicing company!

IMPORTANT: Risk of overvoltage! Earth the solar circuit as potential equalisation and protection against overvoltage! Attach earthing pipe clips to the solar circuit pipes and connect the clips to a potential rail with a 16mm² copper cable.

General Information

Intended use

The Fluropro solar control is a temperature differential controller for solar DHW provision with a cylinder reheat programmer for a supplementary boiler.

The control is suitable for controlling solar systems with a collector array and a storage cylinder.

The Fluropro solar control can be used for controlling a second collector array

If a second collector array is connected, an additional collector sensor (available as an accessory) must be installed. It is possible to determine the solar gain by using an additional gain sensor (supplied with Glow-worm Clearly Solar sets).

The Fluropro solar control is a state-of-the-art control which has been constructed in accordance with recognised safety regulations. Nevertheless, improper use can cause serious or fatal injury to the user or others, and the appliance or other property can be damaged.

The manufacturer or supplier is not liable for any damage resulting from improper use.

The control is not suitable for outdoor use and must be installed in a dry room.

Documents

Please retain these instructions as well as any documents enclosed, for future reference.

We accept no liability in case of damage due to the non-compliance of these instructions.

Servicing

To obtain service, please call your installer or Glow-worm's own service organisation using the telephone number on the inside front cover of this booklet.

Cleaning

You can clean the housing of the Fluropro solar control with a damp cloth and a little soap.

NOTE: Do not use scouring or cleaning agents which could damage the display.

Recycling

The Fluropro solar control comprises many recyclable parts. The packaging and control shall not be disposed of with domestic waste but according to the current regulations.

1 Specification

FLUROPRO SPECIFICATION	
Height	200mm
Width	275mm
Depth	55mm
Operating voltage	230/50V AC/Hz
Power consumption	10W max.
Contact load of output relays (max.)	2A
Maximum total current	4A
Shortest switching interval	10 mins
Power reserve	30 mins
Maximum ambient temperature	50°C
Sensor operating voltage	5V
Sensor wires	0.75mm ² min
230V mains cable	1.5mm ² min.
Electrical Protection	IP 20

14276

2 Functions

2.1 Solar gain

The Fluropro solar control works on the principal of differential temperature control. The control always switches on the collector pump when the difference in temperature (collector temperature - cylinder temperature) is greater than the programmed activation difference.

The controller switches off the collector pump when the difference in temperature (collector temperature - cylinder temperature) is less than the programmed deactivation difference.

The installation engineer activates and configures the solar gain function within the Fluropro installer menu.

The solar gain is determined from:

- The difference of temperature between the collector flow and return.
- The flow rate setting of the flow rate adjuster.
- The operating time of the collector pump.

During installation the engineer sets the actual flow rate and enters the setting into the solar control. The solar gain is calculated and displayed by the solar control. The total gain can be called up and reset in the installer menu.

2.2 Solar gain modulation

The rate of solar gain can be modulated to ensure the solar heat at the bottom of the cylinder has sufficient time to dissipate to the top of the cylinder. This maintains demand for solar energy and prevents excessive on and off periods that are inefficient.

The modulation is achieved by means of more frequent on and off operations of the solar pump during solar demand. The pump is switched on and off and the rate depends upon the difference between the collector temperature and lower cylinder sensor. When the activation difference is reached, the function is started (if activated) with an activation duration of 50 % - i.e., the pump is switched on for 30 seconds and then switched off for 30 seconds. If the difference in temperature increases, the activation duration is prolonged (e.g., 45 sec. on, 15 sec. off). When the difference in temperature decreases, the activation duration is reduced (e.g., 20 sec. on, 40 sec. off). The period length is always a minute.

2.3 Cylinder reheat

The cylinder reheat function allows the cylinder to heat up to the required temperature during a set time window, even if the solar gain is insufficient. In this case the water can be reheated using an external boiler or the immersion heater. You can set up times for reheating the solar cylinder, refer to Settings section in Instructions for Use.

2.4 Reheat delay

To prevent unnecessary cylinder reheating by a boiler or an immersion heater, the Fluropro solar control includes a reheat delay function. This function delays the cylinder reheat by up to 30 mins if solar gain is available.

If the solar pump is off and the desired cylinder temperature is not reached after the delay period, the cylinder will be reheated using an external boiler or the immersion heater.

The reheat delay function is activated by an engineer within the Fluropro installer menu.

2.5 Legionella protection

The Legionella protection function is designed to kill germs in the cylinder and pipes.

When the function is activated, the cylinder, the hot water pipes, and the circulation pump (if installed), are brought to a temperature of 70°C on the programmed day(s) and at the programmed time

In doing so, the cylinder temperature is raised to 70°C and the corresponding circulation pump is switched on (if installed).

First, an attempt will be made using solar gain alone to reach the target temperature over a 90 min. period. If this is not successful, the Legionella protection is carried out using an external boiler or an immersion heater, whichever has been set up for this thermal protection. The Legionella protection function will stop once a temperature of at least 70°C has been maintained for a period of 30 minutes.

The installation engineer activates the Legionella protection function within the Fluropro installer menu and specifies whether the thermal disinfection should take place at 3:30 p.m. or at 4:00 a.m., i.e. offset gain versus cheaper electricity.

2.6 Anti-seize protection for pumps

If no pumping has occurred for 23 hours, all installed pumps are switched on for approx. 3 seconds to prevent pumps from seizing.

2.7 Secondary recirculation

The Fluropro solar control includes a programmer channel for a DHW secondary return. A secondary return should not be used with Glow-worm twin coil unvented solar cylinders.

2.8 Calendar

The controller is equipped with a calendar so that it can automatically adjust the clock by 1hr between GMT and BST. To activate, simply enter the current date within the Fluropro installer menu

NOTE: In the event of a power failure, the controller only has a power reserve of 30 minutes. After 30 minutes, the internal clock stops and the calendar will not automatically resume function once power has been restored. In this case the time and date will need to be reset.

3 Installation

3.1 Contents of sets

Using Table 1, verify the contents of the Fluropro solar control set.

Item	Quantity	Components
1	1	Fluropro
2	1	Collector sensor
3	2	Cylinder sensor

Table 1

The gain sensor is a separate item and is also supplied as part of the Glow-worm Clearly Sets.

3.2 Installing cylinder sensors

The cylinder sensors are designed so that they can be used as immersion sensors or surface sensors. Install the two sensors in the solar cylinder, see diagram 3.1, and connect to the wiring as shown in wiring diagram. When used as a surface sensor, the sensor is secured to the flow pipe or the return pipe as appropriate using the supplied tension band, see diagram 3.2. In order to guarantee good heat transfer, the sensor is flat on one side. We also recommend that the pipe with the sensor is insulated, in order to enable the best possible measuring of temperature. Refer to cylinder instructions for the location of sensors and specific fitting instructions.

3.3 Accessories

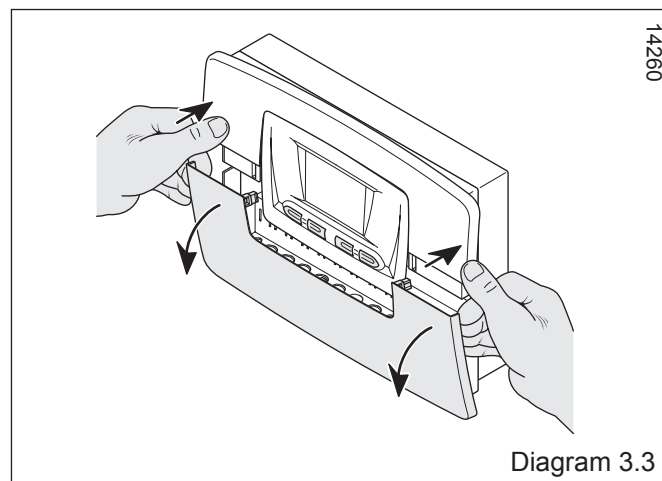
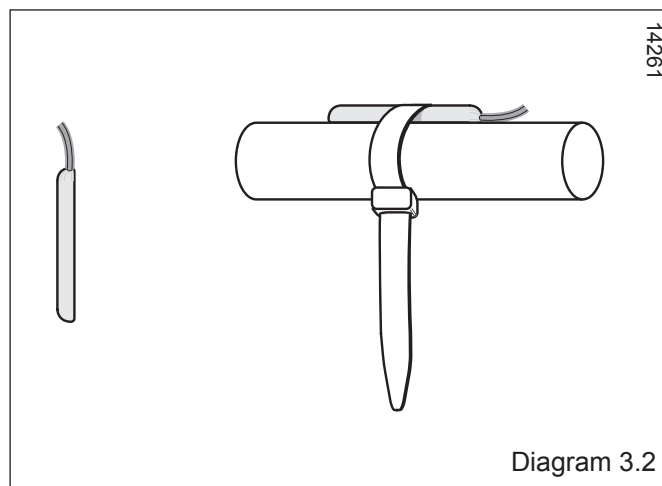
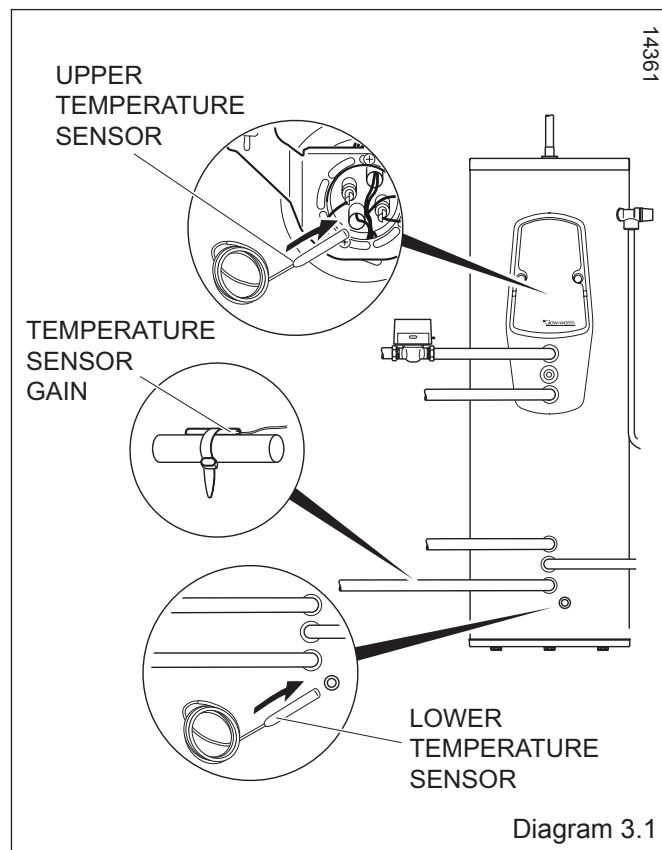
If a second collector array is connected, it is necessary to install a second collector sensor from the Glow-worm accessory range.

3.4 Installing the Fluropro housing

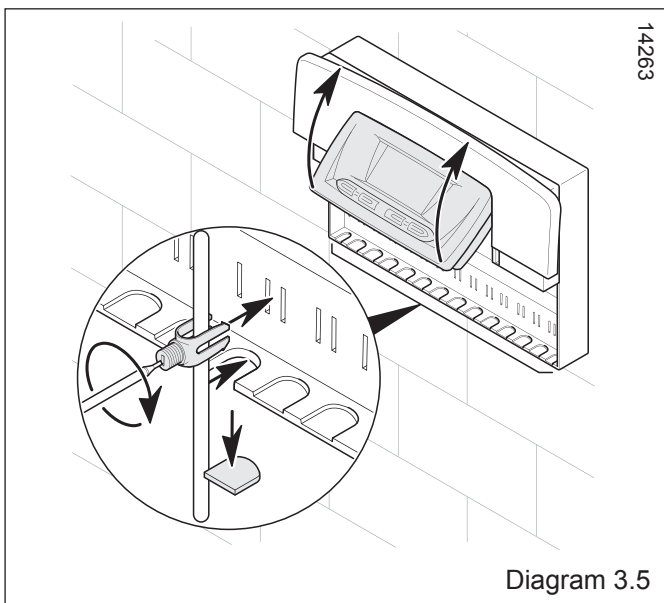
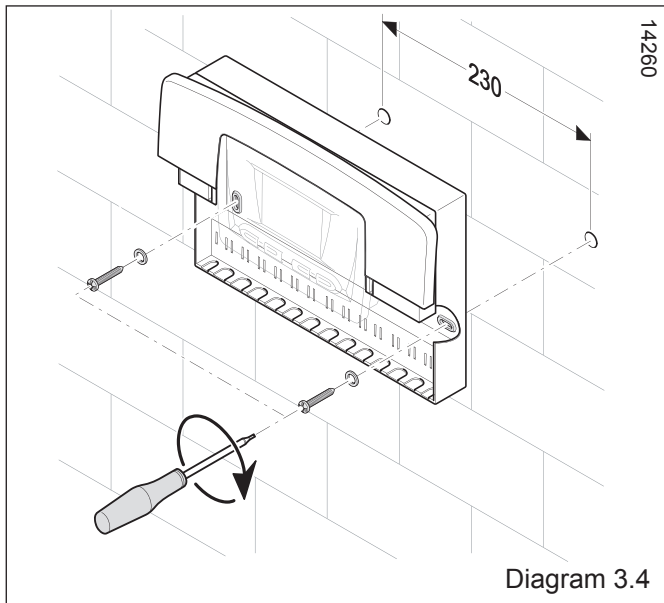
The Fluropro solar control is designed to be mounted on a wall. The wiring terminals within this control includes the connectors. These connectors must be used for all wiring to this control.

The cover consists of two parts, which can be removed separately:

- As shown in diagram 3.3, pull the lower front cover off of the controller housing.
- Mark the position of both holes and drill, see diagram 3.4.
- Select wall plugs to suit, and screw the controller housing on tightly.



3 Installation



- Lift up the control panel, see diagram 3.5.
- Wire the controller according to the selected hydraulic plan (see Section 4 Electrical installation).
- Secure all cables with the accompanying cable clamps.
- Push the control panel back into place.
- Re-attach the lower front cover.

4 Electrical Installation

Electrical Supply

The product **MUST** be earthed.

All system components shall be of an approved type and all wiring to current I.E.E. wiring regulations.

External wiring must be correctly earthed, polarised and in accordance with the relevant standards.

In GB, this is BS 7671.

In IE, this is the current edition of ETCI rules.

The product **MUST** be connected to a permanent 230V ac, 50Hz supply.

Connection of the whole electrical system of the product, including any heating controls, to the electrical supply **MUST** be through one common isolator and must be fused 3 Amp maximum.

Isolation should be by a double pole switched fused spur box, with a minimum gap of 3mm for both poles. The fused spur box should be readily accessible and preferably adjacent to the product. It should be identified as to its use.

Alternatively connection can be made through an unswitched shuttered socket and 3A fused 3-pin plug both to the current issue of BS 1363, provided they are not used in a room containing a bath or shower.

Wiring to the product must be PVC 85°C insulated cable, not less than 0.75mm² (24/0.20mm).

IMPORTANT: Risk of fatal electric shock from touching live connections.

Before working on the system wiring, including the Fluropro, isolate the power supply.

The circuit board can be damaged if short circuited through the connection leads. For safety purposes, a max. of 30 mm of insulation may be removed from the ends of 230 V leads which will be connected to Fluropro wiring connectors. If more insulation is removed, there is a risk of short circuiting the circuit board.

When exchanging the solar controller in an existing system, sensor-curve characteristics should be taken into consideration and the sensors should be replaced if necessary!

The immersion heater must be installed with an additional relay or contactor with a circuit-breaking capacity of at least 16 A. Never operate an immersion heater in connection with the Fluropro without an additional external relay or contactor.

4 Electrical Installation

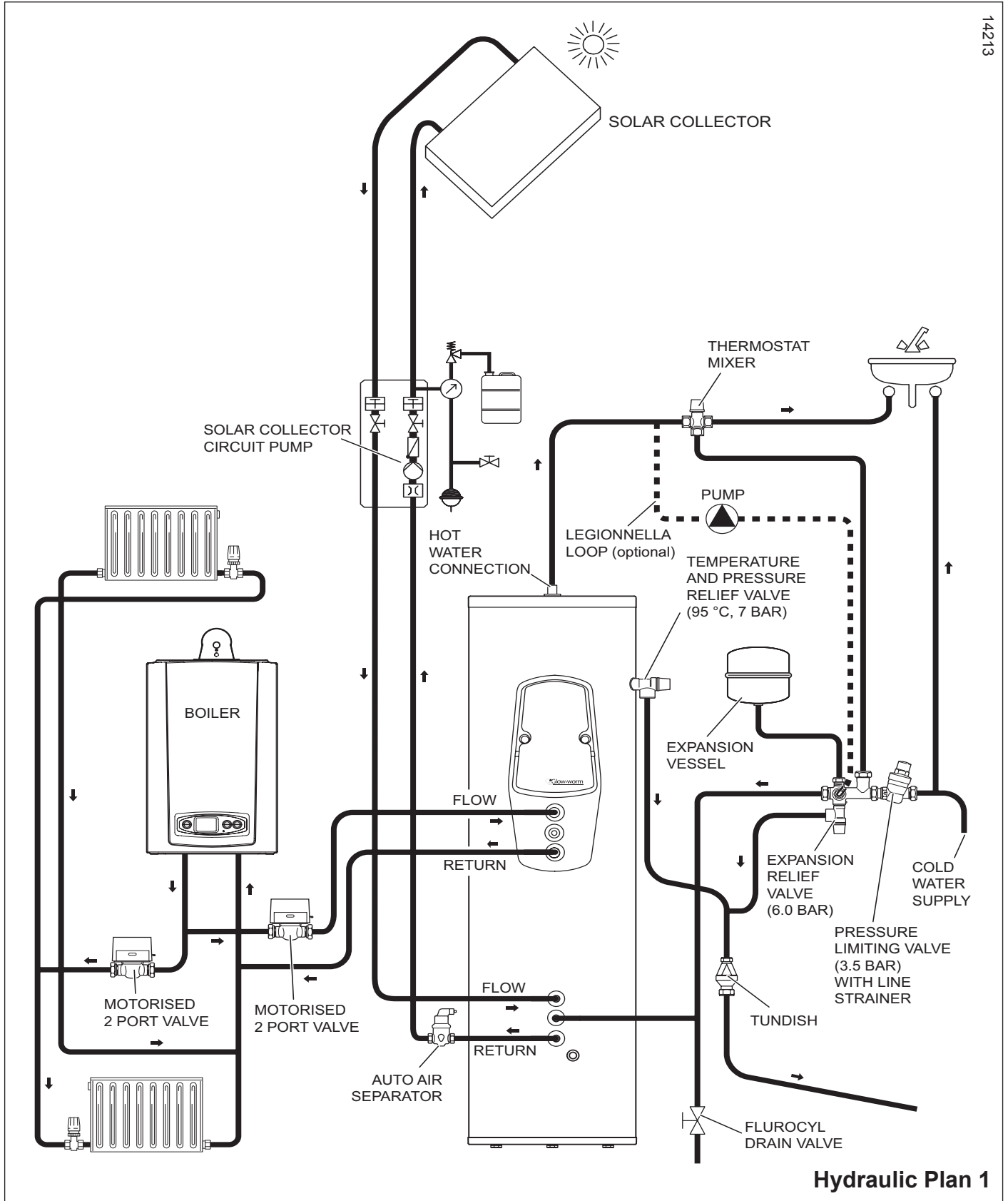
4.1 Hydraulic plan

IMPORTANT: Reference cylinder instructions for wiring to cylinder thermostats and thermal cut-outs.

(**NOTE:** The Glow-worm Flurocyl cylinder is fitted with a solar thermal cut-out - other manufacturers cylinders may not be fitted with this device).

IMPORTANT: To simplify the system wiring, two hydraulic plans are stored in the Fluropro solar control.

Hydraulic Plan 1 includes one collector array and **Hydraulic Plan 2** includes two collector arrays, (separate circuits and pump stations). The relevant plan must be selected within the Fluropro installer menu.

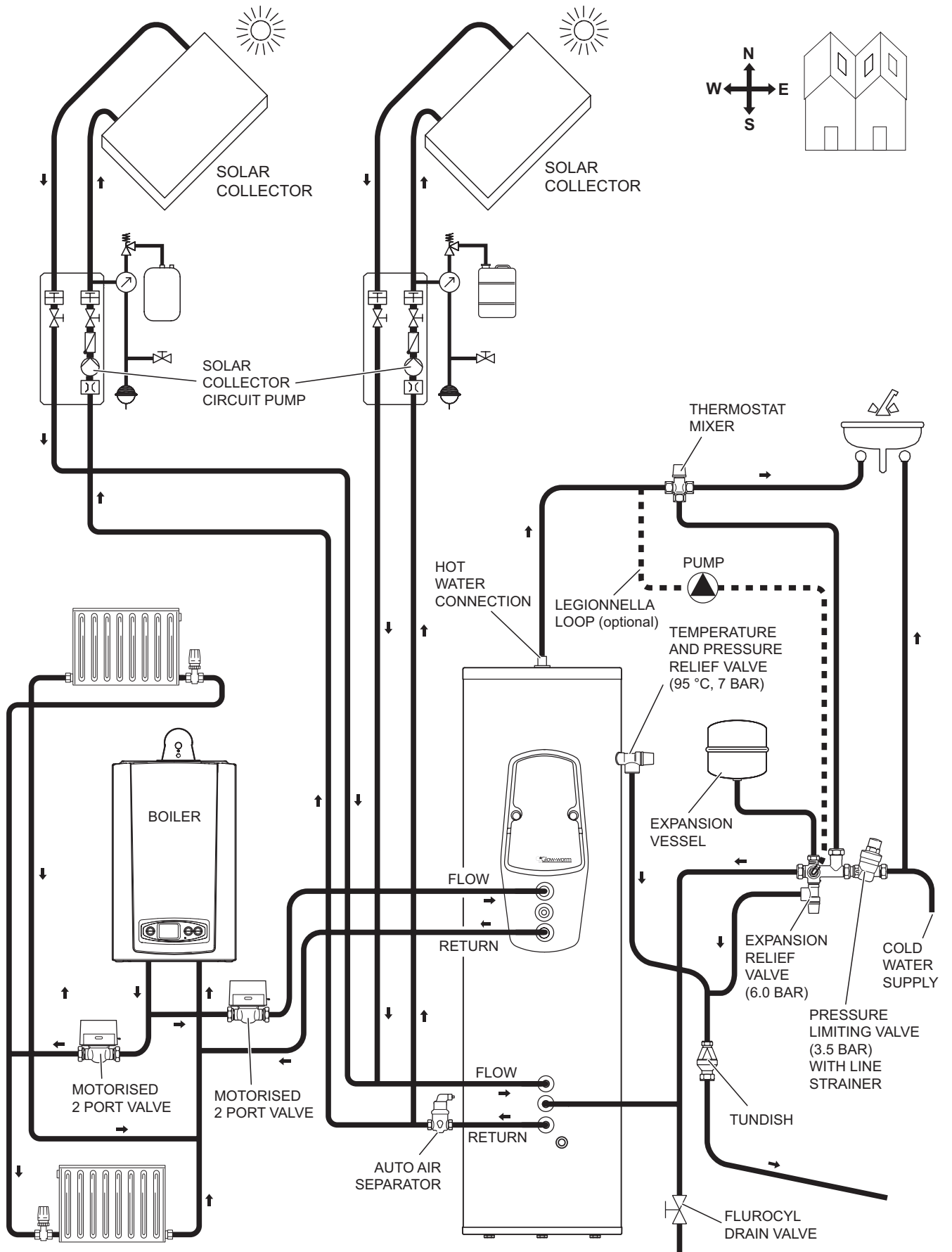


14213

4 Electrical Installation

14212

Collector arrays setup for East / West orientation



Hydraulic Plan 2

4 Electrical Installation

Boiler	Wiring	Solar Circuit Control	DHW programming	CH programming	Diagram
Flexicom hx / sx, Ultracom hxi / sxi, old hxi / sxi 3rd party ov / sys	11 way terminal block	Fluropro	Fluropro	3rd party programmer	4.1
			3rd party programmer	3rd party programmer	4.2
Ultracom hxi / sxi with options board	11 way terminal block	Fluropro	Internal programmer	Internal programmer	4.3
			Fluropro	Internal programmer	4.4
				Climapro or Climapro RF	4.5
Installer interface options for Glow-worm boilers					4.6

4 Electrical Installation

14793

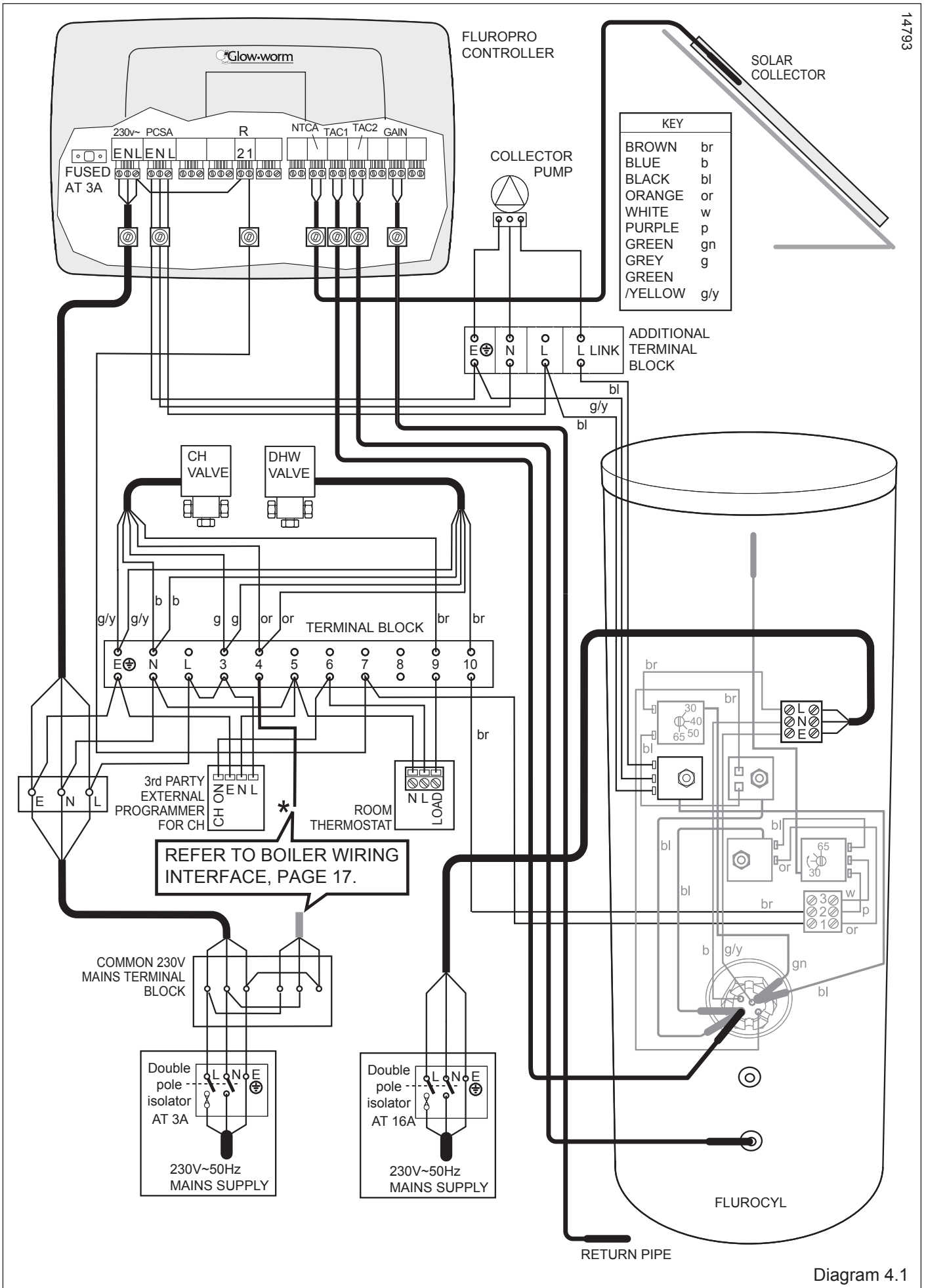


Diagram 4.1

4 Electrical Installation

14794

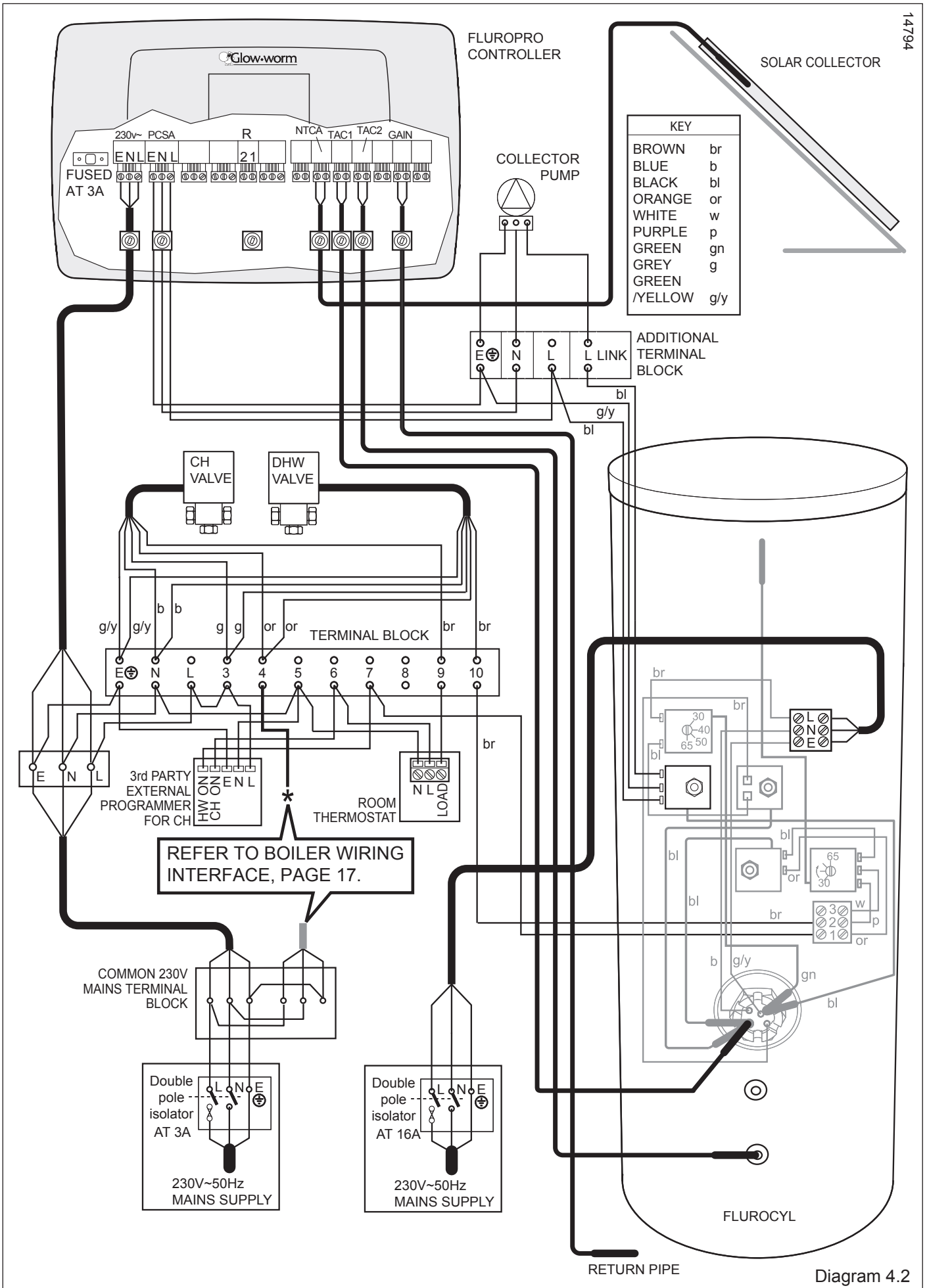


Diagram 4.2

4 Electrical Installation

14795

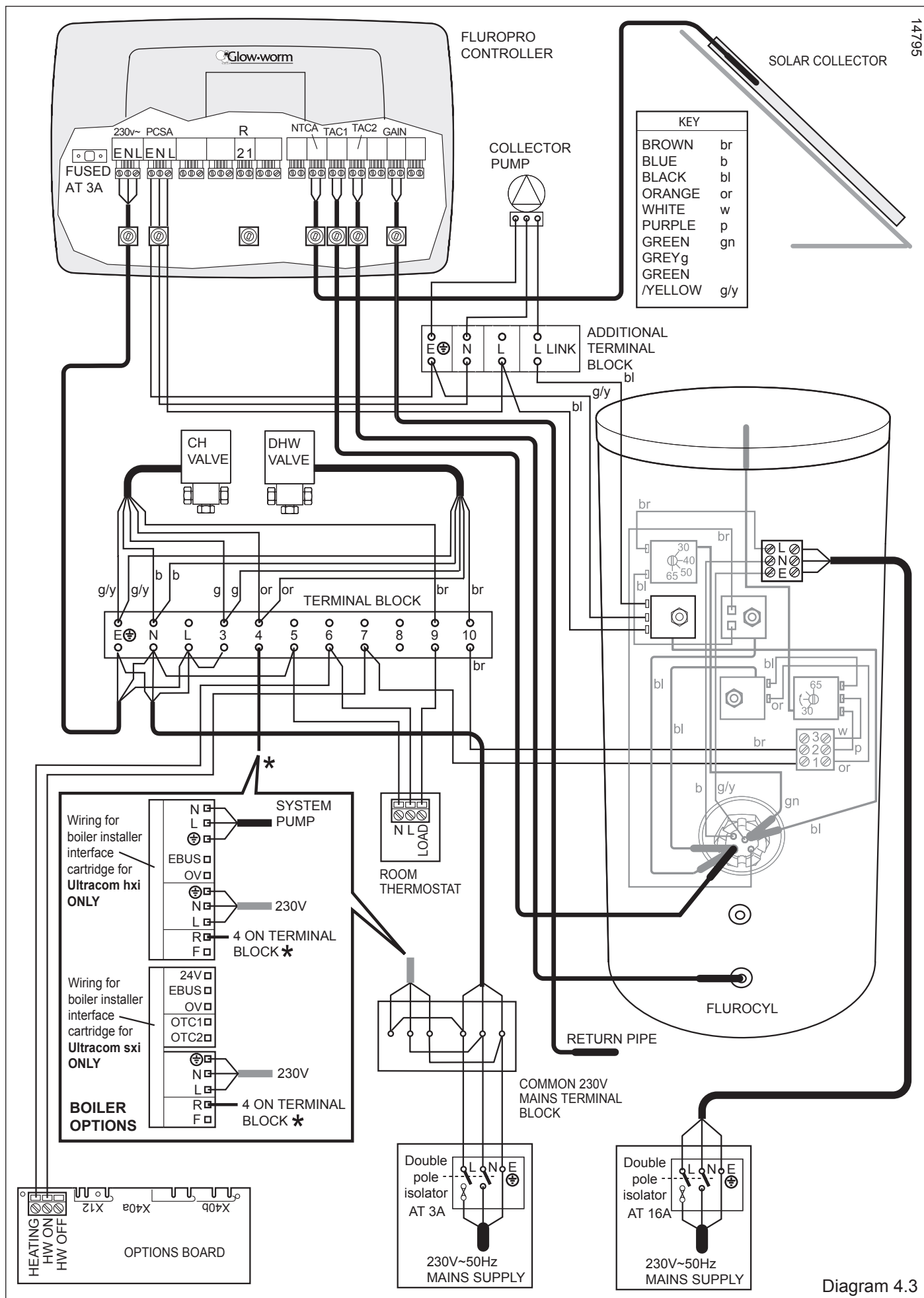


Diagram 4.3

4 Electrical Installation

14796

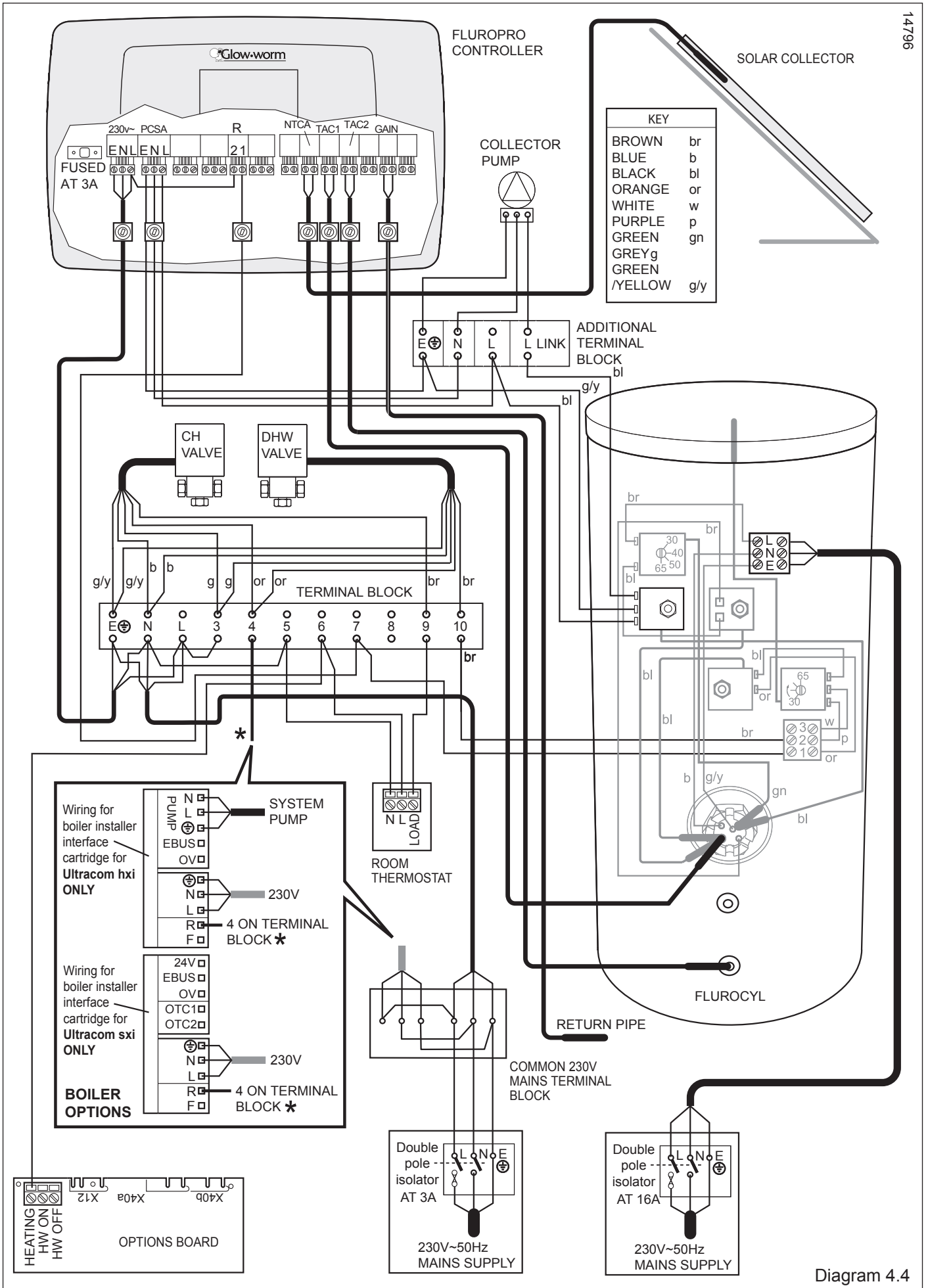


Diagram 4.4

4 Electrical Installation

14797

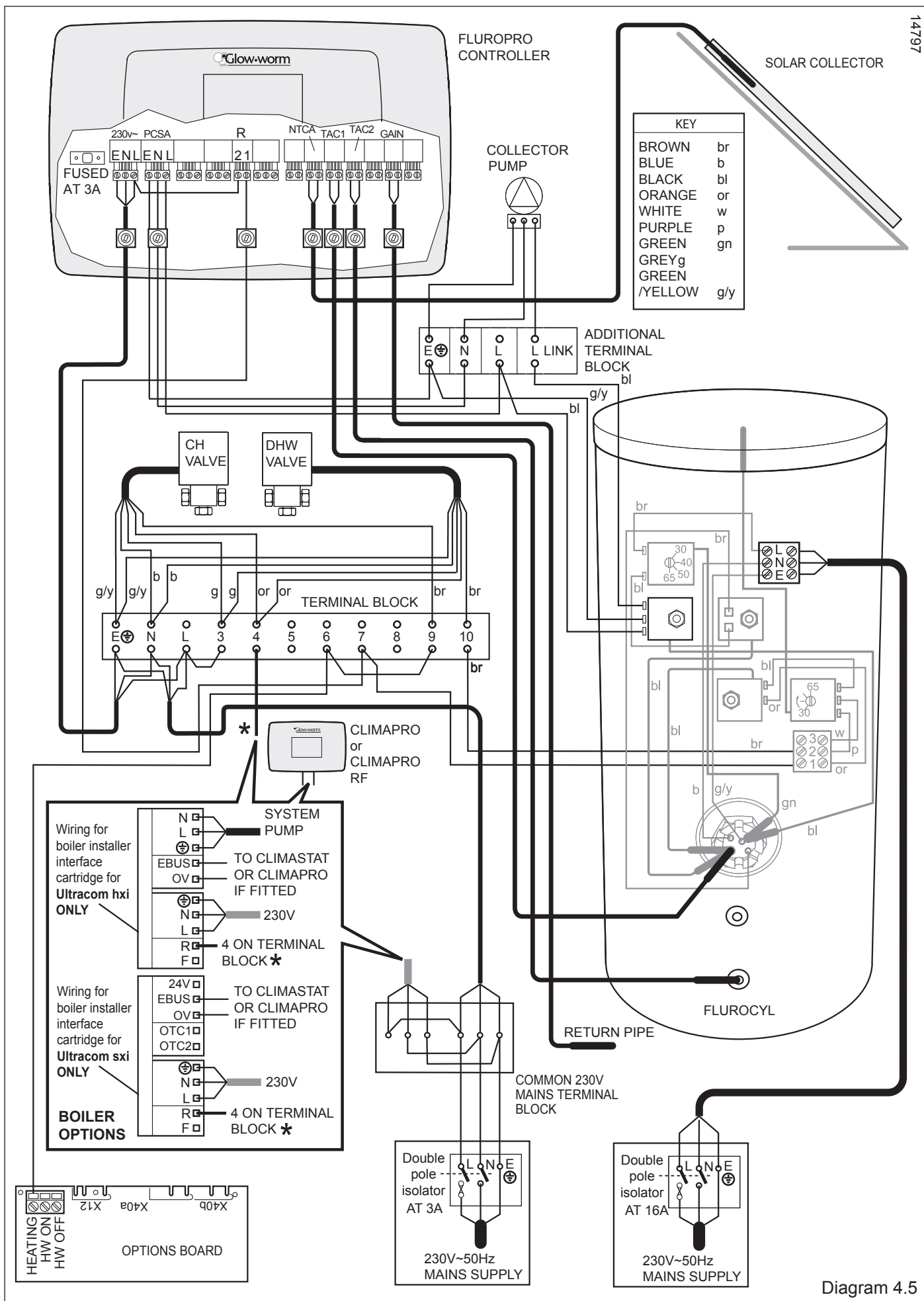


Diagram 4.5

4 Electrical Installation

14839

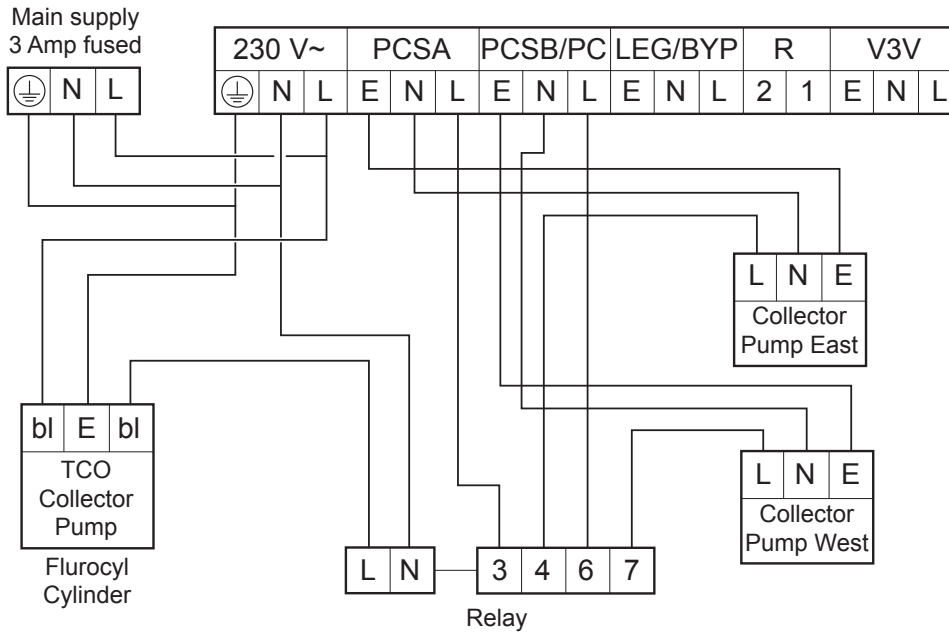


Diagram 4.6

4.2 Additional wiring for East/West installations.

To maintain compliance with G3 regulations when using an East/West arrangement with independant pump station control, it is necessary to install an additional external relay. (Drayton RBI shown, see diagram 4.6, but any suitable double pole relay or 2 separate relays could be used).

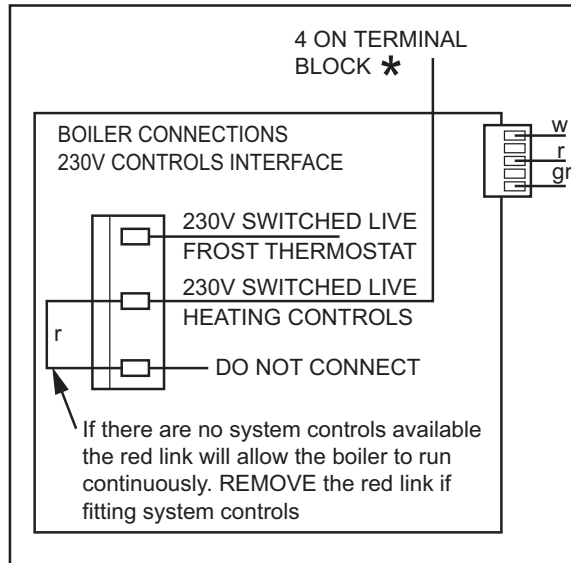
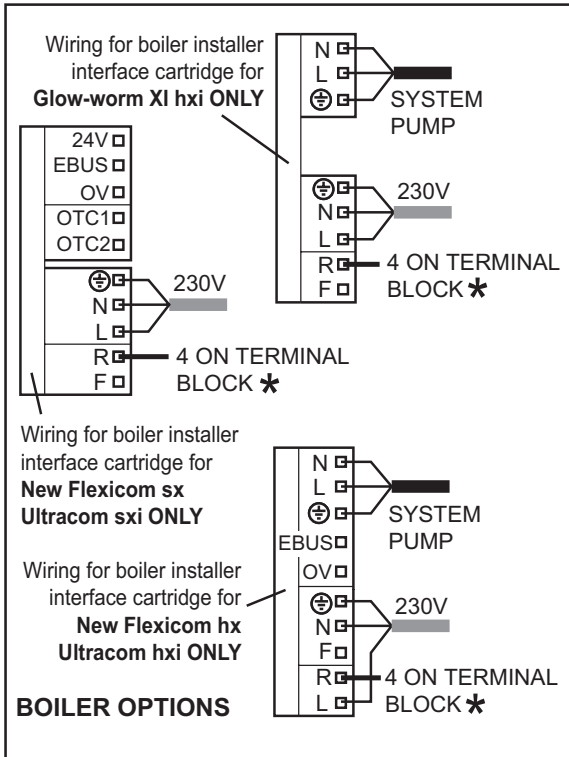
4.3 Using Third party heating appliances in conjunction with the Glow-worm solar system solution.

It is possible to use a non Glow-worm boiler with the Glow-worm solar system solution which is controlled by the Fluropro.

In order to achieve this, consult your boiler installation manual to determine the switched live connection to the boiler. The switched live input is the 230v input voltage to the boiler which makes a heating demand.

The heating demand to your non Glow-worm boiler will be provided from the Fluropro or a third party programmer at terminal 4 of the wiring centre.

14277



INSTALLER INTERFACE OPTIONS FOR GLOW-WORM BOILERS

Diagram 4.7

5 Commissioning

14722

User Control Panel

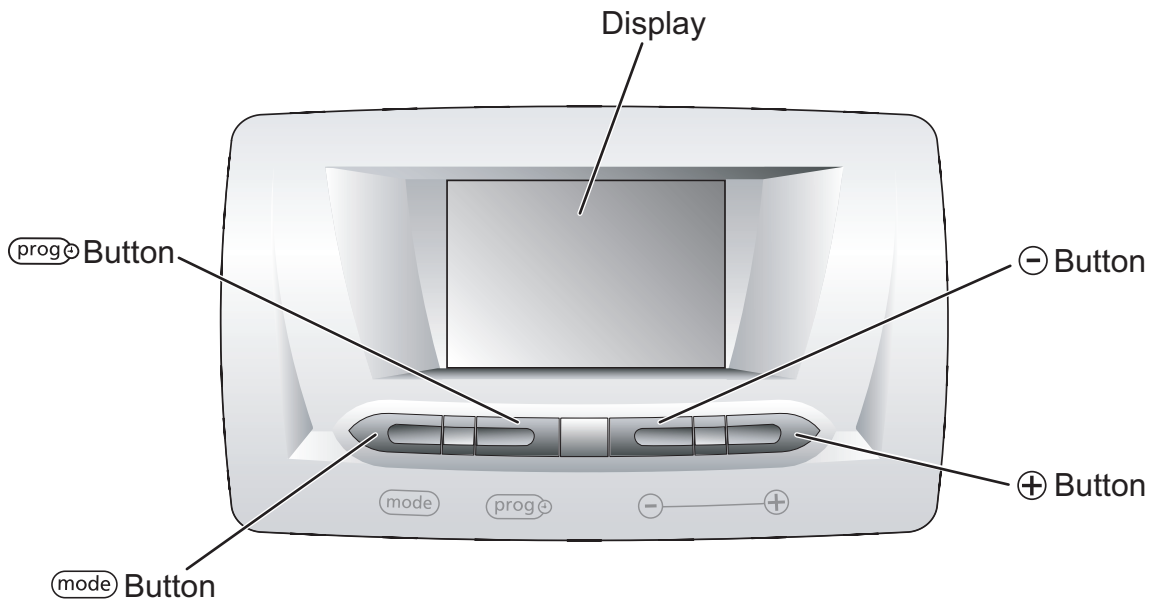
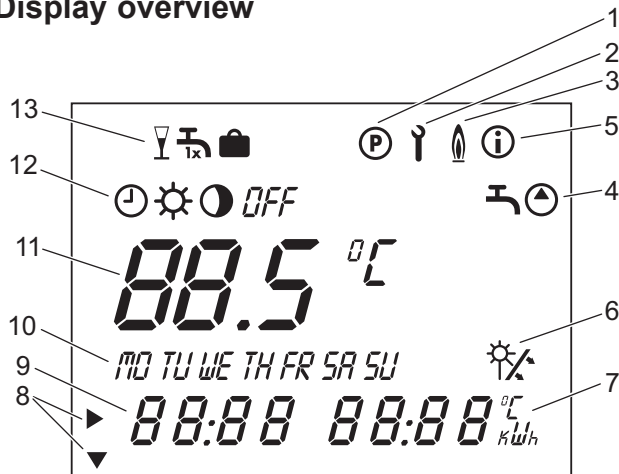


Diagram 5.1

Display overview



Key

- 1 Programming menu
- 2 Service/diagnostic menu
- 3 Cylinder reheat
- 4 Not used
- 5 Info menu
- 6 Solar gain (blinks if solar gain is available)
- 7 Units
- 8 Cursor
- 9 Multifunction display
- 10 Days of the week
- 11 Target/actual value
- 12 Operating modes
- 13 Special functions

Display symbols

Timer programs:

- Cylinder reheat
- Not used

Operating modes:

- Cylinder reheat function in timed mode
- Cylinder reheat function in constant mode
- No cylinder reheat

- OFF* Solar pump(s) not activated
- OFF* No cylinder reheat

Special functions:

- Party
- Advanced cylinder reheat
- Holiday function

Diagram 5.2

5 Commissioning

Installer menu

Access the installer menu by pressing the **(mode)** button for 3 seconds.

Press the **(mode)** button for 3 seconds again to return to the operating menu.

These parameters should only be adjusted by the installation engineer.

5.1 Setting the system parameters

Certain system parameters have to be set in order to optimise the system for the respective conditions. These parameters are all together in the installer menu and should only be set by the installation engineer.

Access the installer menu.

IMPORTANT:

- The hydraulic plan, flow rate and current date must be entered.
 - It is also recommended that the solar gain modulation and cylinder reheat delay are activated.
 - Ask the householder how long they normally program the DHW to be on for before they actually require it. If one hour or more, activate the cylinder reheat delay.
 - It may not be necessary to change any other settings from the factory defaults
- Exit the installer menu.

The following table gives an overview of all system parameters and their factory settings and range.

Display	Press + or - to adjust Press PROG to accept	Setting range	Factory setting
	Changing the hydraulic plan 1. 1 collector array. 2. 2 collector arrays (East/West system). 3. Not used.	1, 2, 3	1
	Setting the flow rate When setting the the required flow rate, please observe the measurement units, required for display of Solar gain.	0 – 165 litres/min	0
	Resetting the solar gain. The solar gain is reset to 0 by turning the dial to 1.	-	-
	Resetting the operating hours. The operating hours are reset to 0 by turning the dial to 1.	-	-
	Setting the max. temperature for cylinder 1	20 to 90 °C	75 °C
	Setting the activation difference for cylinder 1. (The activation difference should always be 2 K greater than the deactivation difference)	2 – 15 K	7 K
	Setting the deactivation difference for cylinder 1. (The deactivation difference should always be 2 K less than the activation difference)	1 – 10 K	3 K

5 Commissioning

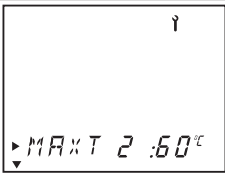
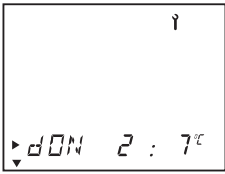
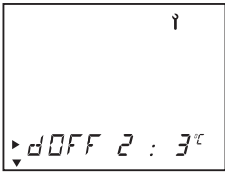
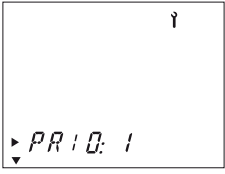

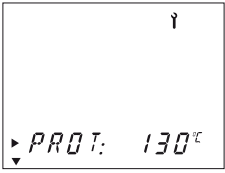



Display	Turn the dial to adjust	Setting range	Factory setting
	Not used.	20 - 90 °C	60 °C
	Not used.	5 - 12 K	7 K
	Not used.	1 - 10 K	3 K
	PRIO Cylinder with highest priority	1, 2	1
	AGEL: Frost protection function	-5°C - 10°C; OFF	OFF
	PROT Solar circuit safeguard	OFF, 110°C - 150°C	130°C
	CST: Collector type 1 = Flat collector 2 = Tubular collector	1, 2	1
	LEG Anti-Legionella function	OFF, 1, 2, 3, 4, 5, 6, 7, 1-7	OFF
	LEGT: Start time for the anti-Legionella function	00:00 - 23:50	04:00

Table 1 System parameters (continued)

5 Commissioning

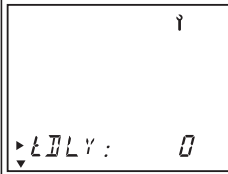
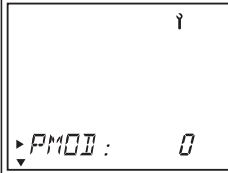
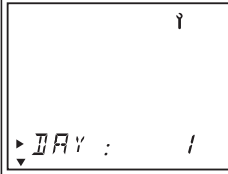
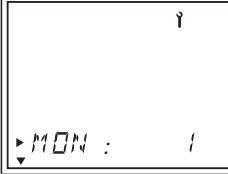

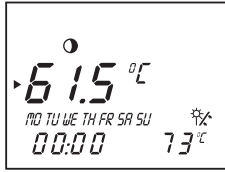
Display	Turn the dial to adjust	Setting range	Factory setting
	Cylinder reheat delay function	0=deactivated; 1=activated	0
	Solar gain modulation function	0=off; 1=on	0
	Setting the current day	1 - 31	0
	Setting the current month	1 - 12	0
	Setting the current year	2000 - 2159	2000

Table 1 System parameters (continued)

5 Commissioning

Adjust the solar water heating target temperature setting



Important: Set the solar water heating target temperature to the maximum adjustment

Press and hold the \oplus button to increase the solar water heating target temperature, or press and hold the \ominus button to decrease the solar water heating target temperature. Once \oplus or \ominus is pressed a cursor appears beside the current target temperature. The temperature begins to flash as it is being adjusted. Once the desired target temperature is selected wait 5 seconds. The display returns to running screen.

5.2 Resetting parameters to default

You can reset the system parameters and the timer programs to the default settings by pressing the **(mode)** button for ten seconds. Then the display flashes twice and all of the parameters are reset to the factory defaults.

5.3 Benchmark

GB: It is a requirement that the “Benchmark” Installation, Commissioning and Service Record is completed and left with the user.

IE: it is necessary to complete a “Declaration of Conformity” to indicate compliance to I.S.813. An example of this is given in the current edition of I.S.813.

5.4 Hand over to the householder

- Hand over all manuals to the householder.
- Advise the householder to keep the manuals near to the system.
- Draw special attention to the safety instructions which the householder must follow.
- Review the user instructions with the householder and answer any questions.
- Show the householder how to operate the solar control, CH control and any separate DHW control.
- Inform the householder that the cylinder temperature is factory set at 65°C and that the DHW temperature can be adjusted using the TMV by the installer.
- Inform the householder that the immersion heater is intended as a standby device and should not be used simultaneously with the boiler to heat the cylinder.
- Inform the householder that they are not permitted to change the settings made on the solar system.
- Inform the householder that to ensure the continued efficient and safe operation of the solar system it is recommended that it is checked and serviced at regular intervals. The frequency of servicing will depend upon the installation conditions and usage, but in general, once a year should be enough.
- Inform the householder that the boiler and solar cylinder should be serviced by a qualified engineer annually.

Leave these instructions and the “Benchmark” Installation, Commissioning and Service record document with the user.

6 Service / Diagnostics

6 Service menu

Access the service menu by simultaneously pressing the **(mode)** button and **(↺)** button for approx. 3 seconds. All relays and sensors can be controlled and checked in this menu (refer to the system wiring manual included with Fluropro).

The display returns to the main operating menu if you press the **(mode)** button and **(↺)** button for 3 seconds. The relays and sensors should be checked only by the installation and service engineer.

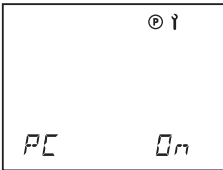
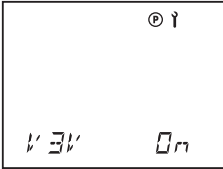
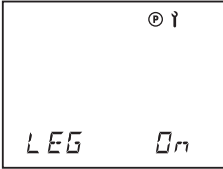
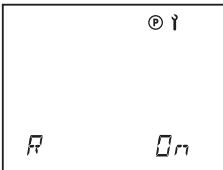
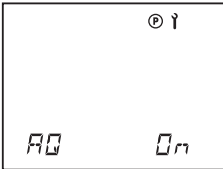
Display	Relay check/sensor values	Test procedure
 <p>PCSA On</p>	Collector pump test (array 1)	Collector pump 1 on, all other actuators off
 <p>PC On</p>	Collector pump test (array 2 if applicable)	Collector pump 2 on, all other actuators off
 <p>V3V On</p>	Switching valve test	Switching valve on, all other actuators off
 <p>LEG On</p>	Legionella protection pump test	Legionella protection pump on, all other actuators off
 <p>R On</p>	Cylinder reheat 230V demand test	Cylinder reheat 230V demand on, all other actuators off
 <p>RD On</p>	Cylinder reheat demand - volt free contacts test	Cylinder demand - volt free contacts - closed circuit, all other actuators off
 <p>TAC1 24°C</p>	Upper cylinder sensor value	

Table 1 Actuators and sensors

6 Service / Diagnostics

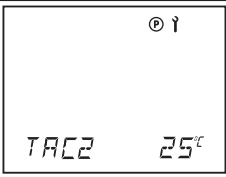

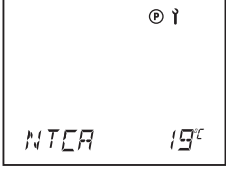

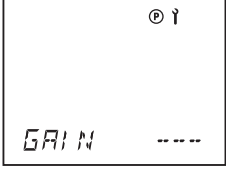
Display	Relay check/sensor values	Test procedure
	Low cylinder sensor value	
	Not used	
	Collector sensor value (array 1)	
	Collector sensor value (array 2 if applicable)	
	Gain sensor value	

Table 1 Actuators and sensors (continued)

You can check the visual display by pressing  again.

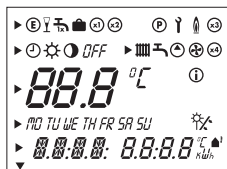


Diagram 6.1 Check visual display

With another press, the current version of the controller's software is displayed.

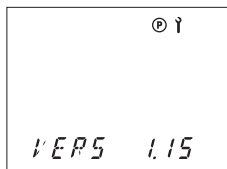




Diagram 6.2 Controller software version

You can exit the service/diagnostic level by pressing the  and  buttons simultaneously.

Emergency mode

When the Fluropro detects an error, its basic display always shows the error. If either the solar yield or reheating function is possible, the controller carries out this function despite the error.

7 Sensor Characteristics

Cylinder sensors, type NTC 2.7 K

Sensor values	Resistance value
0 °C	9191 Ohm
5 °C	7064 Ohm
10 °C	5214 Ohm
20 °C	3384 Ohm
25 °C	2692 Ohm
30 °C	2158 Ohm
40 °C	1416 Ohm
50 °C	954 Ohm
60 °C	658 Ohm
70 °C	463 Ohm
80 °C	333 Ohm
120 °C	105 Ohm

Collector sensor, type NTC 10 K

Sensor values	Resistance value
-20 °C	97070 Ohm
-10 °C	55330 Ohm
-5 °C	42320 Ohm
0 °C	32650 Ohm
5 °C	25390 Ohm
10 °C	19900 Ohm
15 °C	15710 Ohm
20 °C	12490 Ohm
25 °C	10000 Ohm
30 °C	8057 Ohm
35 °C	6532 Ohm
40 °C	5327 Ohm
50 °C	3603 Ohm
60 °C	2488 Ohm
70 °C	1752 Ohm
80 °C	1258 Ohm
90 °C	918 Ohm
100 °C	680 Ohm
110 °C	511 Ohm
120 °C	389 Ohm
130 °C	301 Ohm

8 Control - Fault Finding

Error messages

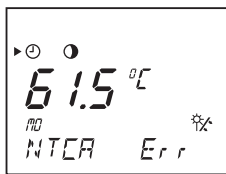
The Fluropro solar controller shows error messages in the main operating menu if there is a problem with the temperature sensor.

The sensor configuration will always be displayed when the controller is switched on for the first time, or if the power has been switched off and on again. Depending on the set hydraulic plan, the controller recognises whether there is a problem, or if the sensor is not necessary for operation.

The following diagrams assume that the day is Monday and that the timer is active for reheat but is not currently reheating.

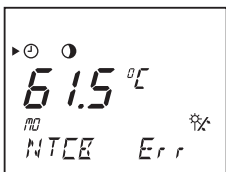
Error collector sensor (array 1)

This error occurs if there is a problem with the collector sensor, or if it is not connected.



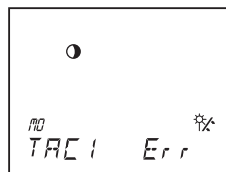
Error collector sensor (array 2)

This error occurs if a sensor is connected for hydraulic plan 1. Alternatively for hydraulic plan 2 or 3, if there is a problem with the connected sensor or it is not connected.



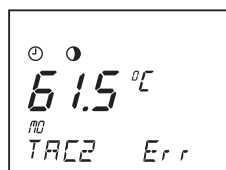
Error Upper cylinder sensor

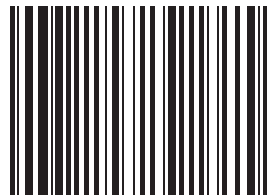
This error occurs if there is a problem with the heating circuit sensor connected.



Error Lower cylinder sensor

This error occurs if there is a problem with the solar circuit sensor, or if it is not connected.





0020055002

0020055002-04 03.09

Glow-worm, Nottingham Road, Belper, Derbyshire. DE56 1JT

Because of our constant endeavour for improvement, details may vary slightly from those shown in these instructions.