

**Glow·worm**

# Clearly Solar

## Solar Thermal Flat Plate Collector Installation Instructions

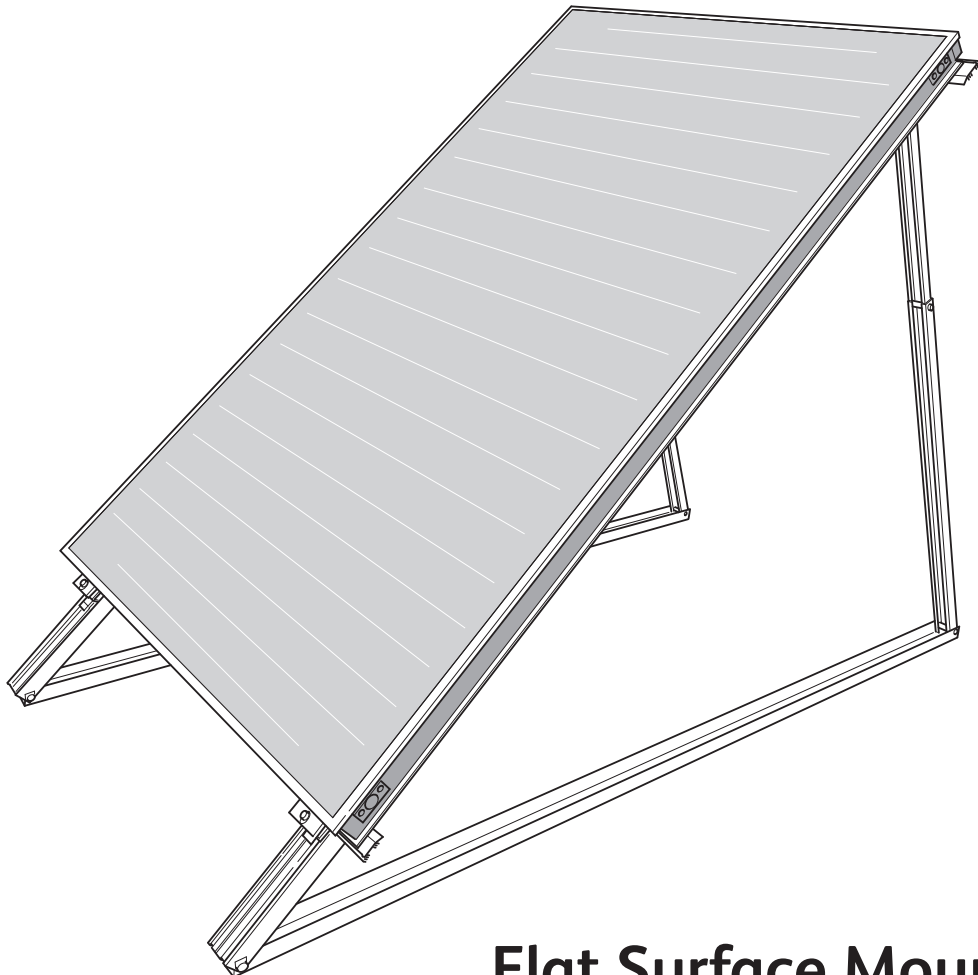

**Flat Surface Mounting  
SRH 2.3 and SRV 2.3**

# Guarantee Registration

---

These Clearly Solar Flat Plate collectors come with a comprehensive manufacturer's guarantee. Details of the guarantee, and the terms and conditions that apply can be found on the Guarantee registration card. We recommend you complete and return this as soon as possible.

## Customer Service:

01773 596510

## Technical Helpline:

01773 828300

## General and Sales enquiries:

Tel. 01773 824639

Fax: 01773 820569

## To register your Glow-worm appliance call:

0800 0732142

Benchmark places responsibilities on both manufacturers and installers. The purpose is to ensure that customers are provided with the correct equipment for their needs, that it is installed, commissioned and serviced in accordance with the manufacturer's instructions by competent persons and that it meets the requirements of the appropriate Building Regulations. The Benchmark Checklist can be used to demonstrate compliance with Building Regulations and should be provided to the customer for future reference.

Installers are required to carry out installation, commissioning and servicing work in accordance with the Benchmark Code of Practice which is available from the Heating and Hotwater Industry Council who manage and promote the Scheme.

Visit [www.centralheating.co.uk](http://www.centralheating.co.uk) for more information.



These instructions must be handed to the user on completion of the installation.

CONTENTS	DESCRIPTION	SECTION	PAGE
<b>GENERAL INFORMATION</b>	Warnings		4
	Important Information		4
	Statutory Requirements		5
<b>TECHNICAL SPECIFICATION</b>	Technical Specification	1	6
<b>FLAT SURFACE MOUNTING</b>	Vertical Collector Technical Data	2	7
	Vertical Collector and Hydraulic Connection Arrangement	3	8
	Hydraulic Connection Kits - Vertical Collector	4	9
	Flat Surface Installation - Vertical Collector	5	10
	Horizontal Collector Technical Data	6	17
	Horizontal Collector and Hydraulic Connection Arrangement	7	18
	Hydraulic Connection Kits - Horizontal Collector	8	19
	Flat Surface Installation - Horizontal Collector	9	20

# WARNINGS

## **Metal Parts**

This solar panel contains metal parts (components) and care should be taken when handling, with particular regard to edges.

## **Risk of death from falls and falling objects**

Observe the national regulations for working at heights.

## **Danger of burning and scalding**

In case of solar irradiation inside the units, solar panels can reach 200°C.

Remove the sun protection film installed at the factory only after the solar energy system has been started up.

## **Sealed Components**

Under no circumstances must the user interfere with or adjust sealed parts.

## Important Information

### **General**

These instructions must be handed to the user on completion of the installation.

This installation instruction applies exclusively to the mounting of the solar collector.

The solar collector is one component in a solar system and it is recommended that you read all other component(s) literature prior to installation.

We accept no liability for any damage caused by failure to observe these instructions.

### **Control of Substances Hazardous to Health**

Under Section 6 of The Health and Safety at Work Act 1974, we are required to provide information on substances hazardous to health.

The adhesives and sealants used in this appliance are cured and give no known hazard in this state.

### **Solar fluid**

For solar fluid safety data, please refer to Clearly Solar System Hydraulics literature.

### **Manual Handling**

With regards to the "Manual Handling Operations, 1992 Regulations", this product exceeds the recommended weight for a one man lift.

Recommend 2 person lift. Ensure safe lifting techniques are used – keep back straight – bend using legs. Keep load as close to body as possible. Ensure co-ordinated movements during lift. Clear the route before attempting the lift. If removing from truck straddle the load and tilt forwards to facilitate secure grip. Do not twist – reposition feet instead. Take care to avoid trip hazards, slippery or wet surfaces and when climbing steps or ladders. Always use assistance if required.

Installation of the solar collector will require a risk assessment.

### **Testing and Certification**

This solar collector is tested and certificated for safety and performance. It is, therefore, important that no alteration is made, without permission, in writing, by Glow-worm.

Any alteration not approved by Glow-worm, could invalidate the certification, warranty and may also infringe the current issue of the statutory requirements.

### **CE Mark**

The CE mark on the solar collector indicates that it complies with the basic requirements of the applicable directives as stated on the data label.

### **Damage from lightning**

If the installation height is more than 20m, electro-conductive components must be connected to a lightning protection device.

### **Frost Protection**

Under no circumstances should water be in the solar collector if there is a danger of frost.

After pressurisation and flushing, the solar collector(s) may contain water residue.

Water remaining in the solar circuit will dilute the fluid.

Immediately fill the solar system with solar fluid. Check the fluid concentration with a frost protection tester.

# Statutory Requirements

## IMPORTANT

Where no British Standards exists, materials and equipment should be fit for their purpose and of suitable quality and workmanship.

The installation of this solar collector panel must be carried out by a **competent person** in accordance the rules in force in the countries of destination.

Manufacturer's instructions must not be taken as overriding statutory requirements.

## Statutory Requirements

In GB, the installation of the solar collector panel must comply with the requirements of the current issue of the following regulations:

The manufacturer's instructions supplied.

The appropriate Buildings Regulations either The Building Regulations, The Building Regulations (Scotland), The Building Regulations (Northern Ireland).

Working at Heights Regulations 2005.

Connecting thermal solar appliances.

Lightning protection requirements.

Equipotential bonding of electrical installations.

The Health and Safety at Work Act

Control of Substances Hazardous to Health (COSHH).

The Current I.E.E. Wiring Regulations.

The Water Supply (water fittings) Regulations 1999 or the Water Byelaws 2000 (Scotland).

Where no specific instructions are given, reference should be made to the relevant British Standard Code of Practice.

## Regulations for the prevention of accidents

At all times follow the national regulations on working at heights.

Make sure there is suitable safety equipment such as scaffolding or protective walls to prevent falling from roofs.

Fall protection systems such as the Glow-worm fall protection system (item no. 0020054985) also has a fall arresting device if the roof scaffold and protective roof wall are inappropriate for the specific task.

Only use tools and equipment such as lifting gear or ladders in accordance with the lifting regulations.

Cordon off areas below the working area sufficiently to protect people from falling objects.

Mark the working area, for example with warning signs as described by the national regulations.

# 1 Technical Specification

## Design Description

The Clearly Solar, solar flat plate collector, collects the available solar radiation and transfers the heat through the solar fluid to be utilised by the system.

It has been designed to compliment the complete range of Glow-worm solar system components.

The kits are suitable for flat roof or flat surface installation.

The solar thermal flat plate collector includes a saltwater-resistant aluminium frame as well as a copper surface absorber with a high selective coating.

The flat plate collector has a CFC-free, standstill temperature-resistant mineral wool insulation for long-life and excellent heat insulation.

Hydraulic connections are tool free with double 'O' ring sealing. The sensor sleeve is integrated into the hydraulic flow connection.

Hydraulic connections are push-fit with double 'O' ring sealing. The sensor sleeve is integrated into the hydraulic flow connection.

**IMPORTANT:** The completed works shall comply with all necessary BS EN Standards and Codes of practice as well as Building control or planning requirements, these should be confirmed where necessary by notification to building control or the appropriate competence based notification body.

The following kits are available and dependant upon the number of collectors, the quantities required are listed in the following table and illustrated in the appropriate sections:-

		Number of collectors:											
		1	2	3	4	5	6	7	8	9	10	11	12
Vertical collector position	Gravel tray Part number 0020059905	2	3	4	5	6	7	8	9	10	11	12	13
	Easy fit hydraulic connection set - Section 4. Part number 0020060207	1											
	Easy fit hydraulic extension set - Section 4. Part number 0020059909	-	1	2	3	4	5	6	7	8	9	10	11
	Vertical frame Part number 0020060312 Diagram 5.1.	2	3	4	5	6	7	8	9	10	11	12	13
	Vertical rail, aluminium Part number 0020060308 - Diagram 5.1.	2	4	6	8	10	12	14	16	18	20	22	24
Horizontal collector position	Gravel tray art.-no. 0020059904	2	3	4	5	6	7	8	9	10	11		
	Easy fit hydraulic connection set - Section 4. Part number 0020060207	1											
	Easy fit hydraulic extension set - Section 4. Part number 0020059909	-	1	2	3	4	5	6	7	8	9		
	Horizontal frame Part number 0020060311 Diagram 9.1.	2	3	4	5	6	7	8	9	10	11		
	Horizontal rail, aluminium Part number 0020060307 - Diagram 9.1.	1	2	3	4	5	6	7	8	9	10		

Flat surface installation components

## 2 Vertical Collector Technical Data

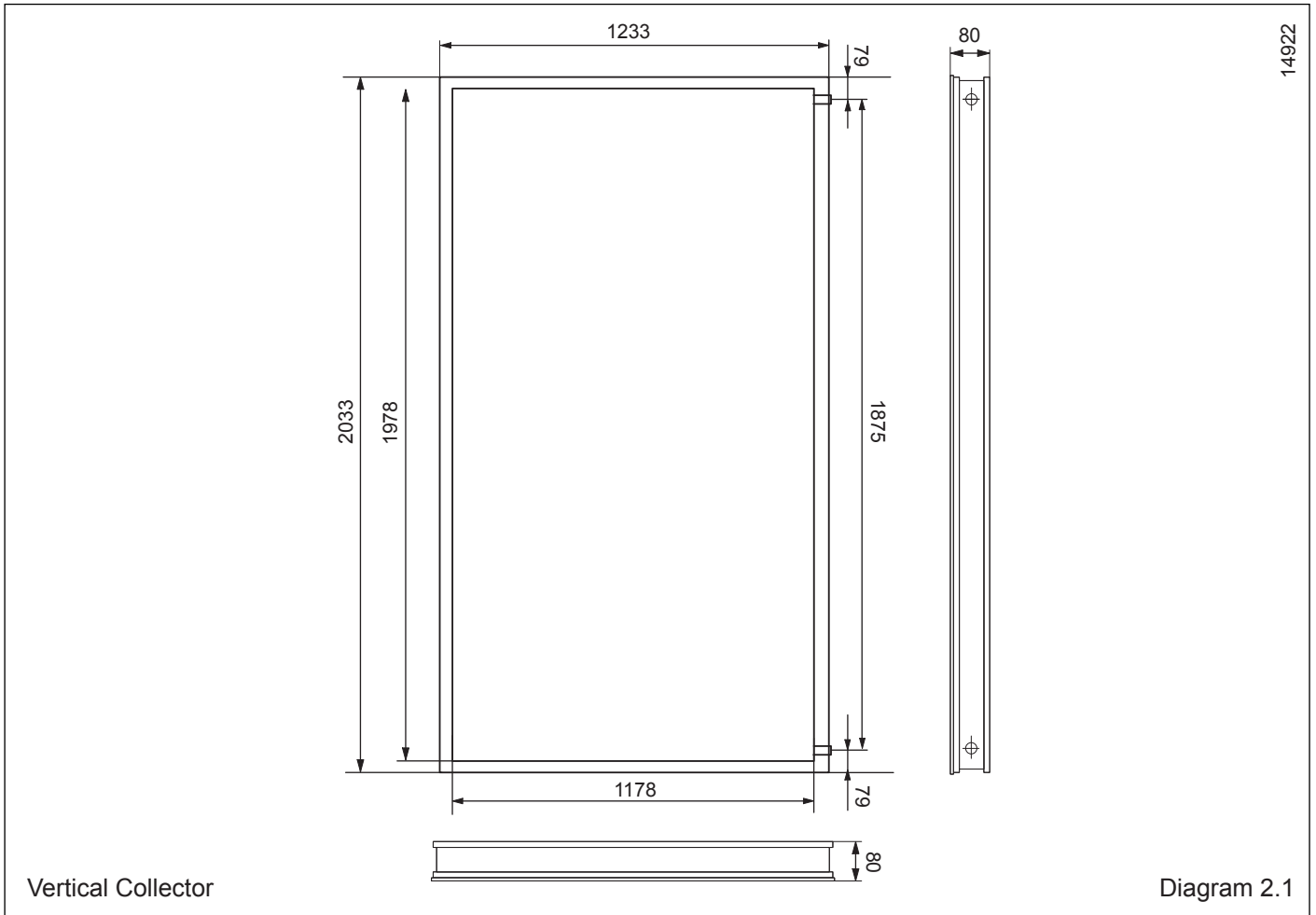

Appliance designation	Unit.	Clearly Solar	
Absorber type		Serpentine	
Gross area	m <sup>2</sup>	2.51	
Aperture surface area	m <sup>2</sup>	2.35	
Absorber surface area	m <sup>2</sup>	2.33	
Absorber		Aluminium (vacuum coated) 0.5 x 1178 x 1978	
Dimensions (L x W x H)	mm	2033 x 1233 x 80	
Weight (Dry)	kg	38	
Fluid content	l	1.85	
Copper pipe connection, flat-face	Ø mm	G 3/4" (DN16)	
Insulation thickness	mm	40	
Max. operating pressure	bar	10	
Glass type		Solar safety glass (prismatic structure)	
Glass covering	mm	3.2 (thickness) x 1233 x 2033	
Coating		High selective (blue)	$\alpha = 95\%$ $\epsilon = 5\%$
Transmission	%	$\tau = 91$	
Back wall insulation	mm, W/m <sup>2</sup> K, kg/m <sup>3</sup>	40 $\lambda = 0.035$ $\rho = 55$	
Stagnation temperature	°C	210	
Efficiency $\eta_0$	%	80	
Heat capacity	Ws/m•K	5014	
Heat loss factor $k_1$	W/m <sup>2</sup> •K	3.7	
Heat loss factor $k_2$	W/m <sup>2</sup> •K <sup>2</sup>	0,012	

# 3 Vertical Collector and Hydraulic Connection Arrangement

## Collector Panel

The recommended collector panel arrangements are shown below.

## Hydraulic Connections

It is recommended that the hydraulic connections should be made as shown below.

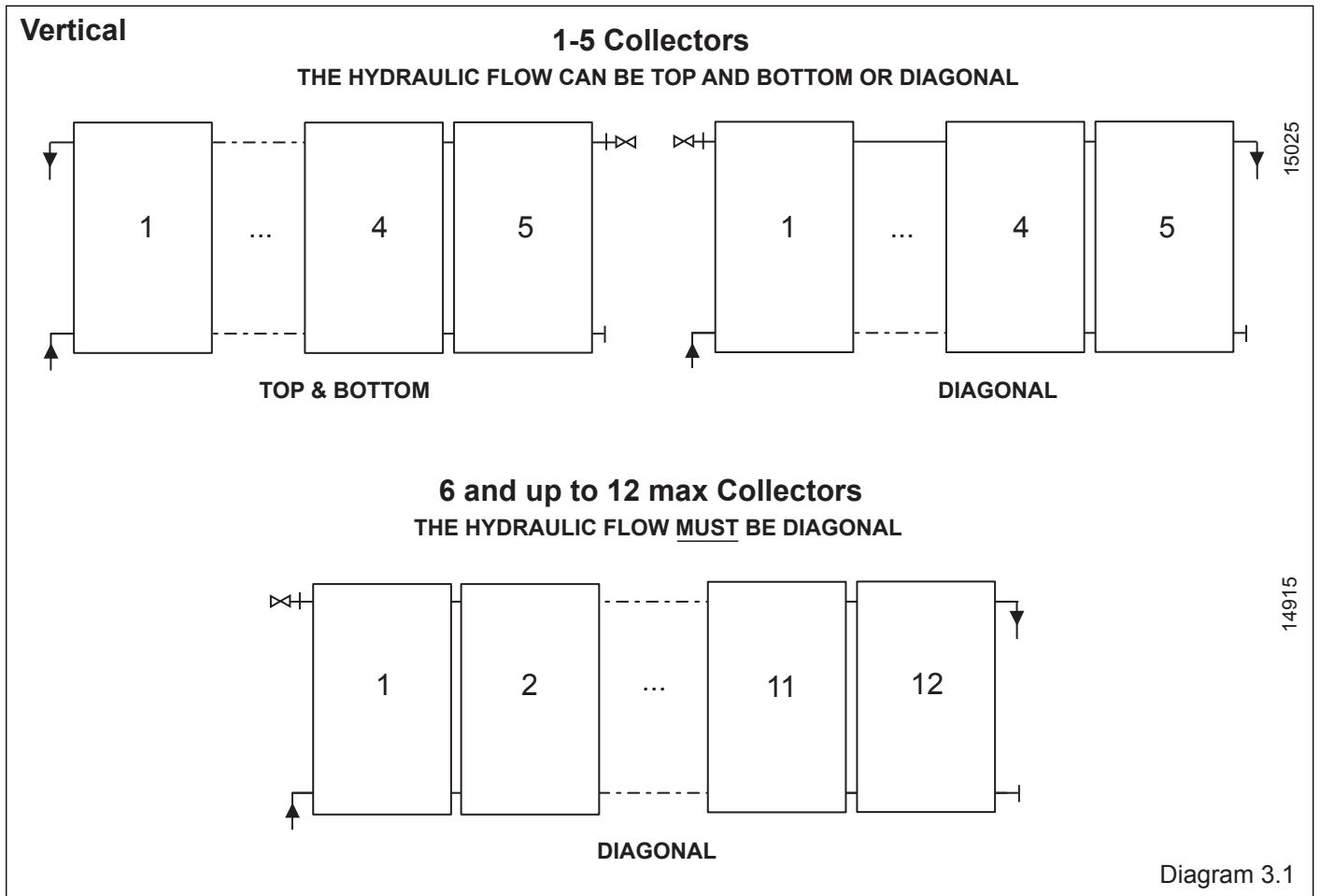



# 4 Hydraulic Connection Kits - Vertical Collector

15303

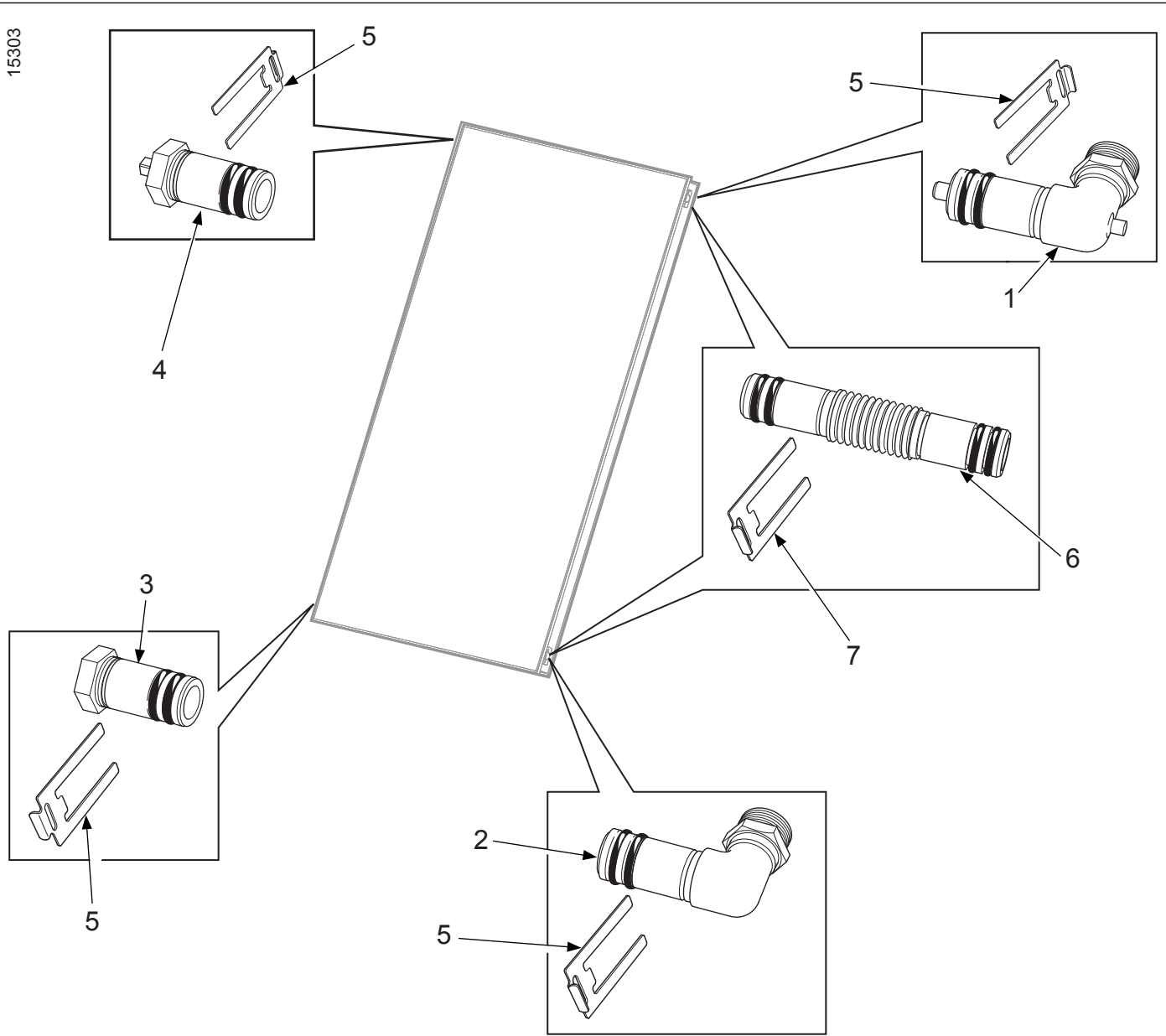

Easy fit hydraulic connection set - Part No. 0020060207		
Part	Description	Qty.
1	Upper supply (with probe)	1
2	Return (inlet)	1
3	Lower plug	1
4	Upper plug (with ventilation)	1
5	Securing clip	4
Easy fit hydraulic extension set - Part No. 0020059909		
Part	Description	Qty.
6	Pipe coupling	2
7	Securing clip	4

Diagram 4.1

## 5 Flat Surface Installation - Vertical Collector

14998

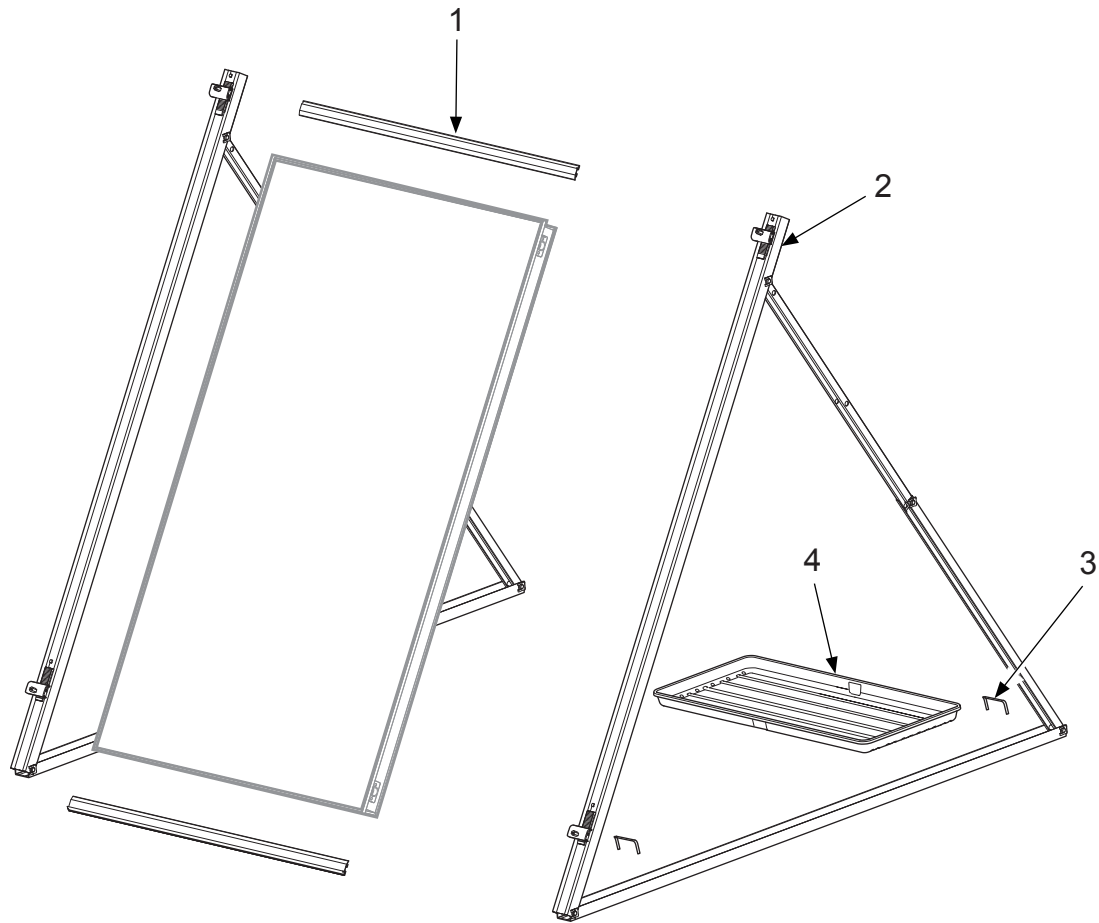

Flat surface mounting kit		
Part	Description	Qty.
1	Mounting rail	2
2	Frame with clamping assembly	1
3	Safety clamp	2
4	Gravel tray (optional)	2-3

Flat Surface Mounting Kit

Diagram 5.1

# 5 Flat Surface Installation - Vertical Collector

## 5.1 Flat surface installation

### IMPORTANT

- Do not remove the protection film until the system is to be commissioned.
- With due regard to the complete weight of the solar collector system, (refer to technical data) ensure the surface is flat and has a sufficient load carrying capacity.
- Ensure that a roof surface is adequately protected and watertight.

The flat surface frames allow the collectors to be installed at an angle of 30°, 45° or 60°. The mounting rails can be adjusted to compensate for floor irregularities.

## 5.2 Ballast and frame weight

Define the necessary load required to secure the frame and collector, refer to Table 5.1. For the required space and the distances among collectors, refer to Table 5.2.

Angle	Height above ground		
	0-10 m	10-18 m	18-25 m
30°	159 Kgs	178 Kgs	197 Kgs
45°	225 Kgs	252 Kgs	279 Kgs
60°	276 Kgs	309 Kgs	342 Kgs

Table 5.1

Number of collectors	A	30°		45°		60°		C	D	A
		B	F	B	F	B	F			
1*	1136								-	-
2	2300									
3	3563									
4	4826									
5	6089									
6	7352	1283	4400	1740	6100	2080	7200	2357	1150	1263
7	8615									
8	9878									
9	11141									
10	12404									

\* Possible only with 4 offset gravel trays.

Table 5.2

# 5 Flat Surface Installation - Vertical Collector

## 5.3 Collector Installation

**NOTE:** Roof installation

With due regard to the complete weight of the ballast, frame, collector and system, proceed as follows:

With the floor section secured (screwed or gravel trays) to the flat surface, fix the lower telescopic section with retaining pin and safety clip, see diagram 5.2.

**NOTE:** If gravel trays are used, slide the gravel tray onto the floor section before fixing the lower telescopic section, see diagram 5.3.

Apply the safety clamps from the top floor sections (2x frame) to fix the gravel tray.

Collectors should have 3 gravel trays per frame.

Extend the telescopic sections until the hole of the desired position is aligned, then secure with retaining pin and safety clip, see diagram 5.4.

You can choose 30°, 45° or 60°, the standard is 45°.

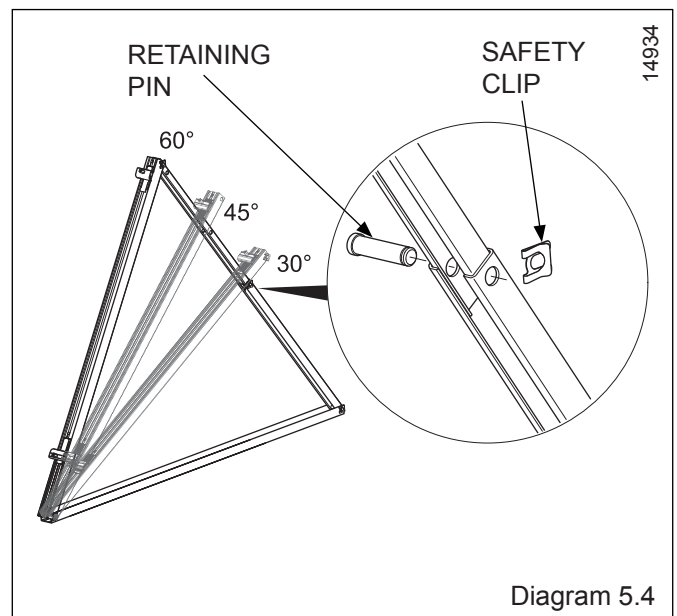
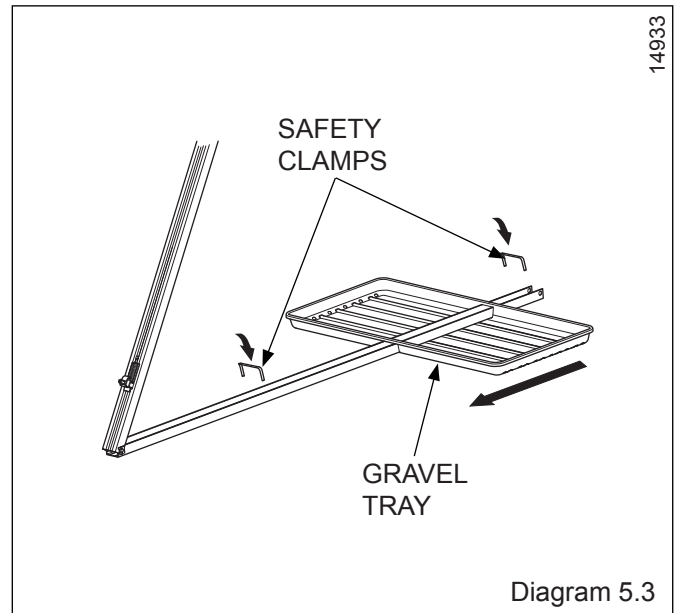
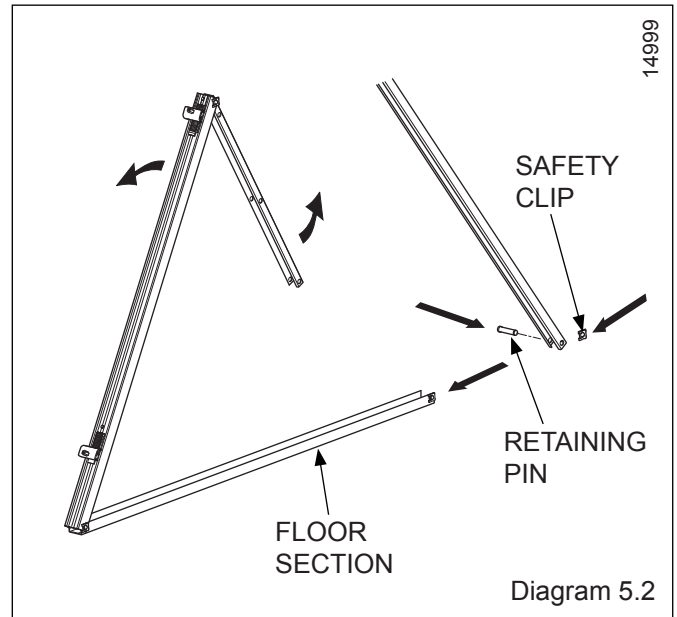

## 5 Flat Surface Installation - Vertical Collector

Fix the lower mounting rail with the frame clamping assembly, see diagram 5.5.

If multiple collectors are mounted, the mounting rails meet in the centre of the clamping assemblies, see diagram 5.6.

On the first and last frame, the mounting rails can be projected by 20mm.

Insert the mounting rail connector into the mounting rails, see diagram 5.6

Position another frame (see diagrams 5.1 to 5.3).

Join the mounting rails and fix them to the frame clamping assemblies as shown in diagram 5.7.

Compensate any difference in height by moving the clamping assembly.

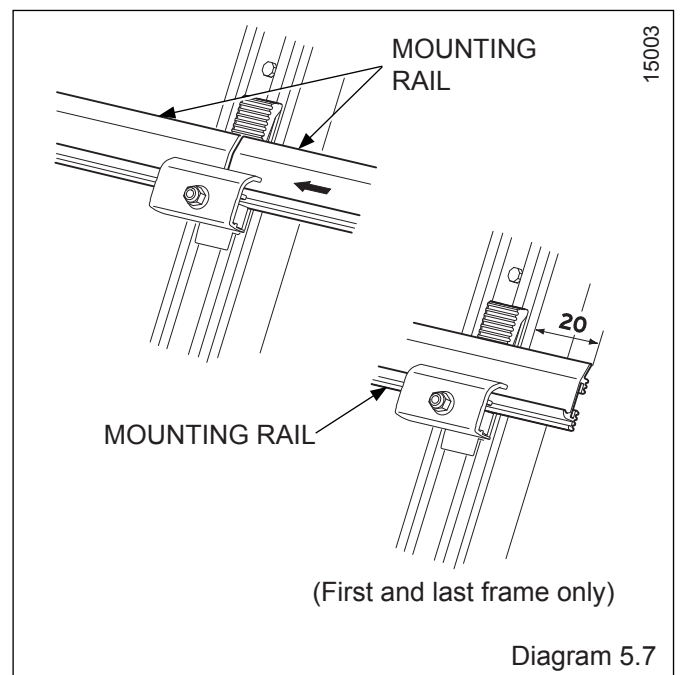
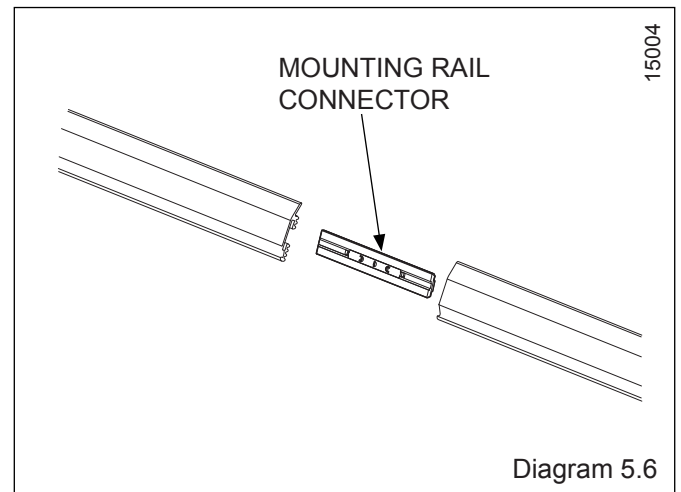
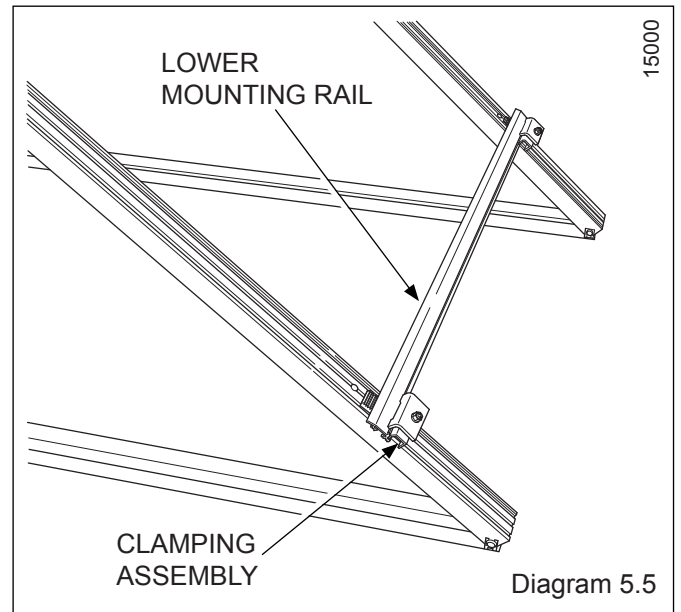

## 5 Flat Surface Installation - Vertical Collector

Place the collector with the lower edge in the section of the mounting rail, see diagram 5.8.  
Make sure that the upper part of the clamping assembly is above the collector edge.

Slide the upper mounting rail until it is flush with the collector.  
Make sure that the upper part of the clamping assembly is above the collector edge, see diagram 5.9.

Tighten the lower clamping assemblies with the socket/  
combination wrench (SW13).

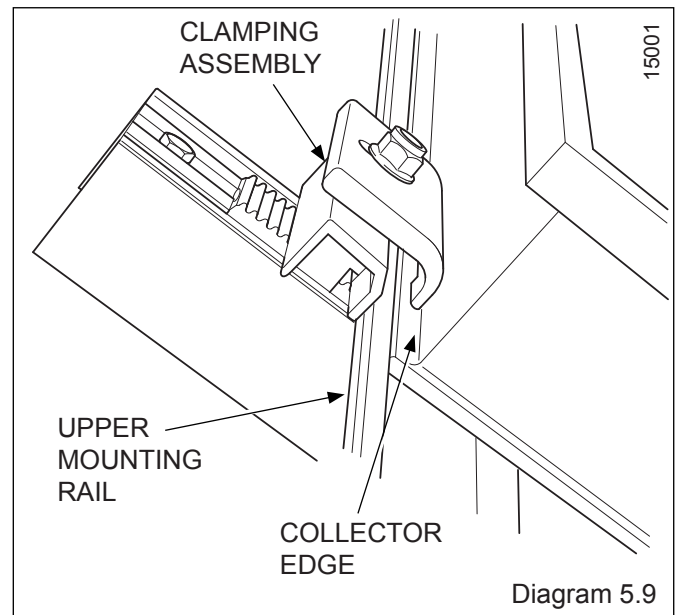
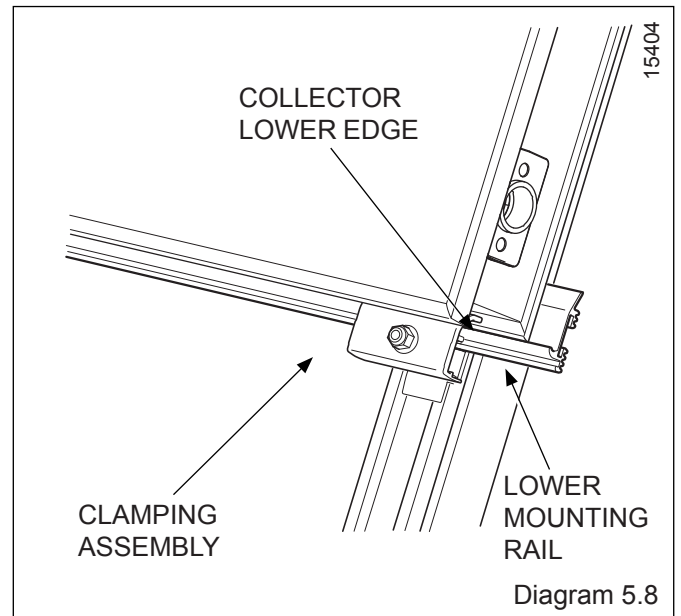

## 5 Flat Surface Installation - Vertical Collector

Remove the plugs from the openings of the collector and insert the pipe couplings up to their stops, see diagram 5.10. Slide the retaining clips into place to secure the pipe couplings.

**NOTE:** The collector design is symmetrical and does not have a top or bottom.

Place the next collector on the lower mounting rail and slide towards the first collector. Secure the pipe couplings to the second collector with the securing clips. Tighten the clamping assemblies of the first collector with the socket/ combination wrench (SW13).

With regards to the hydraulic system you have chosen, insert and secure the hydraulic connections, see diagram 5.9.

Insert the collector sensor into the appropriate elbow (flow, top), see diagram 5.11. The collector sensor is packed with the Fluropro controller, part no. 0020054960.

Mount the plug with the bleed valve (vent) in the opposite top position.

Connect the collector to the system circuit.

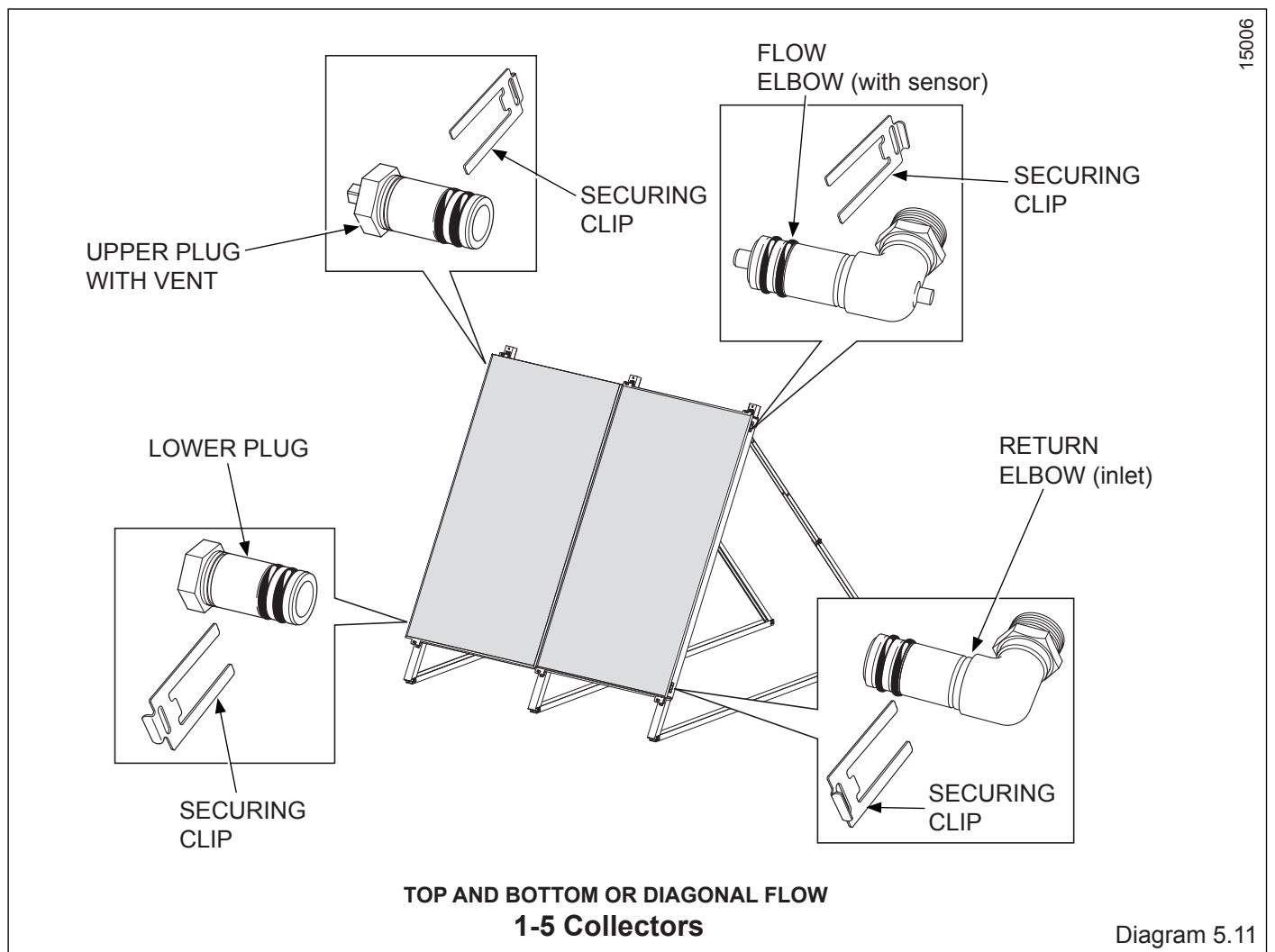
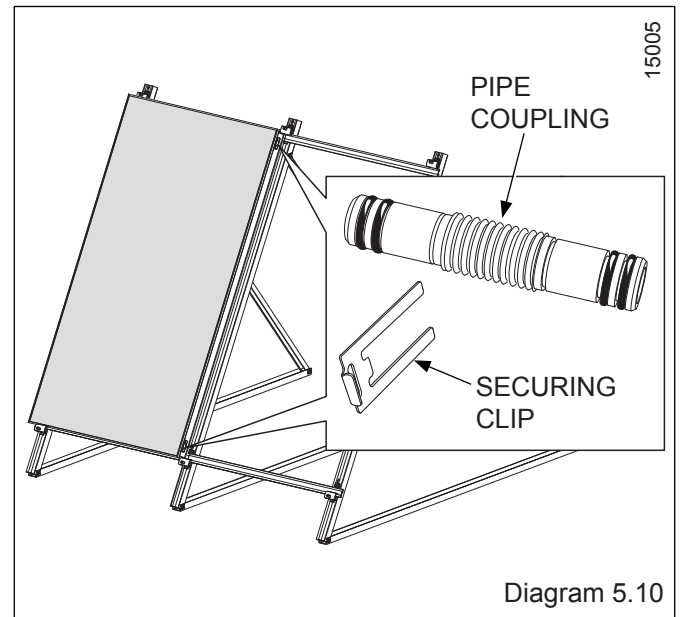

## 5 Flat Surface Installation - Vertical Collector

Ensure that all of the following steps have been performed:-

- All the connections have been fixed with securing clips.
- All hydraulic connections laid properly.
- The collector sensor has been connected.
- The collector is connected to a lightning protection device.
- A pressure test.
- All insulation is intact.

**NOTE:** After initial commissioning and according to the season, high outside temperature oscillations can cause condensation in the collector, this is normal.

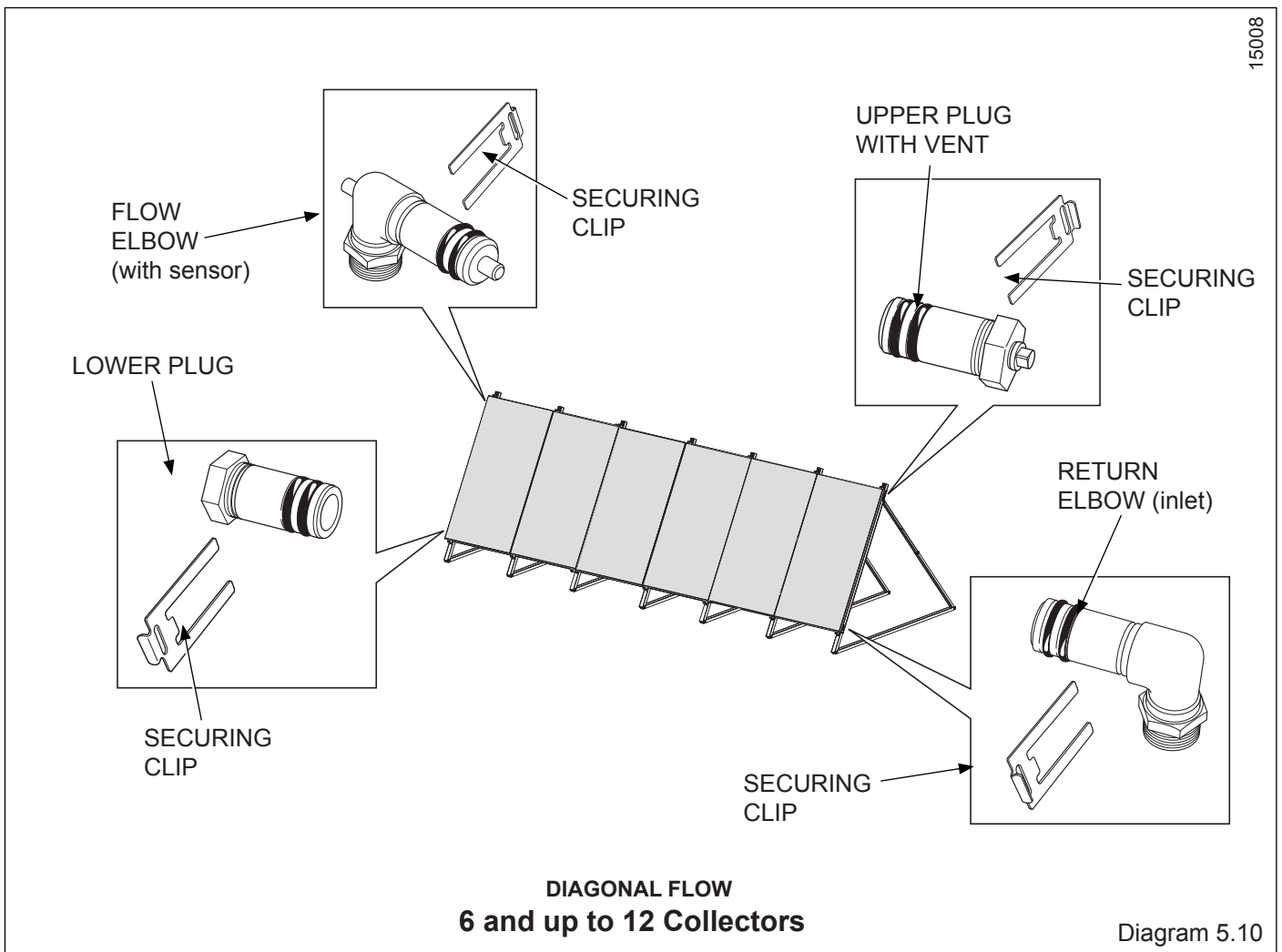



## 6 Horizontal Collector Technical Data

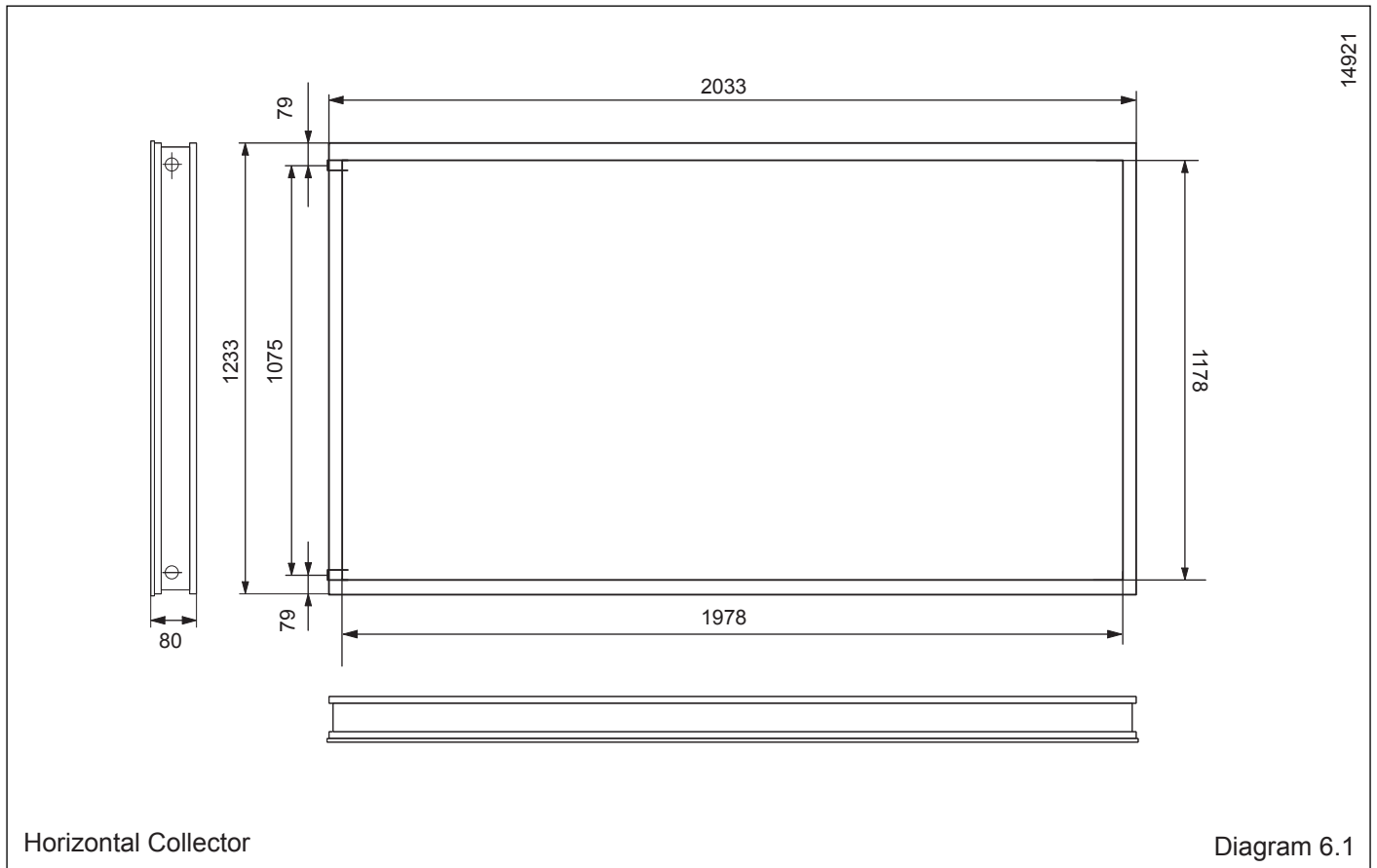

14921

Appliance designation	Unit.	<b>Clearly Solar</b>	
Absorber type		Serpentine	
Gross area	m <sup>2</sup>	2.51	
Aperture surface area	m <sup>2</sup>	2.35	
Absorber surface area	m <sup>2</sup>	2.33	
Absorber		Aluminium (vacuum coated) 0.5 x 1178 x 1978	
Dimensions (L x W x H)	mm	1233 x 2033 x 80	
Weight (Dry)	kg	38	
Fluid content	l	2.16	
Copper pipe connection, flat-face	Ø mm	G 3/4" (DN16)	
Insulation thickness	mm	40	
Max. operating pressure	bar	10	
Glass type		Solar safety glass (prismatic structure)	
Glass covering	mm	3.2 (thickness) x 2033 x 1233	
Coating		High selective (blue)	$\alpha = 95\%$ $\varepsilon = 5\%$
Solar safety glass transmission $\tau$ (dew)	%	$\tau = 91$	
Absorber emission $\varepsilon$ (epsilon)	%	$5 \pm 2$	
Back wall insulation	mm, W/mk, kg/m	$95 \pm 2$	
Stagnation temperature	°C	210	
Efficiency $\eta_0$	%	80	
Heat capacity	Ws/ (m•K)	5014	
Efficiency coefficient k1	W/(m <sup>2</sup> •K)	3.7	
Efficiency coefficient k2	W/(m <sup>2</sup> •K <sup>2</sup> )	0,012	

# 7 Horizontal Collector and Hydraulic Connection Arrangement

## Collector Panel

The recommended collector panel arrangements are shown below.

## Hydraulic Connections

It is recommended that the hydraulic connections should be made as shown below.

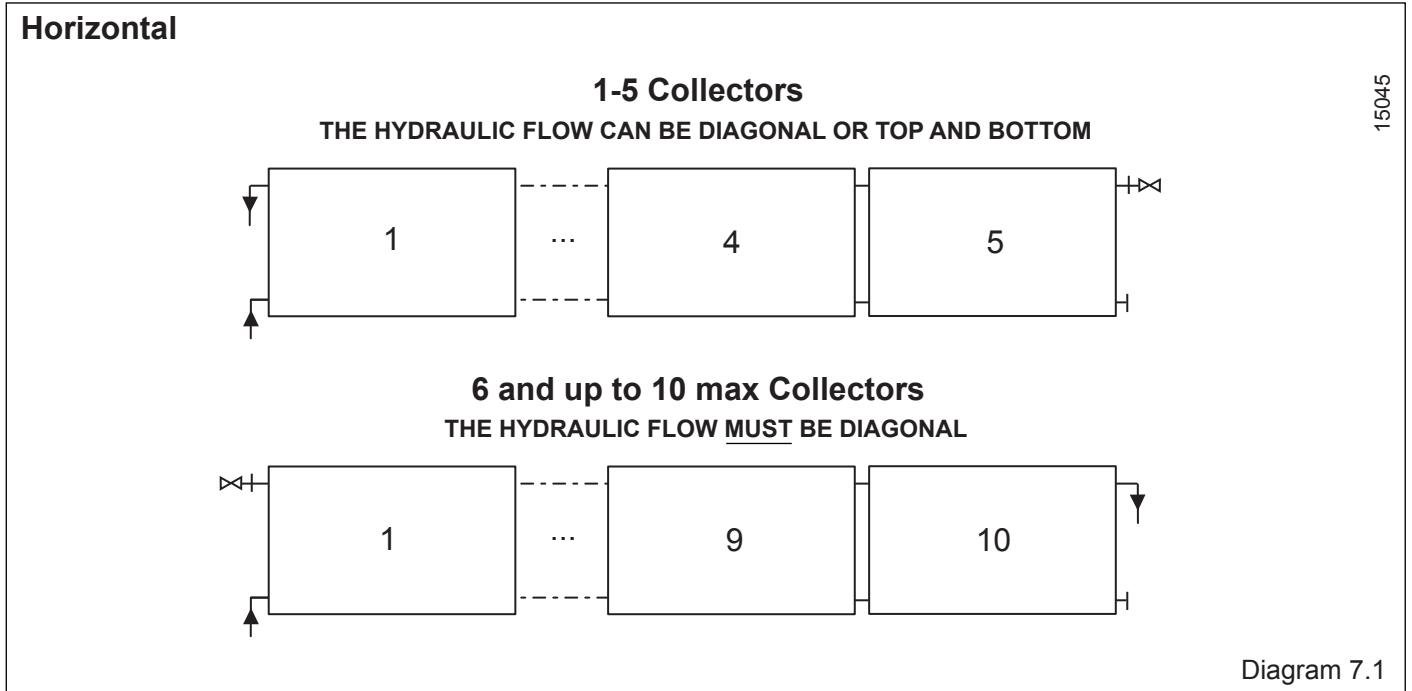

# 8 Hydraulic Connection Kits - Horizontal Collector

15305

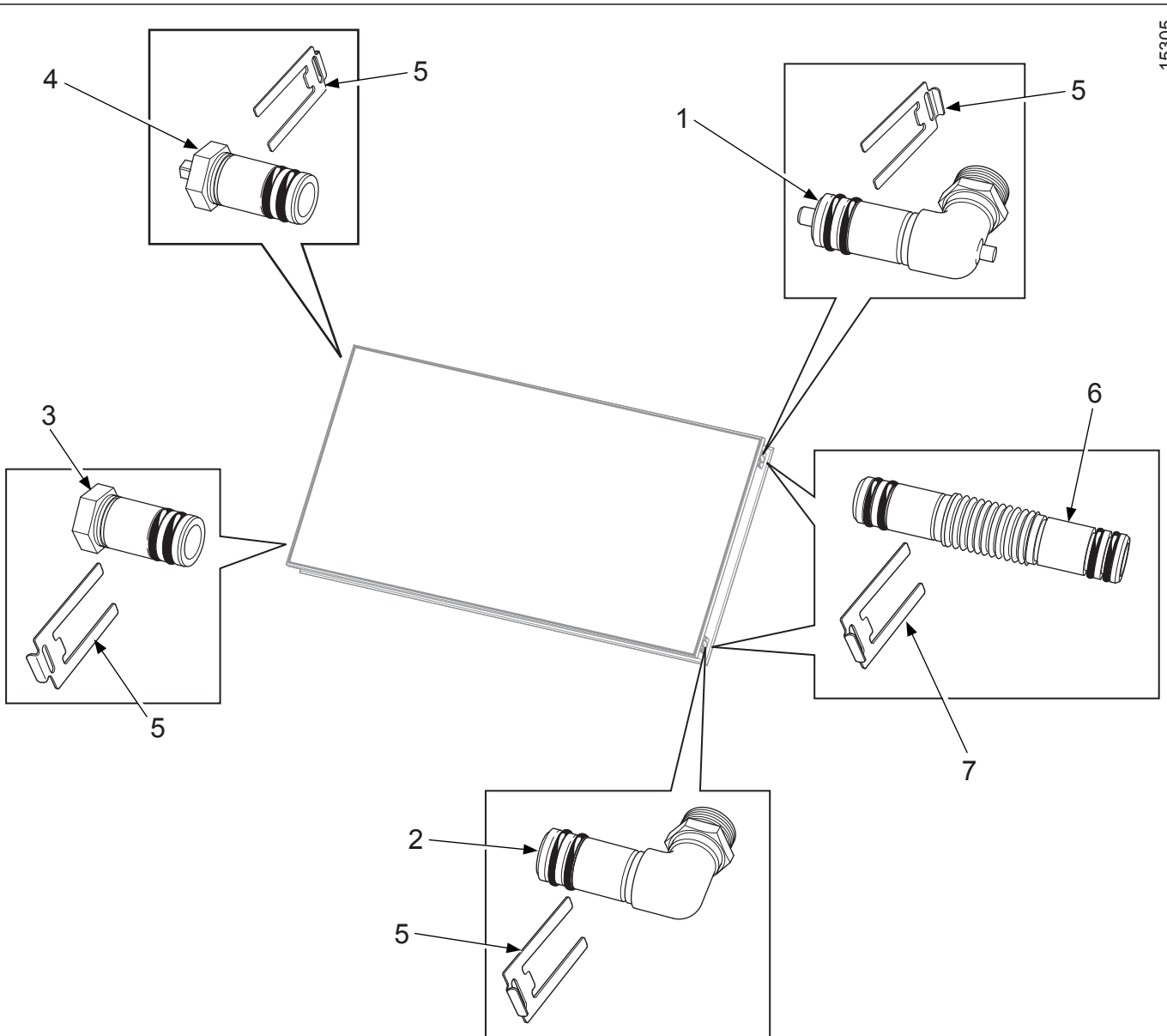

Easy fit hydraulic connection set - Part No. 0020060207		
Part	Description	Qty.
1	Upper supply (with probe)	1
2	Return (inlet)	1
3	Lower plug	1
4	Upper plug (with ventilation)	1
5	Securing clip	4
Easy fit hydraulic extension set - Part No. 0020059909		
6	Pipe coupling	2
7	Securing clip	4

Diagram 8.1

# 9 Flat Surface Installation - Horizontal Collector

15136

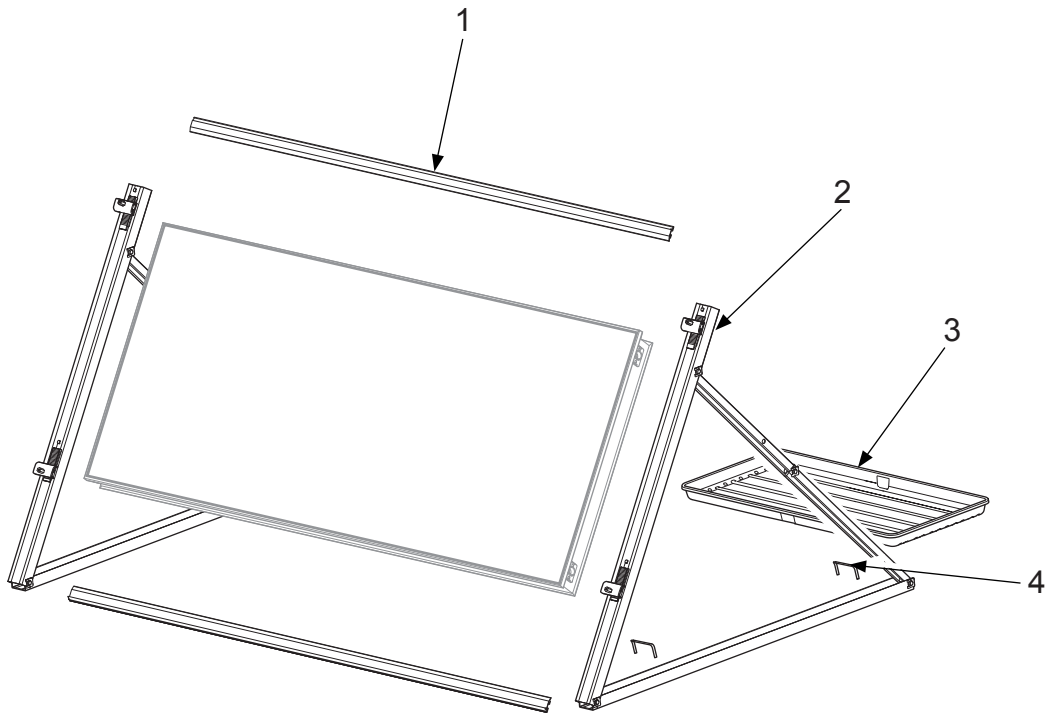

On-roof mounting kit		
Part	Description	Qty.
1	Mounting rail	2
2	Frame with clamping element	1
3	Gravel tray (optional)	2-3
4	Safety clamps	2

Flat Surface Mounting Kit

Diagram 9.1

# 9 Flat Surface Installation - Horizontal Collector

## 9.1 Flat surface installation

### IMPORTANT

- Do not remove the protection film until the system is to be commissioned.
- With due regard to the complete weight of the solar collector system, (refer to technical data) ensure the surface is flat and has a sufficient load carrying capacity.
- Ensure that a roof surface is adequately protected and watertight.

The flat surface frames allow the collectors to be installed at an angle of 30°, 45° or 60°.

The mounting rails can be adjusted to compensate for floor irregularities.

## 9.2 Ballast and frame weight

Define the necessary load required to secure the frame and collector, refer to Table 9.1.

For the required space and the distances among collectors, refer to Table 9.2.

Angle	Height above ground		
	0-10 m	10-18 m	18-25 m
30°	159	178	197
45°	225	252	279
60°	276	309	342

Table 9.1

Number of collectors	A	30°		45°		60°		C	D	E
		B	F	B	F	B	F			
1*	1650								-	-
2	3900									
3	5963									
4	8026									
5	10089	883	3100	1173	4100	1387	4800	1812	1950	2063
6	12152									
7	14215									
8	16278									
9	18341									
10	20404									

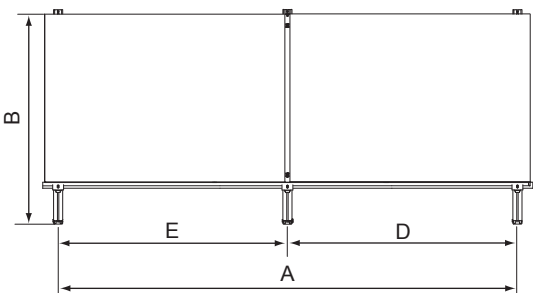
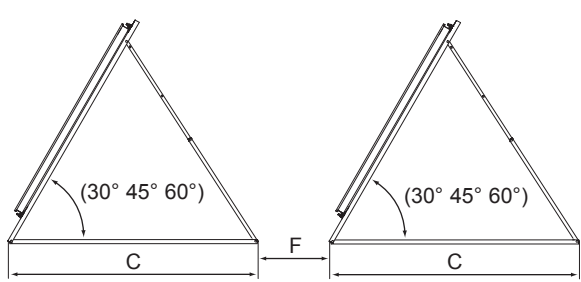
\* Possible only with 4 offset gravel trays.

Table 9.2

# 9 Flat Surface Installation - Horizontal Collector

## 9.3 Collector Installation

**NOTE:** Roof installation

With due regard must to the complete weight of the ballast, frame, collector and system, proceed as follows:

With the floor section secured (screwed or gravel trays) to the flat surface, fix the lower telescopic section with retaining pin and safety clip, see diagram 9.1.

**NOTE:** If gravel trays are used, slide the gravel tray onto the floor section before fixing the lower telescopic section, see diagram 9.2.

Apply the safety clamps from the top floor sections (2x frame) to fix the gravel tray.

Collectors should have 3 gravel trays per frame.

Extend the telescopic sections until the hole of the desired position is aligned, then secure with retaining pin and safety clip, see diagram 9.3.

You can choose 30°, 45° or 60°, the standard is 45°.

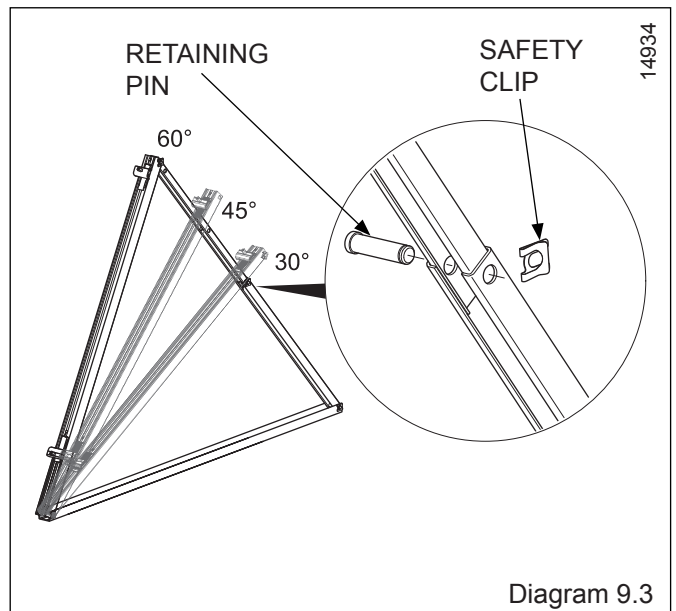
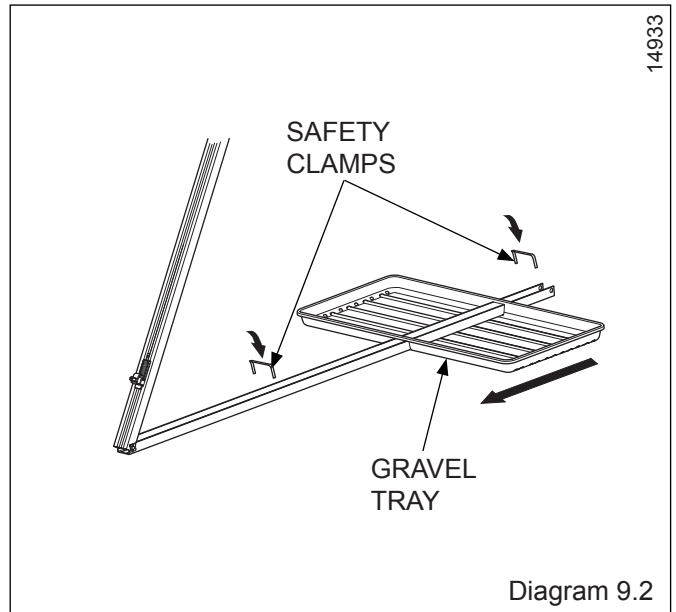
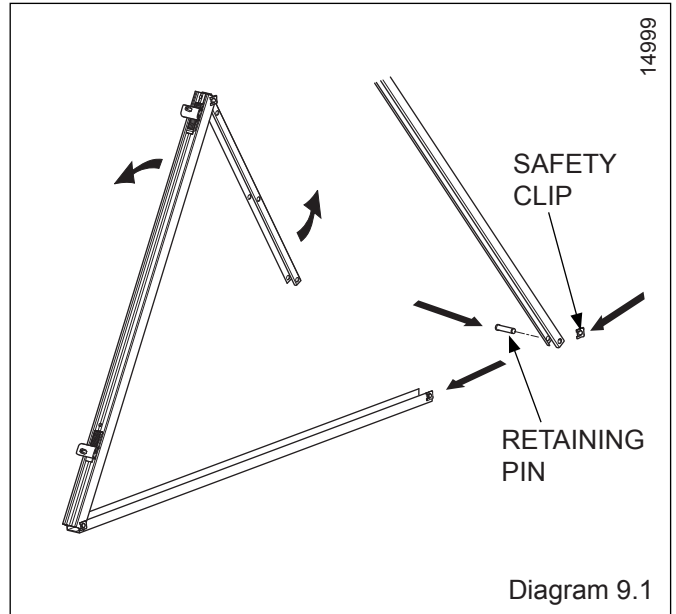

# 9 Flat Surface Installation - Horizontal Collector

Fix the lower mounting rail with the frame clamping assembly, see diagram 9.4.

If multiple collectors are mounted, the mounting rails meet in the centre of the clamping assemblies, see diagram 5.5. On the first and last frame, the mounting rails can be projected by 20mm. Insert the mounting rail connector into the mounting rails, see diagram 9.5. Position another frame (see diagrams 9.1 to 9.3). Join the mounting rails and fix them to the frame clamping assemblies as shown in diagram 9.6. Compensate any difference in height by moving the clamping assembly.

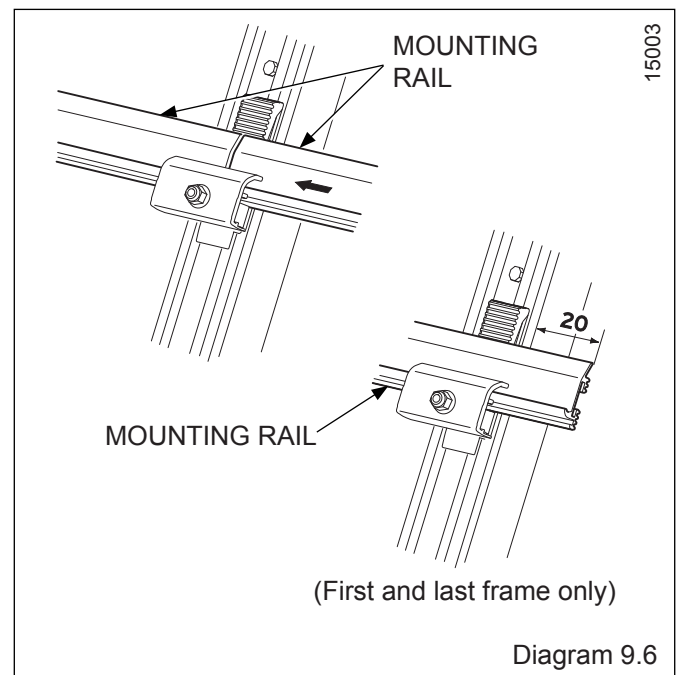
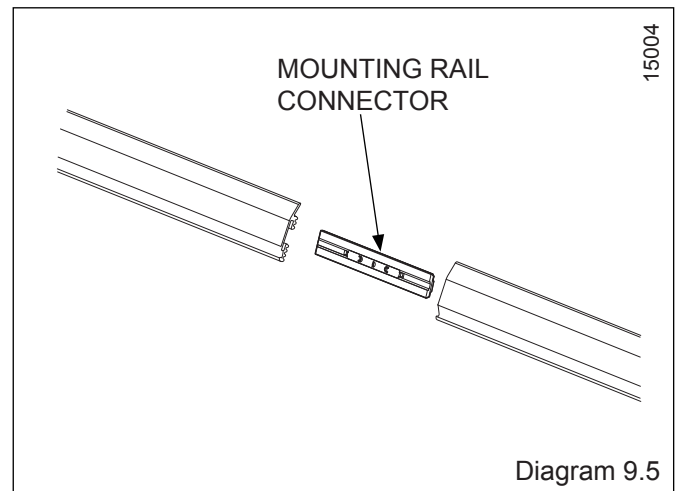
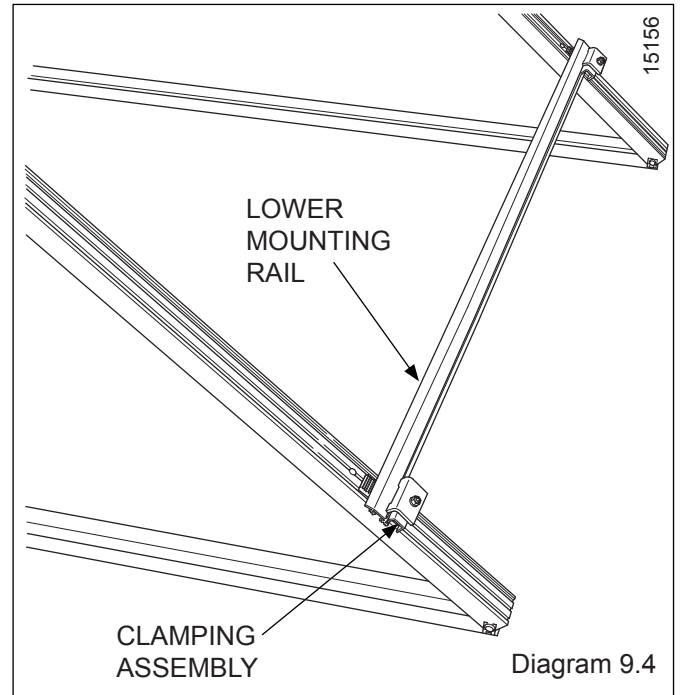

## 9 Flat Surface Installation - Horizontal Collector

Place the collector with the lower edge in the section of the mounting rail, see diagram 9.7.  
Make sure that the upper part of the clamping assembly is above the collector edge.

Slide the upper mounting rail until it is flush with the collector.  
Make sure that the upper part of the clamping assembly is above the collector edge, see diagram 9.8.

Tighten the lower clamping assemblies with the socket/  
combination wrench (SW13).

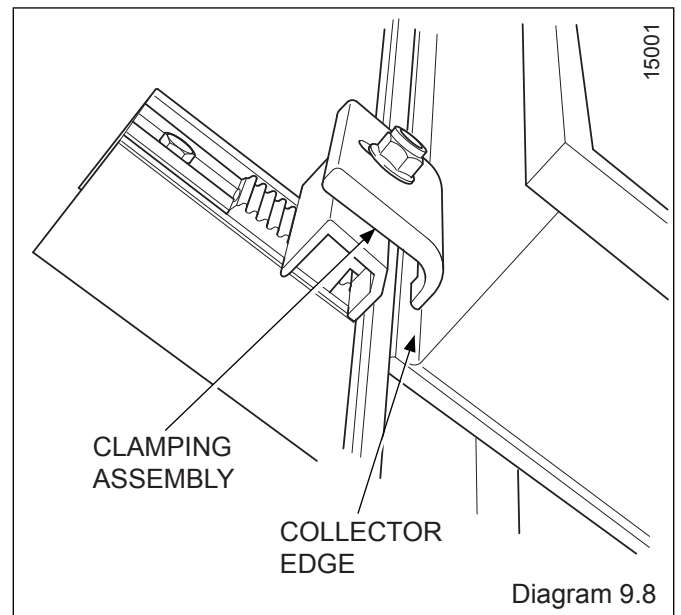
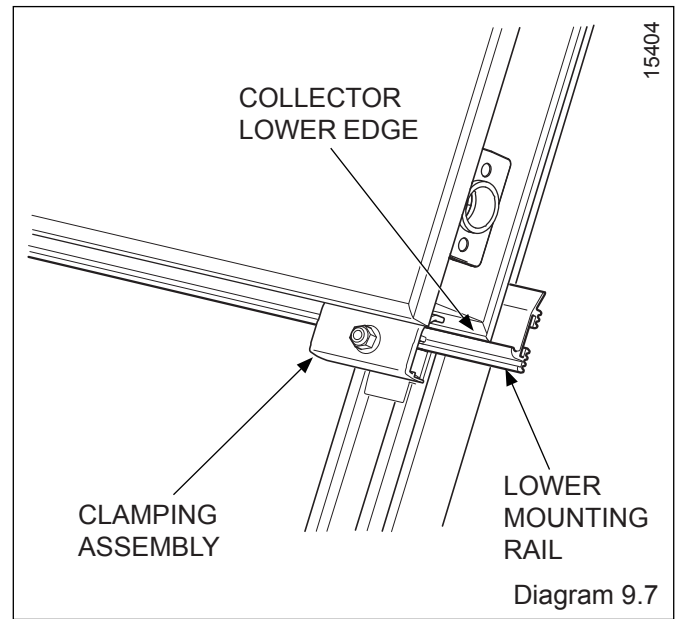



# 9 Flat Surface Installation - Horizontal Collector

Remove the plugs from the openings of the collector and insert the pipe couplings up to their stops, see diagram 9.9. Slide the retaining clips into place to secure the pipe couplings.

**NOTE:** The collector design is symmetrical and does not have a top or bottom.

Place the next collector on the lower mounting rail and slide towards the first collector.

Secure the pipe couplings to the second collector with the securing clips.

Tighten the clamping assemblies of the first collector with the socket/ combination wrench (SW13), see diagrams 9.10 and 9.11.

With regards to the hydraulic system you have chosen, insert and secure the hydraulic connections, see diagram 9.10.

Insert the collector sensor into the appropriate elbow (flow, top), see diagram 9.10. The collector sensor is packed with the Fluropro controller, part no. 0020054960.

Mount the plug with the bleed valve (vent) in the opposite top position.

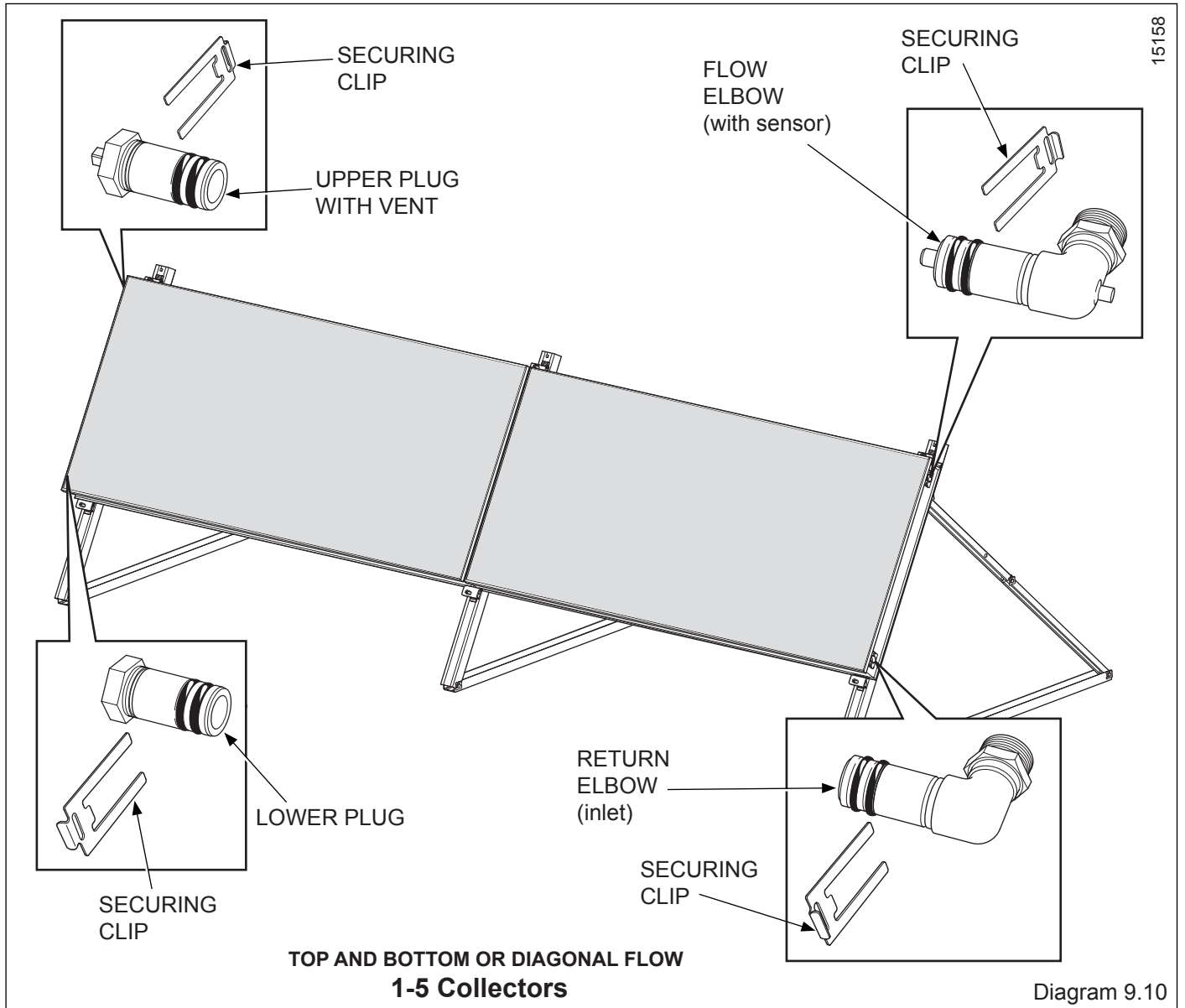
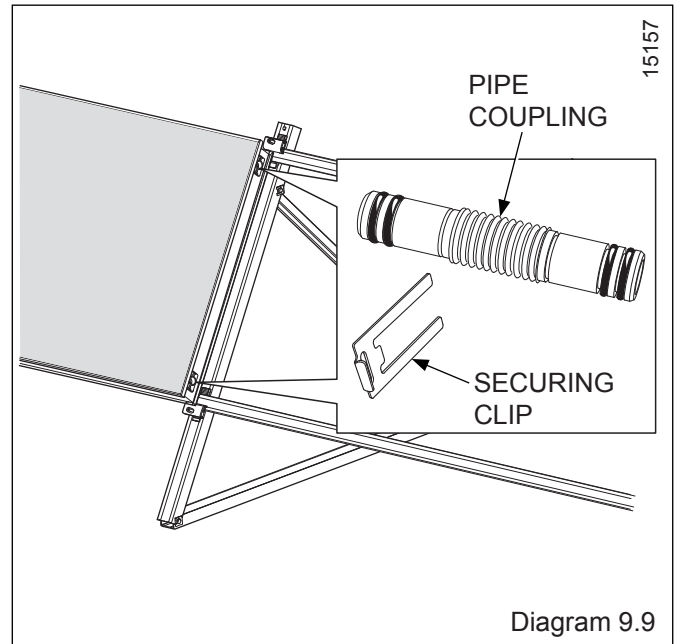

# 9 Flat Surface Installation - Horizontal Collector

Connect the collector to the system circuit.

Ensure that all of the following steps have been performed:-

- All the connections have been fixed with securing clips.
- All hydraulic connections laid properly.
- The collector sensor has been connected.
- The collector is connected to a lightning protection device.
- A pressure test.
- All insulation is intact.

**NOTE:** After initial commissioning and according to the season, high outside temperature oscillations can cause condensation in the collector, this is normal.

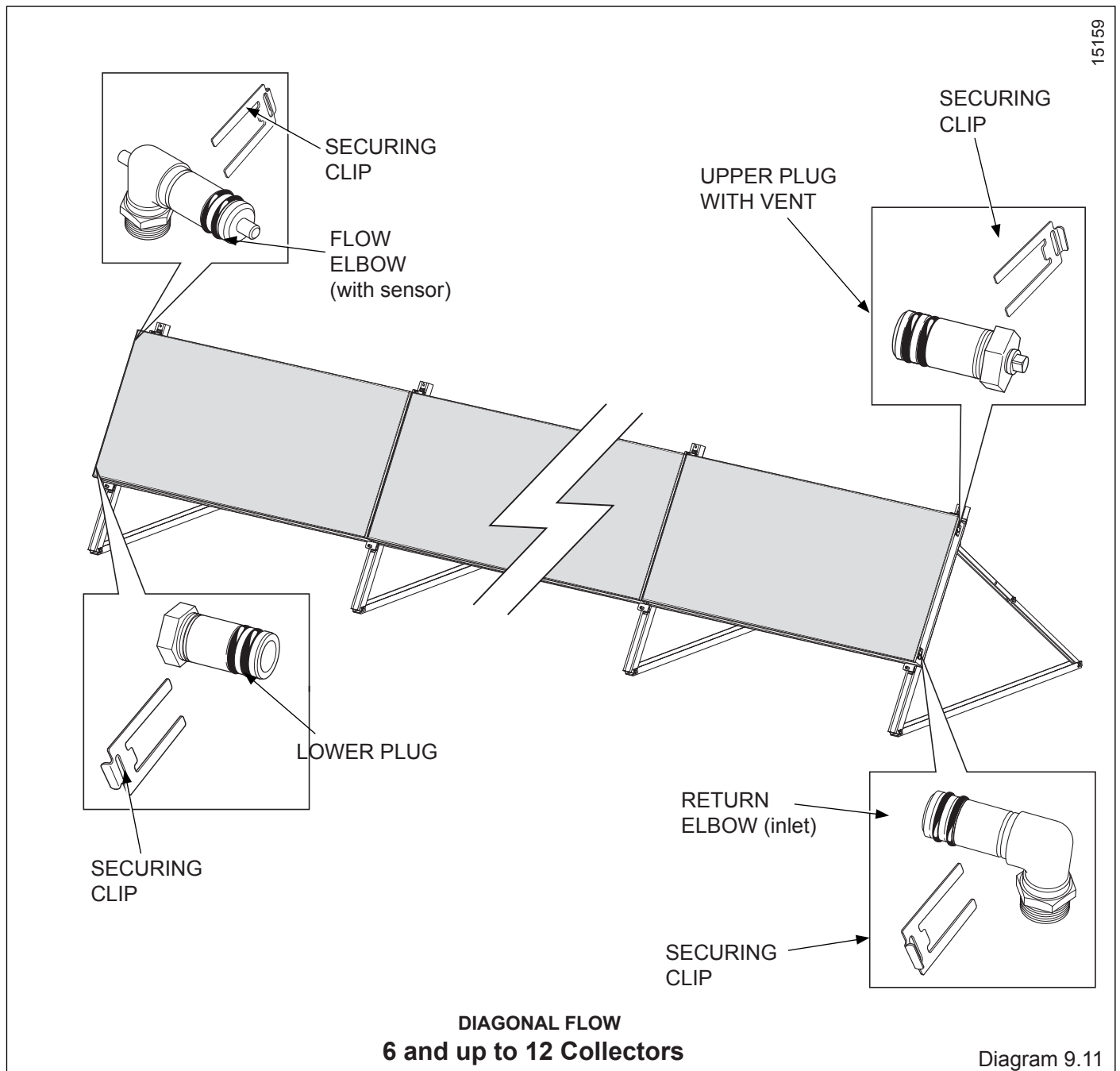



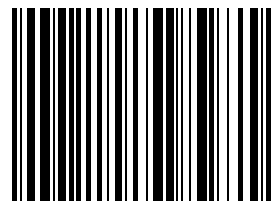

0020077782

*Because of our constant endeavour for improvement, details  
may vary slightly from those shown in these instructions.*

**Glow-worm, Nottingham Road, Belper, Derbyshire. DE56 1JT**