



# Installation & Servicing Instructions

**TO BE LEFT WITH THE USER**

**FUELSAVER 30R MkII** G.C Number 41 313 77

**FUELSAVER 40R MkII** G.C Number 41 313 78

**FUELSAVER 50R MkII** G.C Number 41 313 79

Open Flue Boilers *with Honeywell Control*

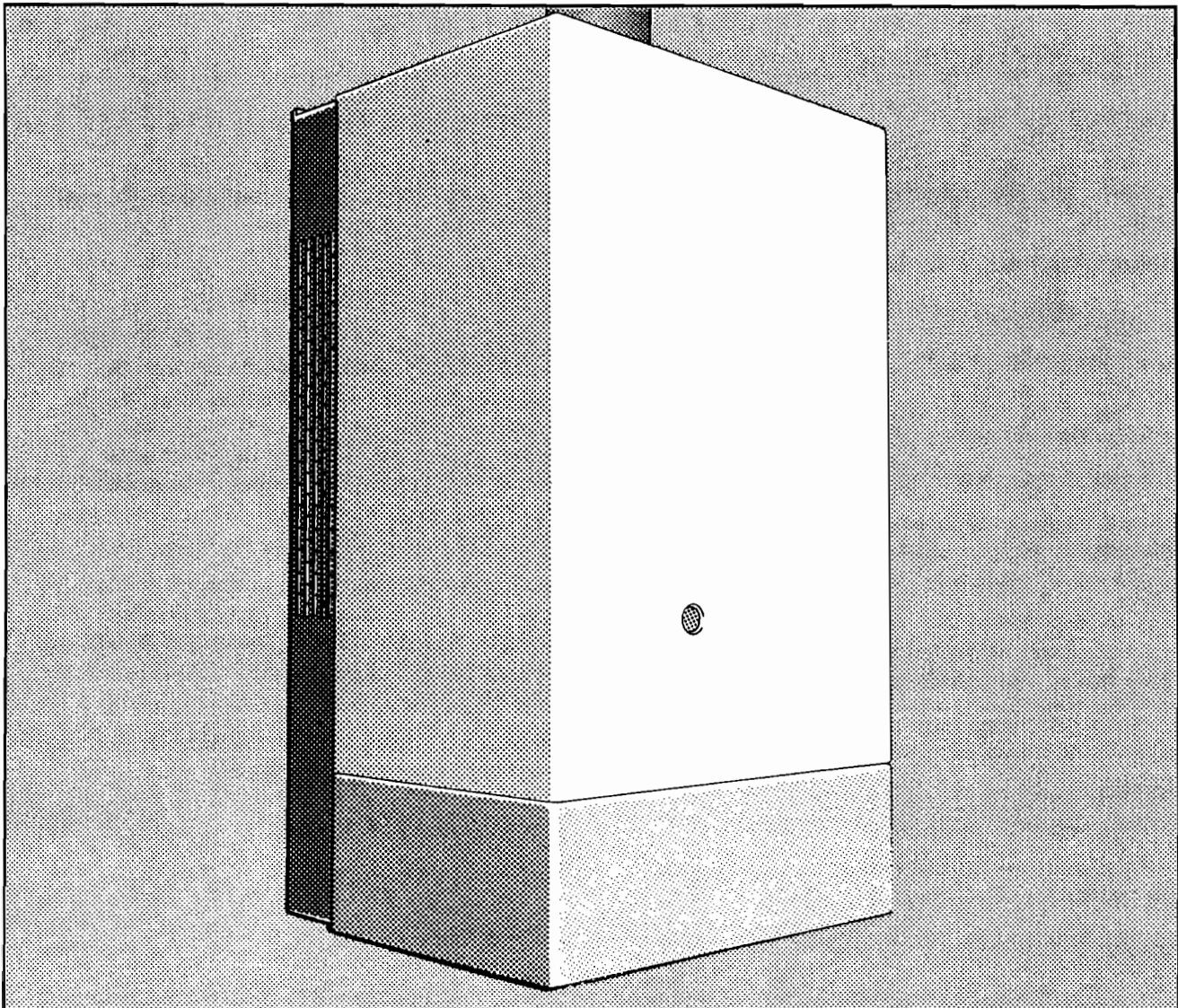

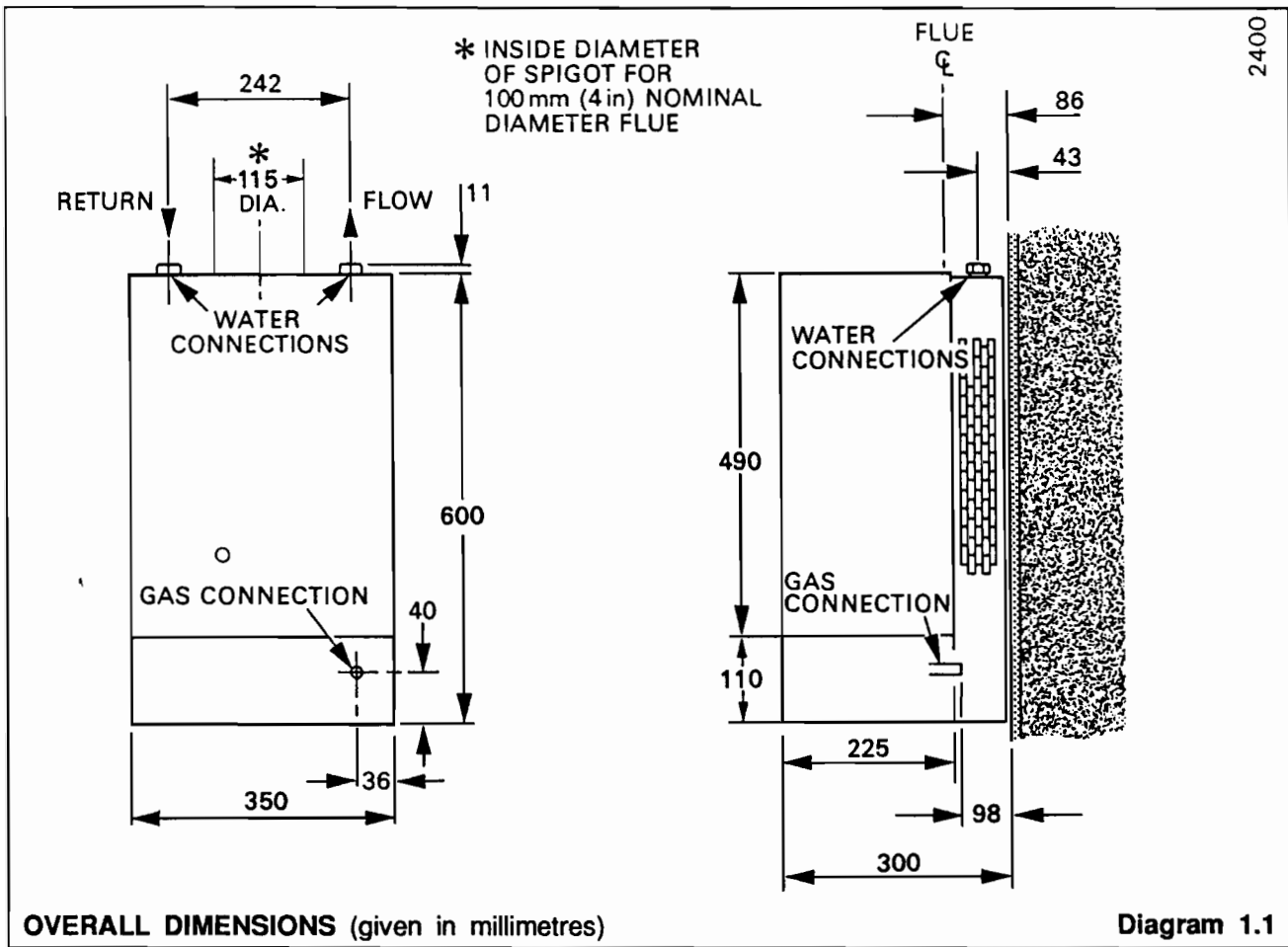

## 1 General

It is essential that the boiler is installed strictly in accordance with the instructions and information in this booklet.

**This boiler is suitable for fully pumped systems only.**

### 1.1 Important Notice

This boiler is for use on natural gas only and cannot be used on any other gas.

The boiler is delivered in one pack.

Wherever possible, all materials, appliances and components to be used shall comply with the requirements of applicable British Standards.

Where no British Standard exists, materials and equipment should be fit for their purpose and of suitable quality and workmanship.

This boiler must have fully pumped circuits, but is suitable for use with open vented or sealed water systems.

This boiler is not suitable for outdoor locations.

The boiler must not be installed in a bedroom, bed sitting room or a room containing a bath or shower.

Open flue boilers **must not** be installed in garages.

## 1.2 Sheet Metal Parts

When installing or servicing the boiler care should be taken when handling sheet metal parts to avoid any possibility of personal injury.

## 1.3 Statutory Requirements

The installation of the boiler **MUST** be carried out by a competent person in accordance with the relevant requirements of the current issue of, The Gas Safety (Installation and Use) Regulations, The Building Regulations, The Building Standards (Scotland) Regulations (applicable in Scotland), The I.E.E. Wiring Regulations, local Water Company Bylaws, The Health and Safety at Work Act.

Detailed recommendations are contained in the current issue of the following British Standard codes of practice, BS4814, BS5400 Part 1 and 2, BS5449, BS5446, BS6700, BS6798, BS6891, BS7074 Part 1 and 2.

Manufacturer's notes must not be taken in any way as overriding statutory obligations.

# I GENERAL

1.4 DATA			
MODEL	30R	40R	50R
<b>Boiler Weight</b>	18.8kg (41.4lb)	20.1kg (44.3lb)	20.7kg (45.7lb)
<b>Water Content</b>	0.451 litre (0.1gal)	0.51 litre (0.11gal)	0.61 litre (0.13gal)
<b>Injector</b>	Bray CAT 98-800	Bray CAT 98-1150	Bray CAT 98-1400

## 1.4 Data

- Gas connection - Rc 1/2 (1/2 in. BSPT)  
 Water connection - 22mm copper flow at right  
 Electrical supply - 240V~50Hz fused at 3A  
 Data label - Bottom right inner case

## 1.5 Range Rating

The boiler is range rated and may be adjusted to suit individual system requirements.

The respective Table gives the ratings and settings.

## 1.6 B.S.I. Certification

This boiler is certificated to the current issue of BS6332 Part 1, invoking the current issue of BS5258 Part 1 for performance and safety. It is, therefore, important that no alteration is made to the boiler without permission, in writing, from Hepworth Heating Ltd.

Any alteration that is not approved by Hepworth Heating Ltd., could invalidate the B.S.I. certification of the boiler, the warranty and could also infringe the current issue of the Statutory Requirements.

## 1.7 Gas Supply

The gas installation must be in accordance with the current issue of BS6891. On completion, test the gas installation for soundness and purge in accordance with the current issue of BS6891.

The supply from the meter must be of adequate size to provide a steady inlet working pressure of 20mbar (8in wg) at the boiler.

Glow-worm FUELSAVER 30R Mk II			
Range Rating	min	medium	max
Nominal Heat Input <b>kW</b>	7.33	9.17	10.99
<b>Btu/h</b>	25,000	31,300	37,500
Nominal Heat Output <b>kW</b>	5.86	7.33	8.79
<b>Btu/h</b>	20,000	25,000	30,000
Burner Setting Pressure <b>m bar</b>	7.0	10.3	14.0
<b>in.w.g</b>	2.8	4.1	5.6

Glow-worm FUELSAVER 40R Mk II			
Range Rating	min	medium	max
Nominal Heat Input <b>kW</b>	11.14	12.90	14.65
<b>Btu/h</b>	38,000	44,000	50,000
Nominal Heat Output <b>kW</b>	8.80	10.26	11.70
<b>Btu/h</b>	30,000	35,000	40,000
Burner Setting Pressure <b>m bar</b>	7.8	10.4	13.1
<b>in.w.g</b>	3.1	4.2	5.3

Glow-worm FUELSAVER 50R Mk II			
Range Rating	min	medium	max
Nominal Heat Input <b>kW</b>	14.73	16.60	18.46
<b>Btu/h</b>	50,250	56,600	63,000
Nominal Heat Output <b>kW</b>	11.72	13.19	14.65
<b>Btu/h</b>	40,000	45,000	50,000
Burner Setting Pressure <b>m bar</b>	8.8	10.7	13.2
<b>in.w.g</b>	3.5	4.3	5.3

### 1.8 Electrical Supply

**Warning.** This boiler must be earthed.

All system components shall be of the approved type and be wired and connected in accordance with requirements the current issue of The I.E.E. Wiring Regulations and any applicable local regulations.

Connection of the boiler and system controls to the mains supply must be through a common isolator and must be fused 3A maximum. The method of connection should be, preferably, by a fused double pole isolating switch, provided it has a minimum contact separation of 3mm on both poles. This switch should be readily accessible and preferably adjacent to the appliance. It should supply the appliance only and be easily identifiable.

socket outlet and 3A fused 3 pin plug both to the current issue of BS1363 may be used

Wiring to the boiler must be PVC insulated cable at least 0.75mm<sup>2</sup> (24/0.20mm) to the current issue of BS6500 Table 16.

### 1.9 Draining Tap

A draining tap must be provided at the lowest points of the system which will allow the entire system, boiler and domestic hot water cylinder to be drained.

Draining taps shall be to the current issue of BS2879.

### 1.10 Safety Valve

Where as safety valve is fitted it should be on the flow pipe, as near to the boiler as possible, there must not be any intervening valve or cock.

The discharge must be clear of any electrical fittings.

If fitted to a sealed water system note the special requirements.

### 1.11 Clearances

The boiler position should be such that the clearances shown in diagram 1.2 are achieved.

Additional clearances may be required for installation.

If fixtures are positioned next to the boiler they should be made removable for access to pipework.

Sufficient clearance must be left in front of the boiler for servicing.

The casing side grilles must be kept clear at all times.

The boiler must be mounted on a flat wall which is sufficiently robust to take its weight.

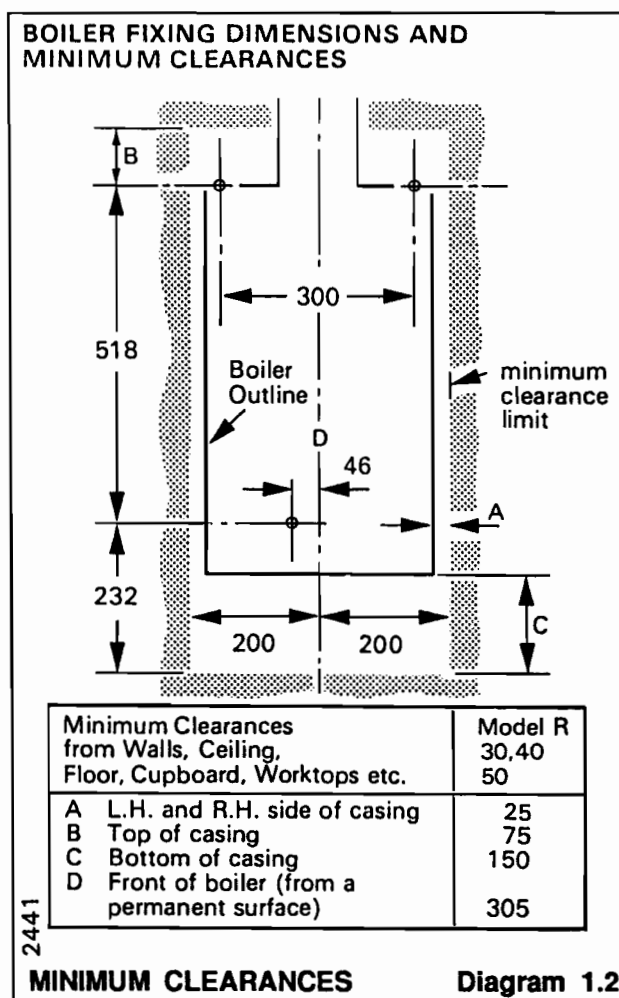

### 1.12 Timber Frame Buildings

If the boiler is to be installed in a timber frame building it should be fitted in accordance with the British Gas Publication "Guide to Gas Installations in Timber Framed Housing", reference DM2. If in doubt seek advice from the local gas undertaking or Hepworth Heating Ltd.

The integral draught diverter on the boiler makes the combustion performance independent of the conditions in the secondary flue, but in common with other fuels an efficient flue is necessary to ensure a trouble free installation.

The flue outlet on the boiler is designed to take flue pipes to BS567. If a flue pipe to BS715 is to be used an adaptor must be fitted to the boiler flue socket.

The flue must be in accordance with the current issue of BS5440 Part 1.

Give maximum possible vertical rise from the boiler, at least a minimum of 600mm, before any offset or bend. The use of 90° bends is not recommended.

An existing flue must be lined and terminate, at least above ridge height, with an approved terminal.

A chimney previously used for solid fuel must be swept and any damper or register plate removed.

**2.1 Boilers in a Compartment**

Where the installation of the boiler will be in an unusual location, special procedures are necessary, the current issue of BS6798 gives detailed guidance on this aspect.

A compartment used to enclose the boiler must be designed and constructed specifically for this purpose. An existing cupboard or compartment modified for the purpose may be used. Details of essential features of cupboard or compartment design are given in the current issue of BS6798.

The doorway opening should be of sufficient size to allow for easy removal of the boiler.

Where the boiler is fitted in a cupboard or compartment, permanent high and low level ventilation must be provided.

The minimum ventilation areas required are given in Table "A".

**2.2 Boiler Installed in a Room or Space**

A purpose designed ventilation opening must be provided on an outside wall of the premises, refer to the current issue of BS5440 Part 2 for further information.

The opening may be either, directly into the room or space containing the boiler or, into an adjacent room or space which has an internal permanent air vent of the same size as the room containing the boiler.

DO NOT ventilate through a bedroom, bed sitting room, garage or a room containing a bath or shower.

Air vents through a cavity wall must be ducted.

<b>TABLE "A" COMPARTMENT AIR VENTS</b>		
<b>FUELSAVER 30R Mk II</b>		
Ventilation Requirements	High Level Vent Area	Low Level Vent Area
Air from room or internal space	99cm <sup>2</sup>	198cm <sup>2</sup>
Air direct from outside	50cm <sup>2</sup>	99cm <sup>2</sup>
<b>FUELSAVER 40R Mk II</b>		
Ventilation Requirements	High Level Vent Area	Low Level Vent Area
Air from room or internal space	132cm <sup>2</sup>	264cm <sup>2</sup>
Air direct from outside	66cm <sup>2</sup>	132cm <sup>2</sup>
<b>FUELSAVER 50R Mk II</b>		
Ventilation Requirements	High Level Vent Area	Low Level Vent Area
Air from room or internal space	167cm <sup>2</sup>	333cm <sup>2</sup>
Air direct from outside	83cm <sup>2</sup>	167cm <sup>2</sup>

<b>TABLE "B" ROOM/SPACE AIR VENTS</b>			
<b>FUELSAVER R Mk II</b>			
MODEL	30R	40R	50R
Effective area of vent	18cm <sup>2</sup>	35cm <sup>2</sup>	152cm <sup>2</sup>

When the boiler is installed in a space already containing a fuel burning appliance account must be taken of the TOTAL air requirement.

**2.3 Extract Fans**

If an extract fan is fitted in the premises there is a possibility that if adequate air openings are not provided spillage of products from the boiler may occur.

When openings are fitted in accordance with the recommendations of the current issue of BS5440 Part 1 and this section, extract fans should not cause spillage, but where such an installation is found spillage tests as the current issue of BS5440 Part 1 must be carried out.

The necessary action should then be taken.



**NOTES:**

The pump, valved, with integral valves, if possible, should be fitted in the flow pipework from the boiler, to produce a temperature difference across the boiler of 11°C (20°F).

See diagram 3.1 for pressure loss across the boiler.

High resistance microbore systems may require a higher duty pump.

**BYPASS**

A bypass must be fitted, see diagram 3.2.

The flow through the boiler must not be allowed to fall below:

- 30R - 7.8L/min (1.7gal/min)
- 40R - 10.5L/min (2.3gal/min)
- 50R - 13.2L/min (2.9gal/min)

whilst the burner is alight.

**3.1 Open (Vented) Water System**

For an open (vented) water system the boiler must be supplied from an unrestricted water supply taken from a cold feed and expansion cistern (minimum 22 litre (5gal) capacity situated at a maximum height of 27.5 metre (90ft) above the boiler.

The cold feed supply must be 15mm minimum size.

It is important that the relative position of the pump, cold feed and open vent are as shown in diagram 3.2.

**3.2 Domestic Hot Water Cylinder**

The domestic hot water cylinder must be of the double feed, fully indirect type. Single feed, self priming cylinders are not recommended.

**3.3 Inhibitor**

Attention is drawn to the current issue of BS5449 on the use of inhibitors in central heating systems.

If an inhibitor is to be used, contact a manufacturer for their recommendations for the best product to use.

Where installing a boiler in an existing system, whether or not using an inhibitor, take special care to drain the entire system, including the radiators, then thoroughly flushing out before fitting the boiler and adding the inhibitor.

**3.4 Sealed water Systems**

The installation should comply with the appropriate requirements of the current issue of BS4814, BS5449, BS6798 and BS7074 Part 1 and 2. See diagram 3.3 for a diagrammatic layout.

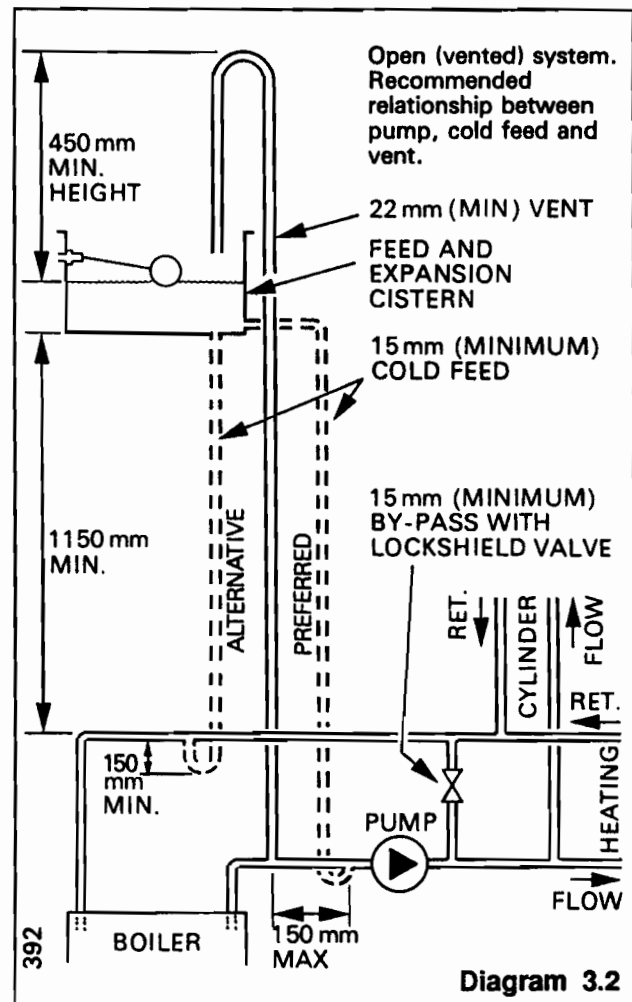
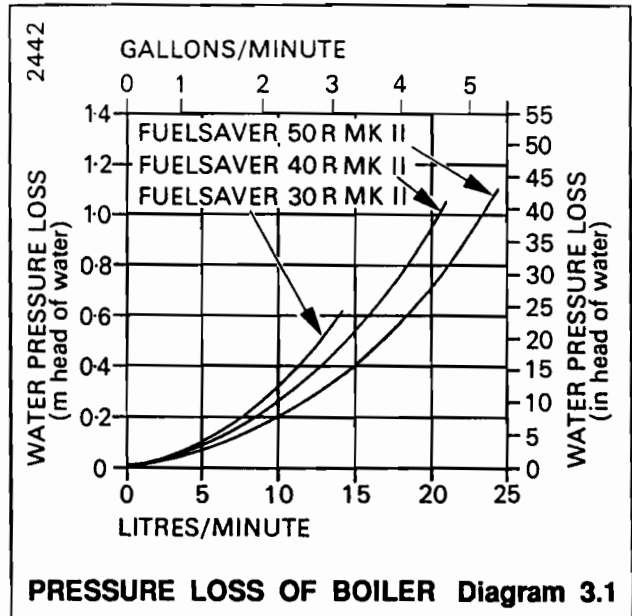

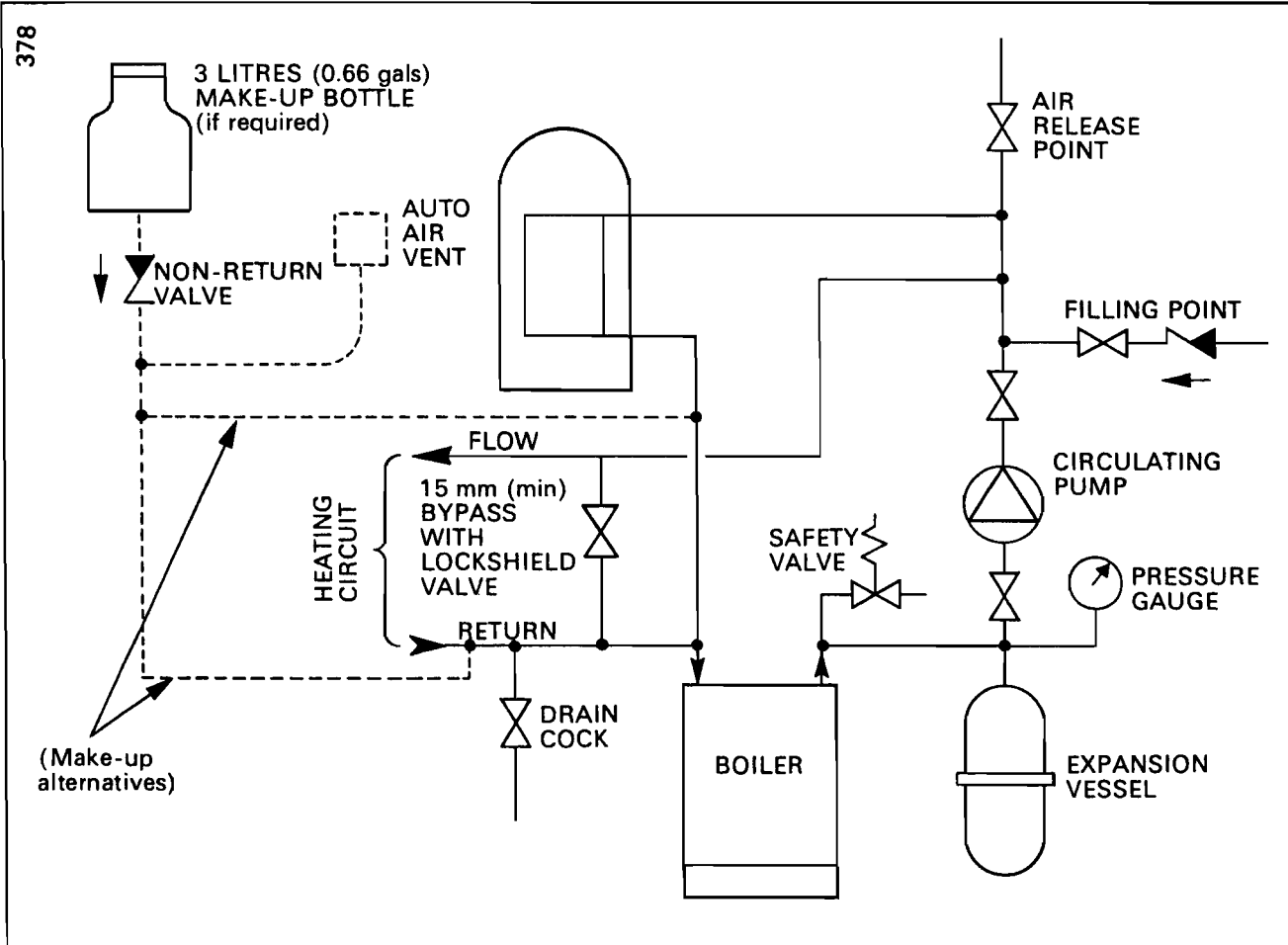

SEALED WATER SYSTEM DIAGRAMMATIC LAYOUT

Diagram 3.3

**3.5 Safety Valve**

A safety valve must be fitted to a sealed water system.

It shall be preset, nonadjustable with a lift pressure of 3bar, incorporating seating of a resilient material, a test device and a connection for drain.

The drain from the safety valve must be routed clear of any electrical fittings and positioned so that any discharge can be seen.

**3.6 Expansion Vessel**

A diaphragm type expansion vessel, conforming to the current issue of BS4814 (see also the current issue of BS7074 Part 1 and 2) must be connected at a point close to the inlet side of the circulating pump, see diagram 3.3, unless laid down differently by the manufacturer.

The expansion vessel volume depends on the total water system volume and the initial system design pressure. For any system an accurate calculation of vessel volume size is given in the current issue of BS7074 Part 1.

Guidance is also given in the current issue of BS5449.

EXPANSION VESSEL SYSTEM		
EXPANSION VESSEL PRESSURE (BAR)	0.5	
INITIAL SYSTEM PRESSURE (BAR)	0.5	1.0
EXPANSION VESSEL VOLUME (LITRES)	A x 0.075	A x 0.126
EXPANSION VESSEL PRESSURE (BAR)	1.0	
INITIAL SYSTEM PRESSURE (BAR)	1.0	1.5
EXPANSION VESSEL VOLUME (LITRES)	A x 0.098	A x 0.171
A - SYSTEM VOLUME	Diagram 3.4	

1025

The charge pressure must not be less than the static head of the system, that is, the height of the highest point of the system above the expansion vessel.

The water capacity of the boiler is given in Section 1.

### 3.7 Pressure Gauge

A pressure gauge with a set pointer and covering at least the range of 0 to 4 bar (0 to 60lb/in<sup>2</sup>) shall be permanently fitted to the system in a position where it can be seen when filling the system.

### 3.8 Domestic Hot Water Cylinder

SINGLE FEED INDIRECT CYLINDERS ARE NOT SUITABLE.

The domestic hot water cylinder must be of the indirect coil type. It must be suitable for working at a gauge pressure of 0.35bar above the safety valve setting.

### 3.9 Water Make-up

Provision should be made for the replacing the water loss from the system using a make up bottle or filling loop mounted in a position higher than the top point of the system, connected through a non-return valve to the return side of either the heating circuit of the domestic hot water cylinder.

Alternatively, provision for make up can be made by using a filling loop.

### 3.10 Filling a Sealed Water System

Provision for filling the system at low level must be made. Three methods are shown in diagram 3.5. There must be no permanent connection to the mains water supply, even through a non-return valve.

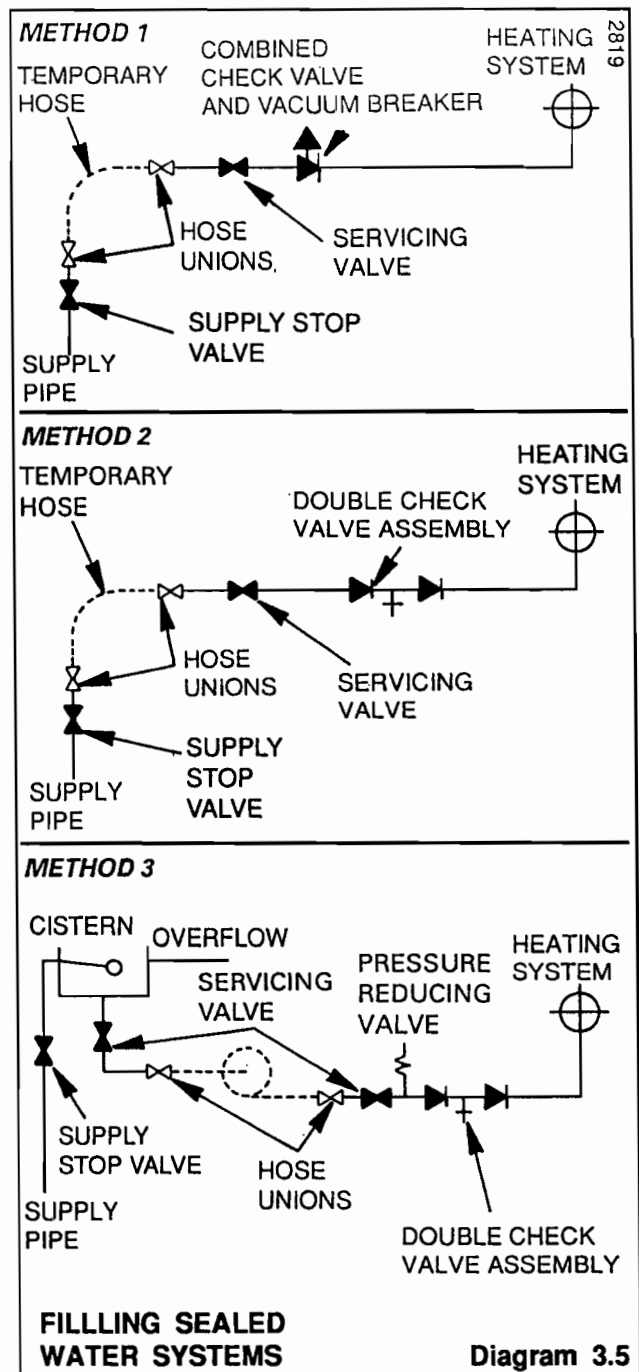



### 4.1 Appliance Preparation

Remove the boiler from the carton and lay it on its back.

The side grilles are packed in the bottom of the carton.

Remove the controls cover by pulling it forward and off, see diagram 4.1.

Remove the outer case by undoing the screws at the bottom and unhooking at the top, see diagram 4.1.

Remove the two screws and attach the side grilles by hooking over the top of the side panel and secure, see diagram 4.1.

### 4.2 Appliance Fitting

Refer to diagram 1.2 for fixing screw positions and minimum clearances.

Mark position of the three fixing screws.

Drill and plug the holes, suitable for No10x2in woodscrews.

Fit the screws, leave about 6mm proud.

Hook the boiler on to the lower screw and keyhole slots at the top, tighten all screws.

Connect the system pipework to the boiler.

Fix the flue to the flue hood in accordance with normal practice.

### 4.3 Gas and Water Connection

Connect the gas supply to the Rc<sup>1</sup>/<sub>2</sub>in gas cock.

The whole of the gas installation, including the meter, should be inspected, tested for soundness and purged in accordance with the current issue of BS6891.

Connect the water to the boiler, using nuts and olives supplied to BS2871 copper tube.

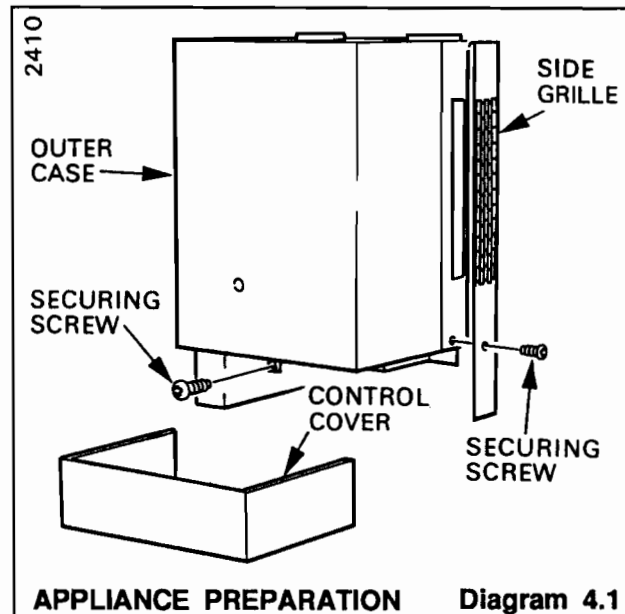

### 4.4 Casing

Refit the outer casing by hooking on at the top and securing with the screws previously removed, see diagram 4.1.

Ensure that the side grilles are kept clear.

### 5.1 Electrical Connection

WARNING, the boiler must be earthed and have a permanent mains supply.

To remove the control box release the two screws at the front, see diagram 5.1, lower the box until it is clear then push backward to disengage the hinge at the rear, see diagram 5.1. Take care not to damage the thermostat and capillaries.

Thread the mains lead through the clamp in the rear of the control box cover and connect to the terminal strip.

When making the connections, the earth lead should be of a greater length than the others so that it would be the last to become disconnected.

### 5.2, Pump and External Controls Connections

The pump must be wired into the boiler control box as shown in diagram 5.2.

Any external controls must only be wired to interrupt the Red link between terminals 9 and SL.

Take the strain relief grommets from the loose items pack. Place around the external controls and pump connection cables respectively.

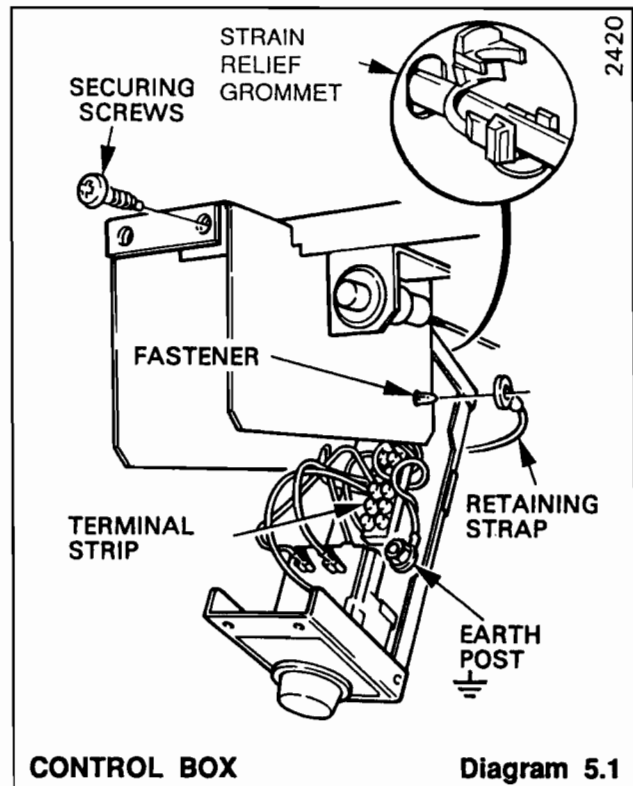

CONTROL BOX Diagram 5.1

Squeeze the sides of the grommets when pushing them into the obround holes in the rear of the control box, see diagram 5.1. Ensure the supply cable and all external cables are secured.

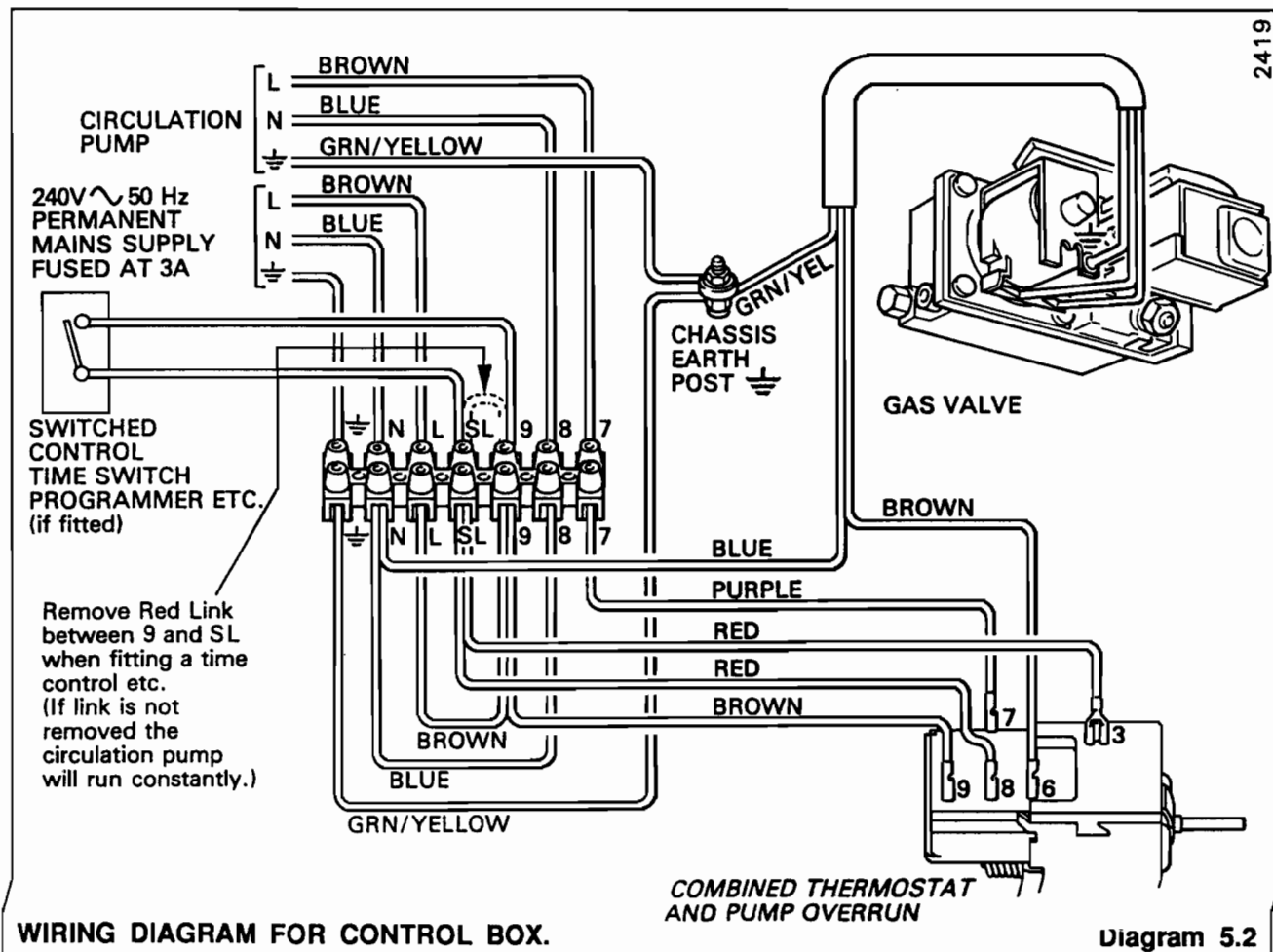

WIRING DIAGRAM FOR CONTROL BOX. Diagram 5.2

### 5.3 Testing

In the event of an electrical fault after installation preliminary system checks must be carried out as described in a Multimeter test book.

The installer is requested to advise and give guidance to the user of the controls scheme used with the boiler.

## 6 COMMISSIONING

### 6.1 All Systems

Ensure that the system has been thoroughly flushed out with cold water without the pump in place.

Refit the pump, fill the system with water, ensuring that all the air properly vented from the system and pump.

Before operating the boiler make sure that all external controls are calling for heat.

### 6.2 Sealed Water Systems Only

Flush the whole system with cold water without the pump in place. Refit the pump and fill until the pressure gauge registers 1.5bar (21.5lbf/in<sup>2</sup>). Clear any airlocks and check for water soundness.

Check the operation of the safety valve, by allowing the water pressure to rise until the valve opens. The valve should open within +/-0.3bar (+/-4.3lbf/in<sup>2</sup>) of the 3bar preset pressure. Where this is not possible conduct a manual check and test.

Release cold water to initial system design pressure.

The set pointer on the pressure gauge should be set to coincide with the indicating pointer.

### 6.3 Initial Lighting and Testing - All Systems

Refit the outer case, see diagram 4.1.

Identify the controls by reference to diagram 6.1.

Turn the boiler thermostat control "A" to "O"

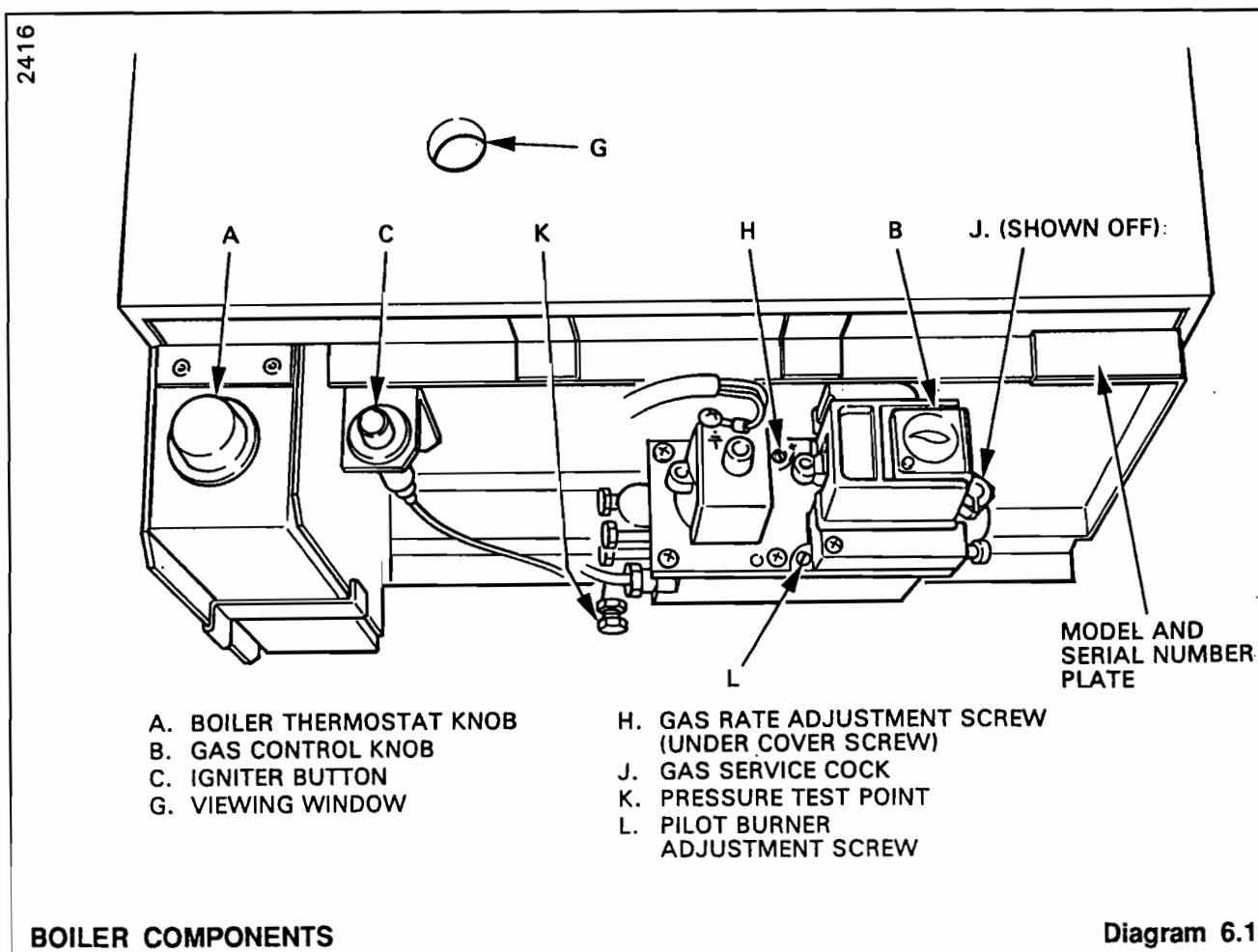

Remove the pressure test point screw "K" and fit a suitable pressure gauge.

Turn the electrical supply on and check that the pump is working.

Open all windows and put out any naked lights, pipes, cigarettes and the like.

Turn on the main gas supply and purge in accordance with the current issue of BS6891.

Turn the boiler gas service cock "J" to On.

Depress control button "B", keep pressed in and at the same time operate the piezo button "C" until the pilot burner lights. After the pilot burner lights keep the button "B" depressed for about 15 seconds. If the pilot burner fails to light or stay alight a safety device prevents immediate relighting. Do not attempt to relight until the safety device has reset. Check the length of the pilot flame, it should envelop the thermocouple tip as shown in diagram 7.7. The pilot rate can be adjusted by turning screw "H", having first removed the gas valve cover by releasing the screws, see diagram 6.1. Test pilot supply connections for soundness with a suitable leak detection fluid.

Fit the outer case, secure with the screws previously removed.

Make sure that the pilot is alight and stable, view through window "G".

Set the boiler thermostat knob "A" between "MIN" and "MAX" ("MAX" is about 82°C (180°F) and check that the burner lights smoothly. Check all gas connections for soundness with a suitable leak detection fluid.

To set the burner pressure operate the boiler for 10 minutes, remove the gas valve cover, if not already removed, adjust the gas pressure by screw "H" until the required pressure is obtained, see the relevant Table 1 for setting pressures.

Align the self adhesive arrow, from the loose items pack, in the appropriate space beneath "MIN" and "MAX" column on the data label.

Should any doubt exist about the gas rate this should be checked at the meter, using a stop watch to time at least one cubic foot of gas consumption.

Replace the gas valve cover.

Remove the pressure gauge and refit the screw, ensure that a gas tight seal is made.

### 6.4 Testing

Check the operation of the flame failure device on the boiler to ensure that the gas valve shuts down within 60 seconds.

### 6.5 Flushing

Allow the system to reach maximum working temperature and examine for water leaks.

The boiler should then be turned off and the system drained as rapidly as possible whilst still hot.

Refill the system and vent and check for water soundness as before.

### Adjustment - All Systems

When commissioning the system the boiler should first be fired on full service, that is, central heating and domestic hot water. The system should then be balanced, adjusting the pump and lockshield valve as necessary. Having achieved a satisfactory condition operate the boiler with the bypass fully closed on minimum load, normally this will be central heating with one radiator, in the main living area working. The valve should then be gradually opened to achieve a flow rate of 7.8l/min (1.7gal/min).

**Under no circumstances should this valve be left in the fully closed position.**

Operate the boiler again on full service and check the balancing, making further adjustments as necessary.

If thermostatic radiator valves are fitted care must be taken to ensure adequate flow through the boiler when they close.

Test the boiler for spillage of the flue products at the draught diverter as detailed in the current issue of BS5440 Part 1. See also Section 2.3.

### 6.7 Adjustment - Sealed Water Systems

Sealed water systems should be adjusted to the initial design pressure and the set pointer repositioned.

### 6.8 Instruct the User in the Correct Operation of the Boiler

Hand the User Instructions to the user for their retention and use.

Instruct and demonstrate the safe and efficient operation of the boiler, heating system and domestic hot water system.

Advise the user, that to ensure the continued efficient and safe operation of the boiler it is recommended that it is checked and serviced at regular intervals. The frequency of servicing will depend upon the particular installation and usage, but in general once a year, preferably at the end of the heating season should be enough.

It is the Law that servicing is carried out by a competent person.

Leave these instructions with the user for use during future service calls.

**7 Servicing and Replacement of Parts**

For the continued efficient and safe operation of the boiler it is recommended that it is checked and serviced at regular intervals. The frequency will depend upon the particular installation and usage, but in general once a year, preferably at the end of the heating season should be enough.

It is the Law that any servicing must be carried out by a competent person.

Servicing and Replacement of parts must be carried out by a competent person.

Before commencing a service or replacing parts isolate the gas and electrical supplies.

Unless stated otherwise all parts are replaced in the reverse order to removal.

**7.1 Heating Body - Service**

Remove the controls cover by pulling it forward and off.

Remove the outer casing by releasing the screw at the bottom and unhooking at the top.

Remove the inner casing by releasing the wing nuts at the top and the screws at the bottom, see diagram 7.1.

Remove the combustion chamber front by unscrewing the wing nut at the bottom front and the four screws, see diagram 7.2.

Disconnect the ignition lead from the electrode and unscrew thermocouple nut to release, see diagram 7.3.

Support the main burner and release pilot tubing nut at the base of burner, release pilot tube. The pilot injector can now be removed by unscrewing, see diagram 7.3.

Disengage the main burner from the main injector. Raise the burner up through the combustion chamber to remove. Take care not to damage the side insulation.

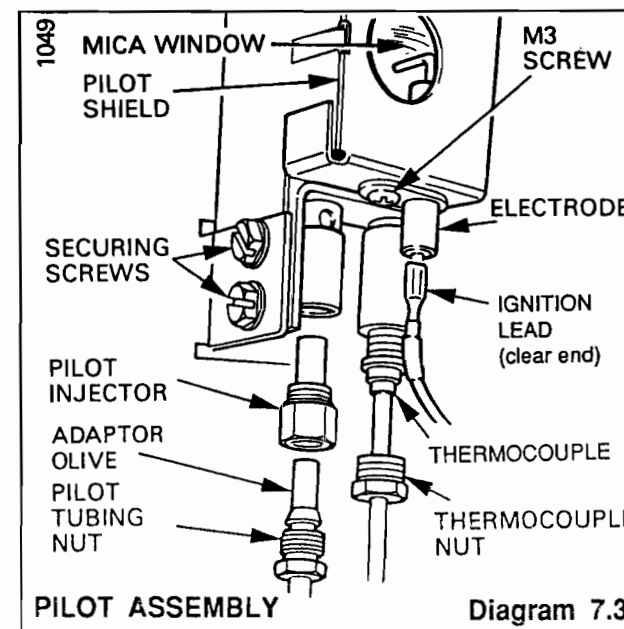
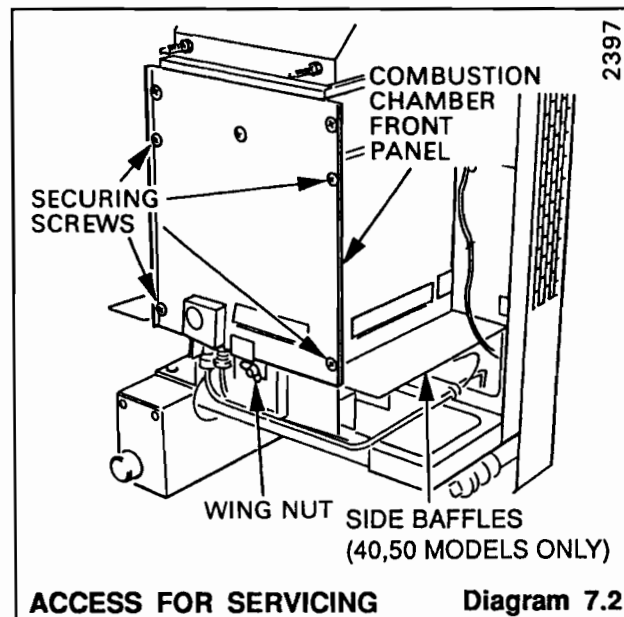
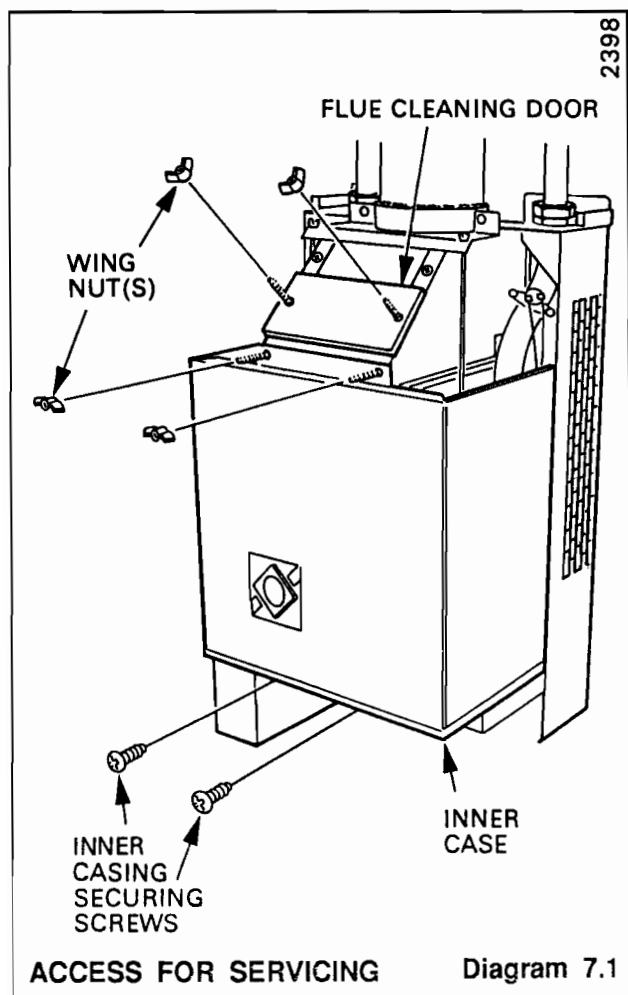

Place the burner to one side.

Cover the combustion chamber and injector with a sheet of paper.

Remove the flue cleaning door, see diagram 7.1.

Remove the screws securing the draught diverter baffle and lower out as shown in diagram 7.4.

Brush away any deposits from the heat exchanger etc.

Remove the paper together with any debris.

When replacing parts ensure that the draught diverter is refitted correctly.

### 7.2 Main Burner - Service

Generally follow the instructions given in Section 7.1.

With the main burner removed brush or vacuum any deposits away, ensure that the flame ports are clear.

Do not use a brush with metallic bristles.

Note. Alternative type of burner are fitted to some models. Remove lint arrester from main burner and clean it thoroughly by brushing or vacuuming, see diagram 7.5 for Bray burner and diagram 7.6 for Furigas burner.

### 7.3 Main Injector

Generally follow the instructions given in Section 7.1.

With the main burner removed the injector can be unscrewed and replaced as necessary, using a new sealing washer.

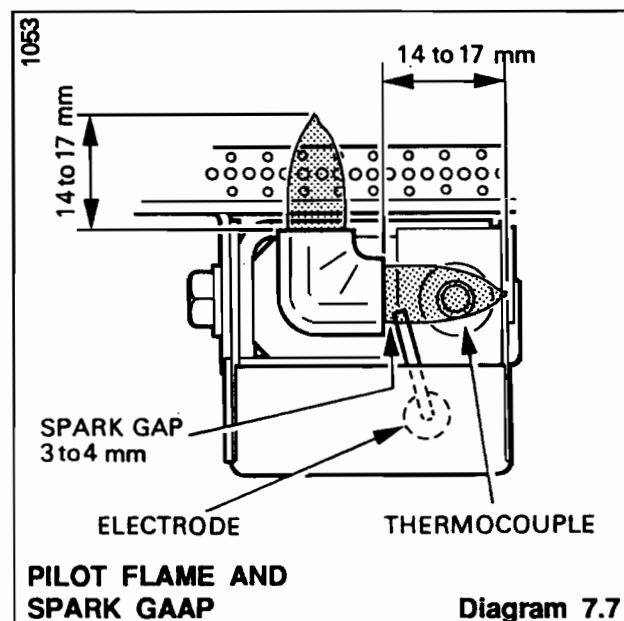
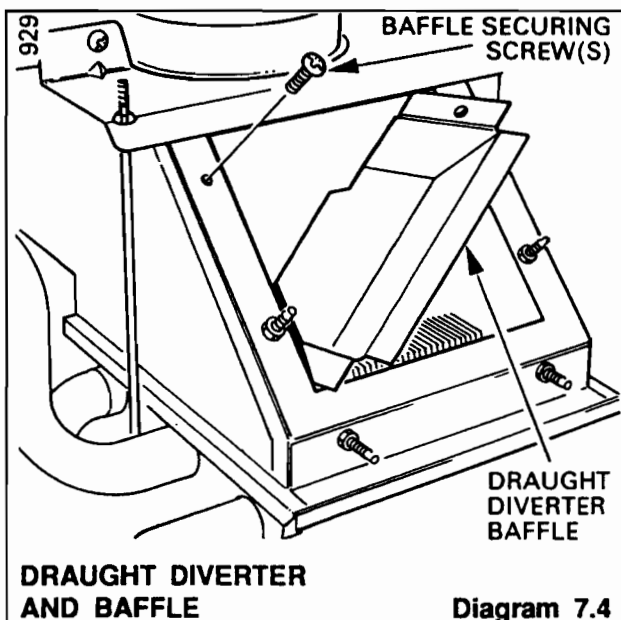
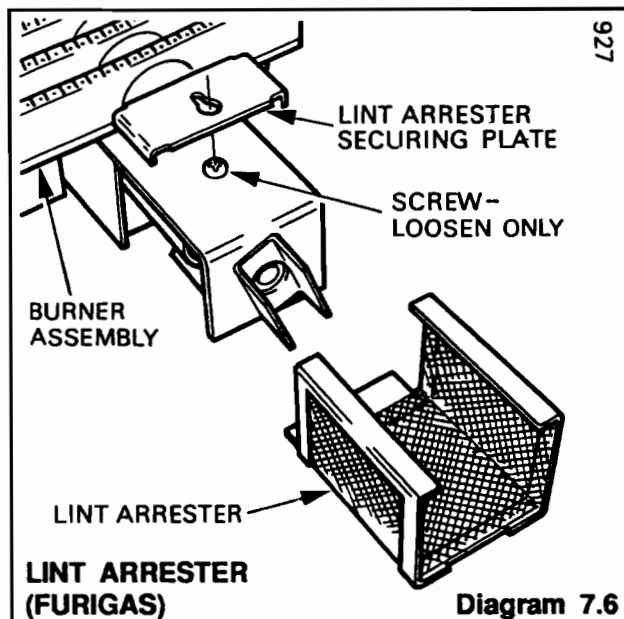
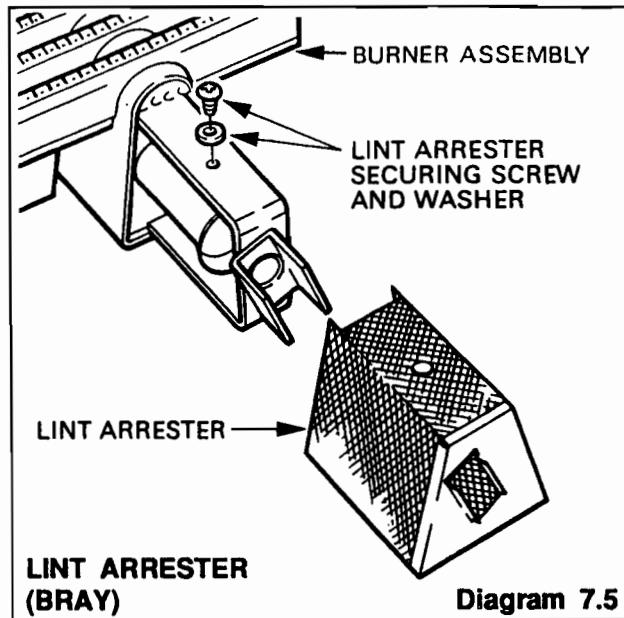



If cleaning do not use a wire or sharp instrument on the hole.

When replacing the main burner ensure that it is pushed fully home onto the injector and that the guides are engaged on the injector manifold.

### 7.4 Pilot Burner and Injector - Service

Generally follow the instructions given in Section 7.1.

With the main case, inner case and controls cover etc., removed as above, pull off ignition lead from the electrode.

Unscrew the tubing nut at the base of the pilot burner, releasing the pilot pipe. Remove the pilot injector by unscrewing from the pilot burner.

Unscrew the thermocouple nut to release the thermocouple from the pilot burner.

Support the main burner and remove the two screws and washers securing the pilot burner and shield to burner.

Remove the complete assembly.

Lift the pilot burner off.

Take care not to damage the electrode.

When replacing ensure the spark gap is as shown in diagram 7.7.

Check the pilot burner flame lengths are as shown in diagram 7.7.

### 7.5 Thermocouple

Generally follow the instructions given in Section 7.1.

Unscrew the thermocouple nut to release from the pilot burner, see diagram 7.3.

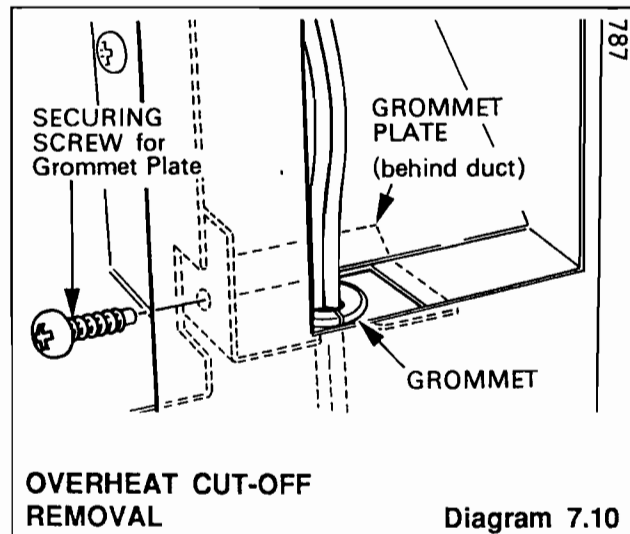
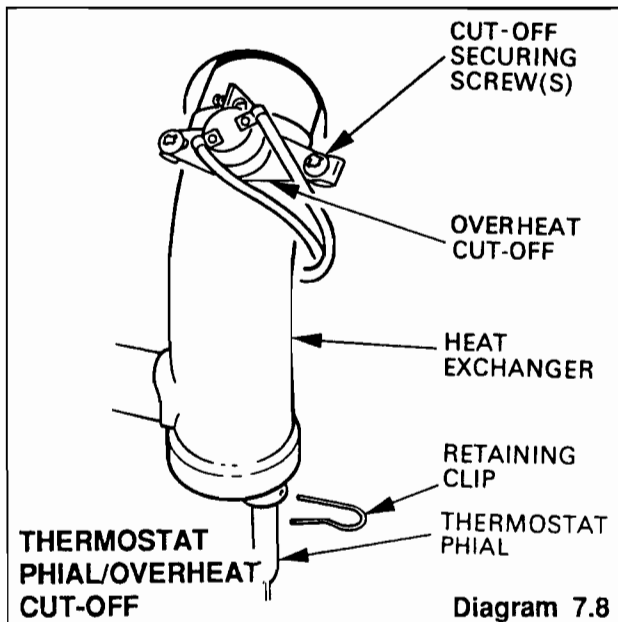
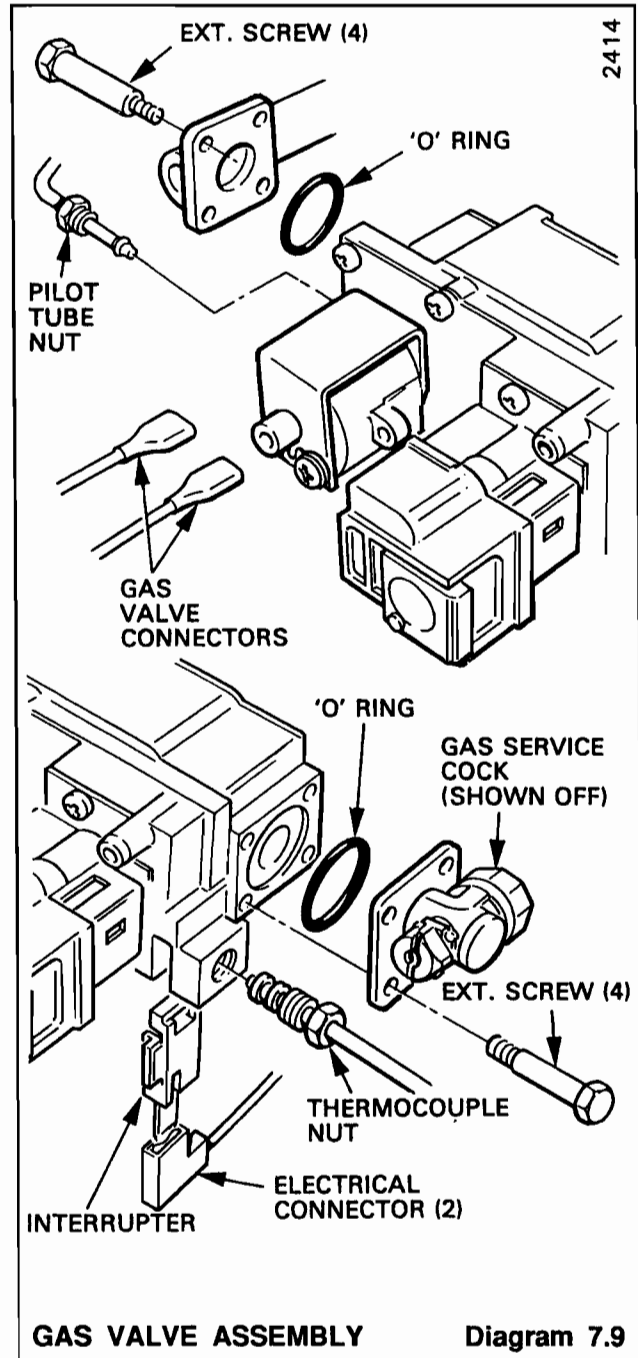

Disconnect the thermocouple from the gas valve, see diagram 7.9.

Use the old thermocouple as a pattern when fitting the new one. Do not tighten more than a quarter turn beyond finger tight at the gas valve.

Check the electrode spark gap, see diagram 7.7.

### **7.6 Electrode**

Generally follow the instructions given in Section 7.1.

Unscrew the electrode from the pilot shield.

When refitting check that the spark gap is as diagram 7.7.

### **7.7 Over Heat Cutoff**

Generally follow the instructions given in Section 7.1.

Remove the screws securing the over heat cutoff to the clamp, see diagram 7.8.

Release the cutoff connectors at the gas valve, see diagram 7.9.

Remove the screw retaining the grommet plate to the rear panel to release plate, see diagram 7.10.

Carefully remove, one at a time, the cables of the cutoff through the grommet.

When reassembling use a little of the heat sink compound, supplied, on the face of the cutoff to ensure a good contact with the pipe also ensure it is correctly located.

### **7.8 Gas Valve**

Generally follow the instructions given in Section 7.1.

Remove screw to release gas valve cover.

Disconnect all leads and pipes at valve.

Undo the four screws each side of the valve to release the service cock and burner supply tube, take care not to damage the "O" rings.

Remake all connections.

Do not tighten the thermocouple nut more than a quarter turn beyond finger tight.

It will be necessary to purge pipework and gas valve before relighting, refer to Commissioning.

### **7.9 Electrical Control Box**

Remove controls cover and outer casing as above.

Remove retaining clip from boiler thermostat phial pocket and withdraw the phial, see diagram 7.8.

Remove the control box by undoing the two fixing screws at the front and lower the front of the box until it is clear of the cover. Push the box toward the rear of the boiler to disengage the hinge and lower, see diagram 5.1.

Withdraw the thermostat capillary through the bottom of the air duct.

Disconnect cables (a) mains, L, N and E (b) pump at terminal 8, 7 and earth stud, (c) cables at gas valve, (d) disconnect any remote controls at terminals 9 and SL.

When replacing refer to diagram 5.2 for electrical connections. Smear the thermostat phial with heat sink compound and ensure it is secured with the retainer, in the pocket.

### **7.10 Piezo Unit**

Gain access generally as Section 7.1.

Disconnect ignition lead and remove backing nut from piezo unit.

### **7.11 Ignition Lead**

Gain access generally as Section 7.1.

Disconnect the ignition lead at both ends.

When replacing the clear end fits to the electrode.

### **7.12 Thermostat**

Gain access generally as Section 7.1.

Remove and support the control box.

Remove the control knob and electrical connections from the thermostat body.

Pull off the connectors from the thermostat terminals. Remove the two screws securing the thermostat to the control box. The thermostat can now be removed.

When replacing smear the thermostat phial with a little heat sink compound, supplied, before fitting into the pocket.

Fault and Cause	Remedy
<b>8.1 Pilot Goes Out after a Period of Remaining Alight</b>	
Front cover not correctly fitted.	Fit parts correctly.
Flue parts not fitted or sealed properly.	Seal cavity or fit flue parts correctly as described in installation instructions.
Electrical supply failure causing over heat cutoff to operate.	Relight pilot.
Overheat cut-off operating.	Refer to Section 8.3.
Pump incorrectly wired.	Connect pump in accordance with diagram 5.2.
<b>8.2 Main Burner Will Not Light</b>	
External, remote controls not "On."	Check that any remote controls are calling for heat.
Boiler thermostat not on.	Check boiler thermostat is in an "On" position, see also Section 8.9.
<b>8.3 Thermostat Will Not Cut Out</b>	
Thermostat phial not fitted in pocket.	Fit phial in pocket.
Faulty thermostat.	Replace thermostat.
<b>8.4 Overheat Cutoff Cuts Out Prematurely</b>	
Air in heating body.	Vent system. Alter system layout if necessary.
Water circulation low or stopped.	Pump not functioning correctly. Check pump is wired directly to the boiler. Alter system if necessary.
Overheat cutoff operates before boiler cycles on maximum boiler thermostat setting.	Change faulty overheat cutoff.
The correctly set overheat cutoff operates prematurely.	Change faulty heating body.
There is no air in the heating body and water circulation satisfactory.	
<b>8.5 Insufficient Heat</b>	
Thermostat set too low.	Increase setting.
Inlet gas pressure inadequate.	Increase gas pressure.
Governor setting incorrect.	Check burner pressure against data label. Reset only if more than 10% away from required figure.
(ensure thermostat is on maximum setting).	
<b>8.6 Appliance Noisy in Operation*</b>	
Overgassed.	Check burner pressure against data label and adjust only if more than 10% away from stated required figure.
Complete lack of water flow.	Check system controls for correct installation or correct type of controls. Remove air from system. When system is first commissioned the air dissolved may take some time to boil out, therefore attempts should be made to vent air during the first weeks of the installation. Check venting of system, as air bubbles can remain suspended in the water if system is not well vented.
Air in system.	Check that flow rate is correct. Check that pump is correct size and is correctly adjusted. Bypass not fitted or set correctly.
Water flow rate.	

\* There remains on most boilers a residual noise more noticeable at high temperatures. Normal operation of the boiler over a period should remove most noise.

### 8.7 Thermocouple and Overheat Cutoff

To test the thermocouple, a meter with a range of 0 to 30 mV is required.

Symptom: The pilot burner fails to stay alight. Test the thermocouple, overheat cutoff and thermocouple connectors, as described in fault finding chart 8.2, see also diagram 8.1.

Check the millivoltage of the thermocouple closed circuit at points "A" and "E", see diagram 8.1. This should be within the range of 6 to 13mV.

### 8.8 Electrical

Important: The preliminary electrical systems checks in a multimeter instruction book are the first checks to be carried out during a fault finding procedure. On completion of the servicing/fault finding task which has required the breaking and remaking of electrical connections then checks, earth continuity, polarity and resistance to earth must be repeated.

To check the boiler thermostat and multi-functional control (gas valve), see diagram 8.3 and functional flow wiring diagram 8.4.

To check thermostat pump over run circuit see diagram 8.3 and functional flow wiring diagram 8.5.

### 8.9 Pilot

Refer to fault finding for pilot, see diagram 8.5.

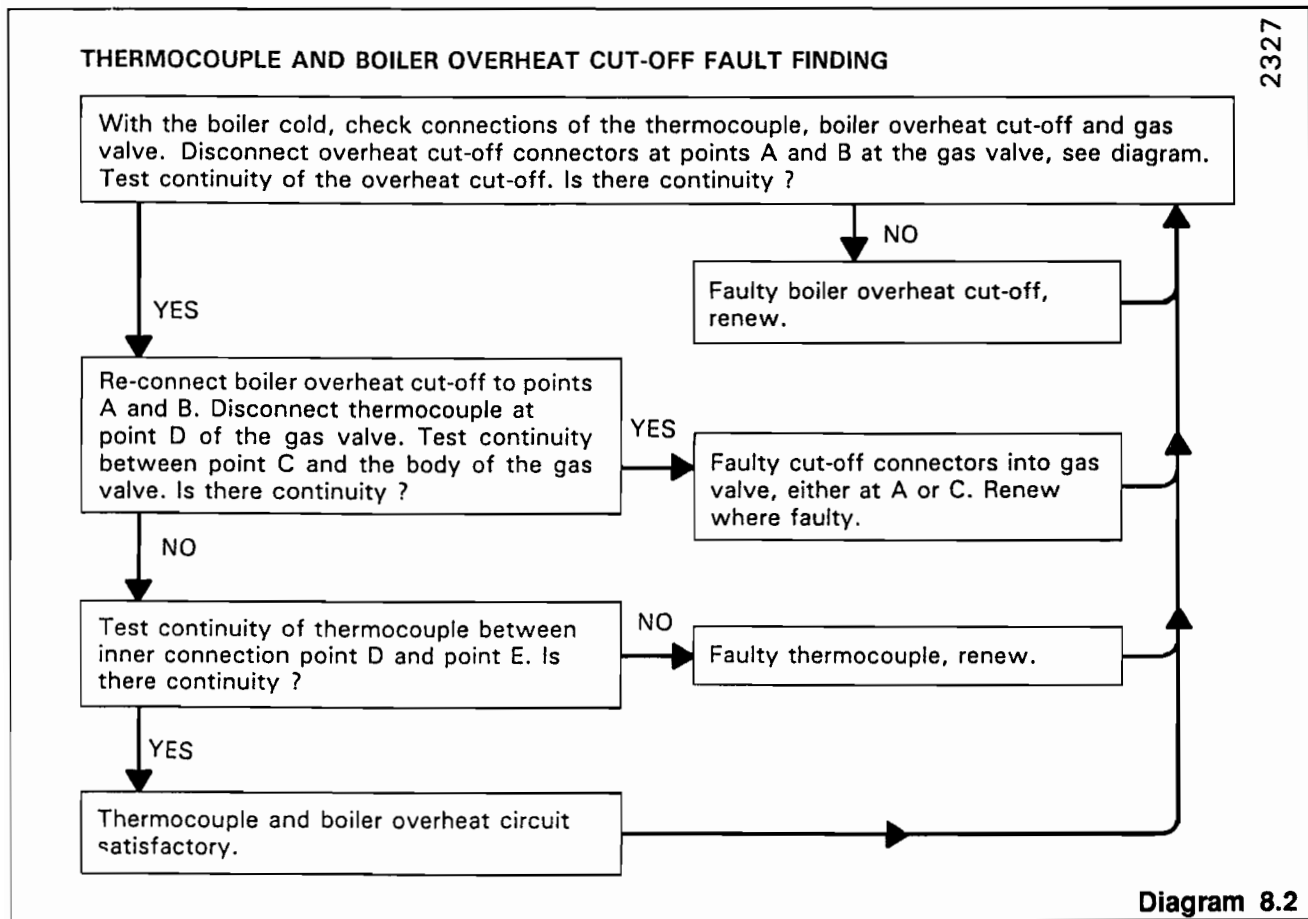
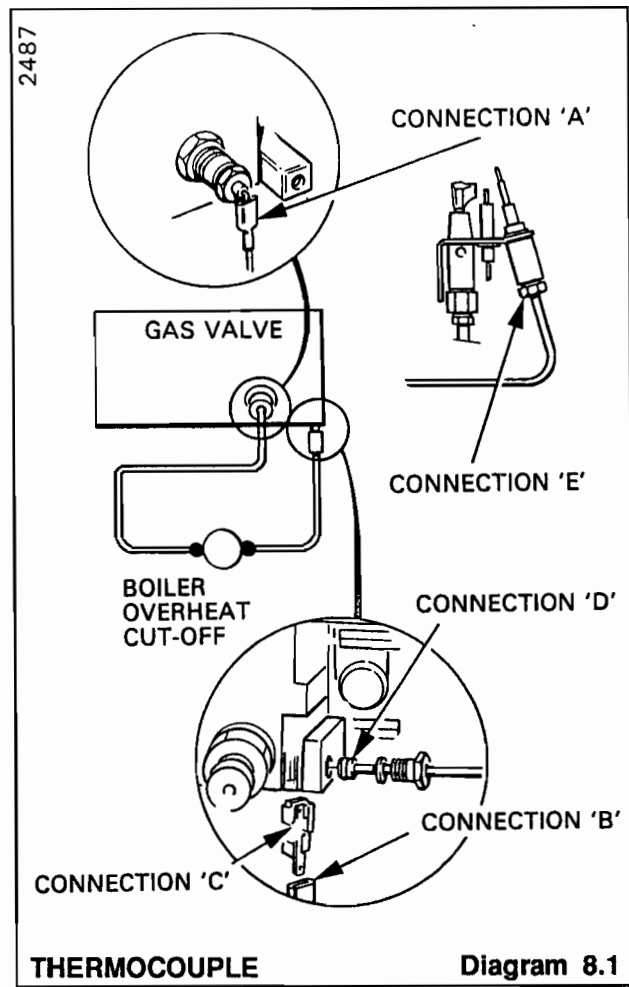

**ELECTRICAL FAULT FINDING**

Ensure that all services are available at the appliance, i.e. Gas, Electricity, Water.  
With Pilot Lit.

START

Isolate the supply. Gain access to the control box, check all connections etc. Restore supply. Using multimeter set at 240V.

Is there 240V between **L** and **N** ?

NO → Check incoming supply and fuses. Repair where required.

YES

Is there 240V between **9** and **N** ?

NO → Faulty Brown bridge wire between **L** and **9** Repair or renew.

YES

With Red Link removed between **9** and **SL** and Remote Controls Calling for Duty is there 240V between **SL** and **N** ?

NO → Faulty Remote Controls, inform customer.

YES

Is there 240V between **9** and **N** ?

NO → Faulty cable (BROWN) from terminal block to thermostat, repair or renew.

YES

Is there 240V between **8** and **N** ?

NO → Faulty cable (RED) from terminal block to thermostat, repair or renew.

YES

Is there 240V between **3** and **N** ?

NO → Faulty cable (RED) from terminal block to thermostat, repair or renew.

YES

Turn on thermostat. With appliance cold is there 240V between **6** and **N** ?

NO → Faulty thermostat, renew.

YES

Turn OFF thermostat. Is there 240V between **6** and **N** ?

YES → Turn ON thermostat. Does main burner light?

NO

NO → Isolate supply. Remove gas valve cover. Restore supply. Is there 240V between 'L' and 'N' on gas valve?

YES → Faulty gas valve, renew.

NO → Faulty gas valve harness, renew.

Turn ON thermostat. With appliance cold is there 240V between **7** and **N** ?

NO → Faulty thermostat, renew.

YES

Turn OFF thermostat. Is there 240V between **7** and **N** ?

YES → Continued

YES

Continued

Continued

Continued

- MAIN TERMINAL STRIP
- THERMOSTAT TERMINALS

2435

Diagram 8.3

## 8 FAULT FINDING

### ELECTRICAL FAULT FINDING CONTINUED

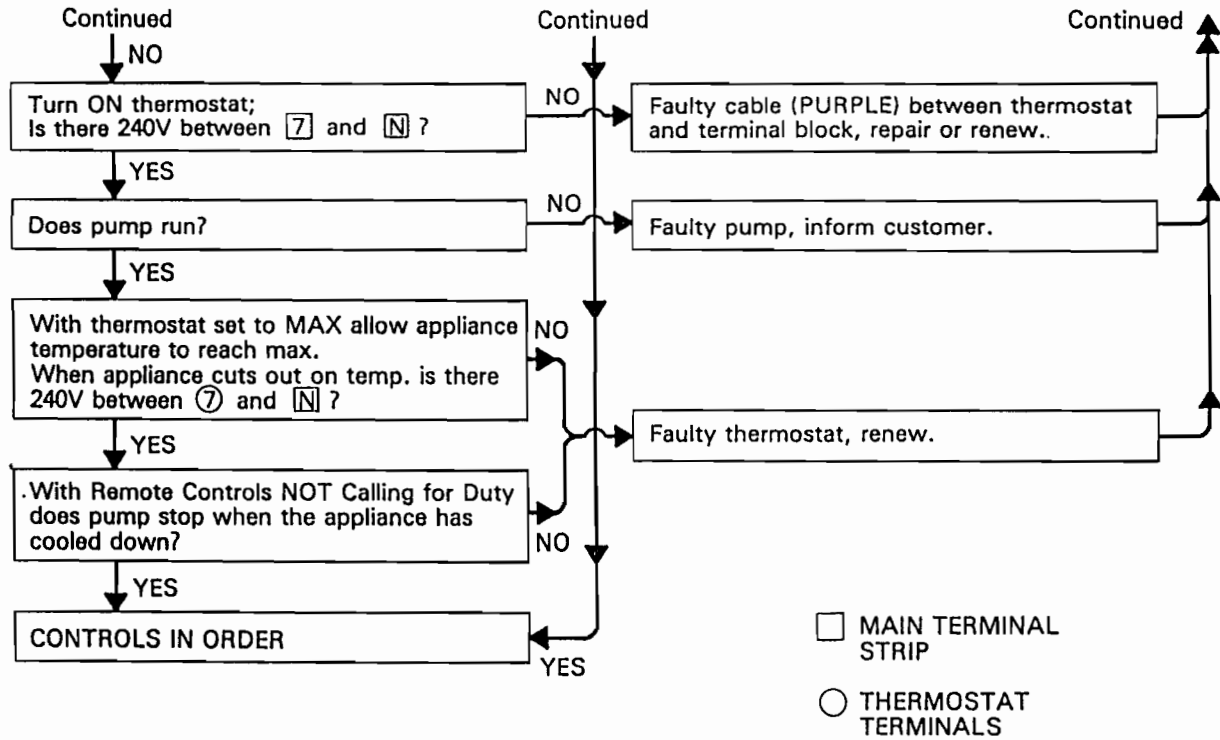

2435

Diagram 8.3 Continued

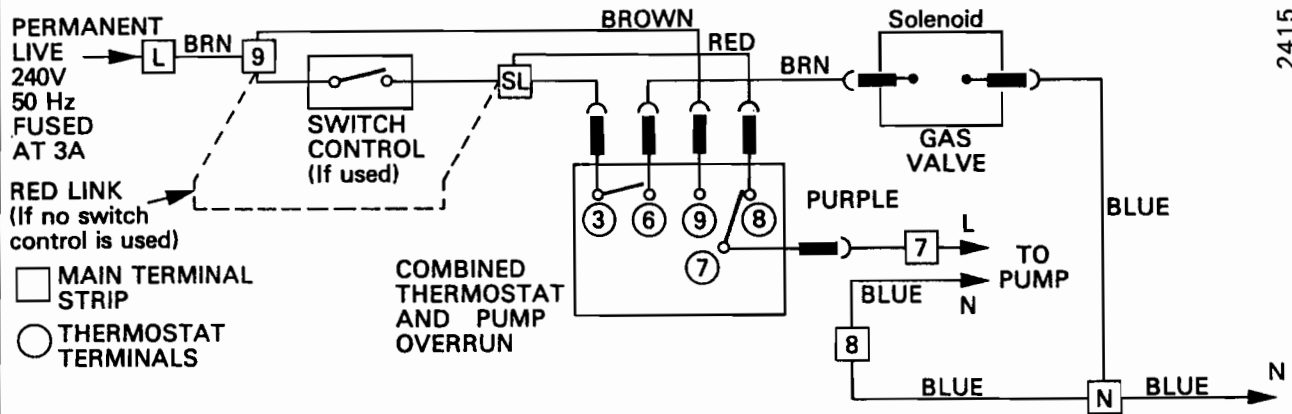

FUNCTIONAL FLOW

Diagram 8.4

2415



PILOT WILL NOT LIGHT  
START HERE

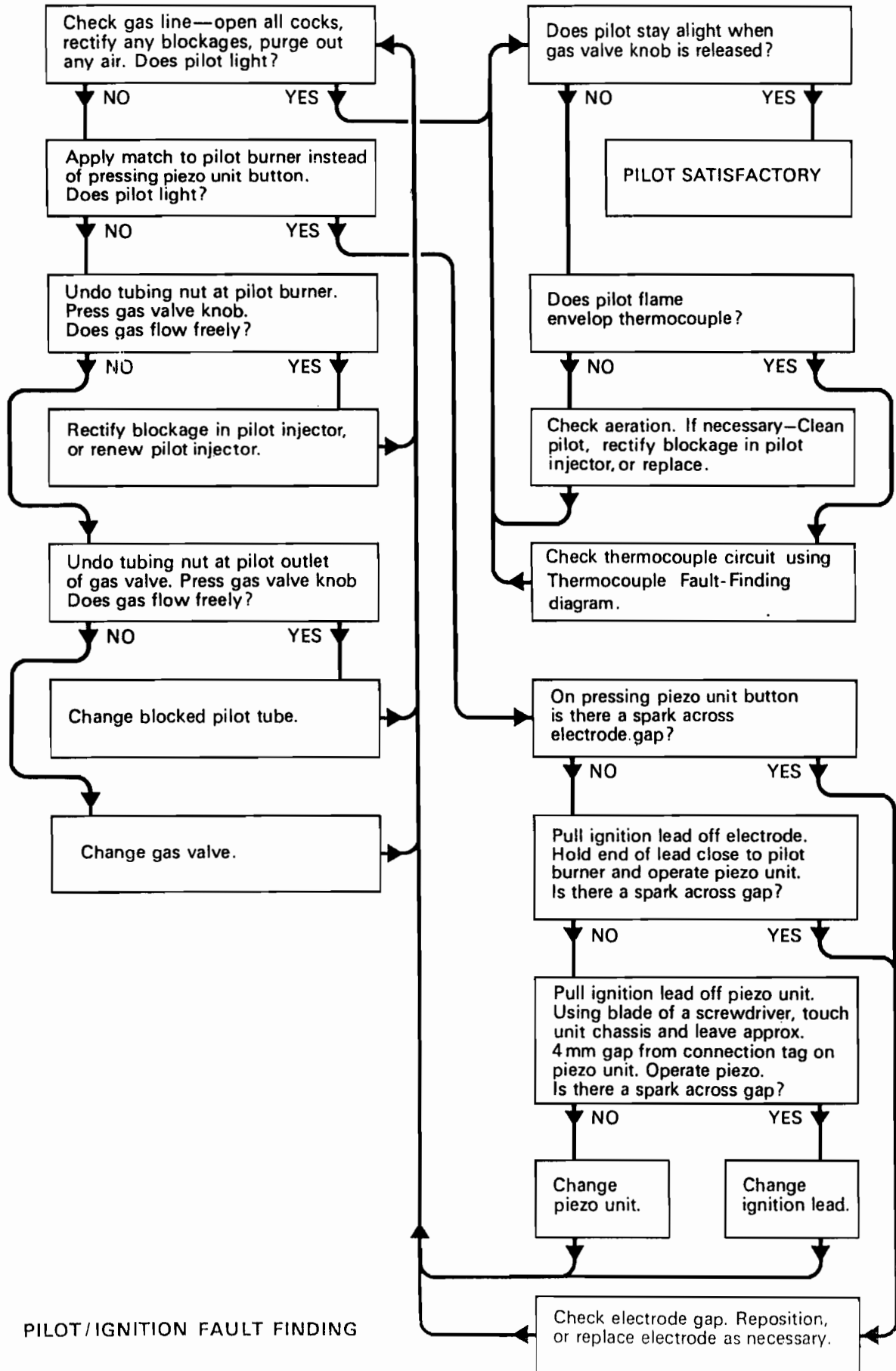

PILOT/IGNITION FAULT FINDING

Diagram 8.5

## 9 SPARE PARTS

### 9 Spare Parts

Key No	Part No	Description	GC No
1	433504	Electrical control box	313 053
2	900501	Piezo unit	*** **
3	416189	Boiler thermostat assembly	355 501
4	800014	Overheat cutoff assembly	313 064
5	800015	Gas valve assembly inc 14	313 067
6	900000	Thermocouple	*** **
7	203415	Pilot burner inc 12	394 161
8	202600	Electrode	384 149
9	416144	Thermostat knob	355 401
10	WW4612	Ignition lead	355 500
11	203042	Injector main - 30R	398 674
	203035	Injector main - 40R	398 675
	203040	Injector main - 50R	398 513
12	203509	Pilot Injector- Johnson	-
13	411194	Sight glass	355 153
14	208040	'O' Ring- gas valve/2 off	

### 9.1 Ordering

When ordering spare parts, quote the part number, description, serial number and model name from the plate on the boiler, see diagram 6.1.

9 SPARE PARTS

2422

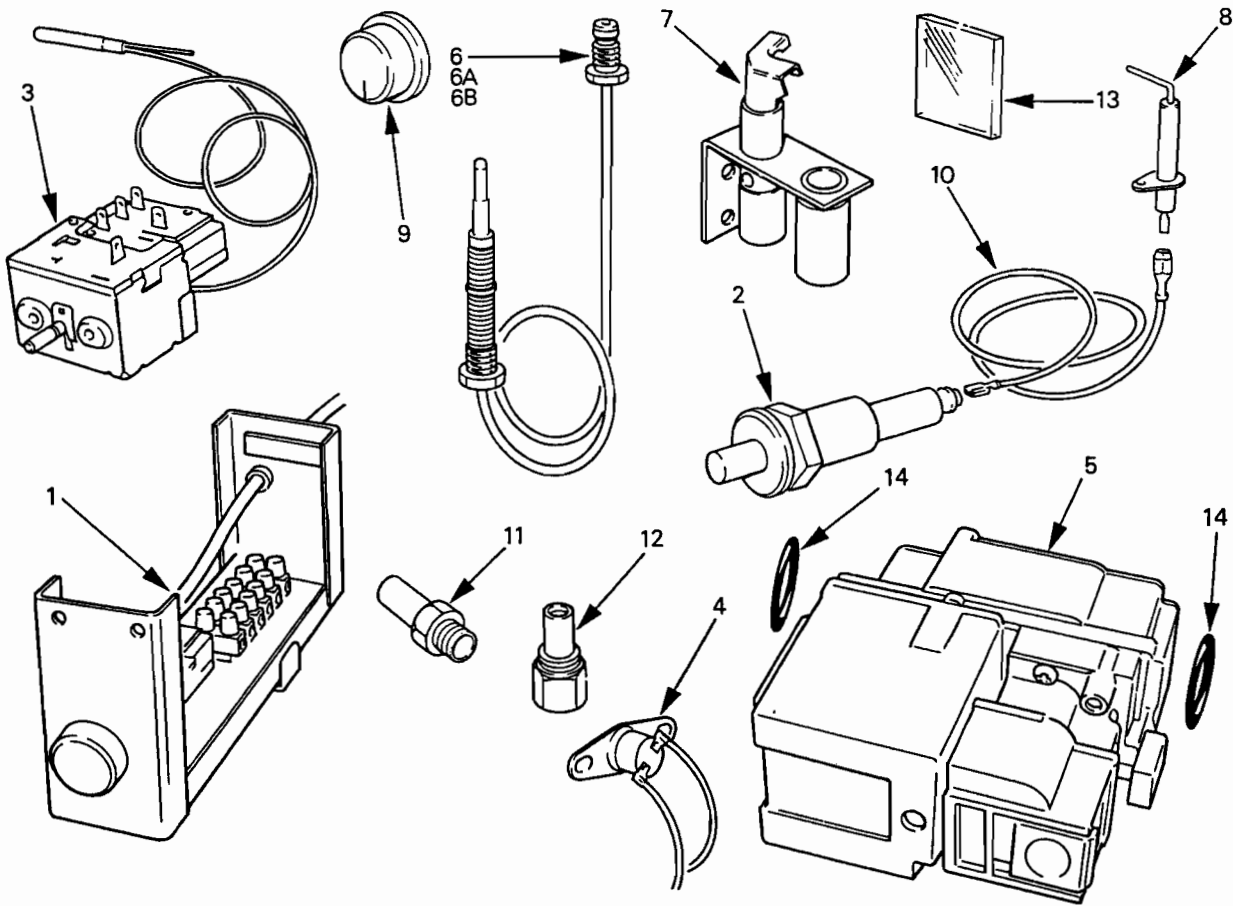

Diagram 9.1

*Because of our constant endeavour for improvement details may vary slightly from those in the instructions.*