



KOMPLET
a.s.

Project data (version 1.1)

Semechnice 132, 518 01 Dobruška
Tel./fax +420 494 664 203
Tel. +420 494 664 201
E-mail: pzp@pzp.cz
<http://www.pzp.cz>

TCLM KOMPLET Heat Pumps



1. General – Application

The **TCLM KOMPLET heat pumps** are designed to mainly serve as a heating source for the heating of family houses.

The characteristic feature of the heat pump is its ability to transform - with the aid of electric energy – low-potential heat from ‘natural’ sources that cannot be utilized in common ways (for instance, heat from the ambient air, soil, or ground water) to heat suitable for heating. The principle of the heat pump implies that the heating output to electrical input ratio (so-called performance factor) is always greater than one, which means that heating output is always greater than electric input. The economical convenience of the heat pump – i.e. the greater the temperature of the low-potential heat and the lower the temperature of the heating medium, the greater the amount of the thermal energy produced from taken electric energy. The heat pump is therefore suitable especially in combination with low-temperature heating systems (for instance, under-floor heating or wall heating and large-surface radiators).

2. Characteristic Features – Heating System

The **TCLM KOMPLET heat pumps** are designed as ‘air-water’ pumps, i.e. the source of their low-potential heat is the ambient air that is supplied by means of air pipelines to the heat pump. The heating output from the heat pump is removed through a circulation circuit filled with water that functions as a heating medium.

Considering the relation between the need for heat and energy consumption needed for heating during the heating season it is recommended that a **heating system with a heat pump** is designed as a **bivalent** system, i.e. that the heat pump alone is able to cover the need for the heat, or rather heating output, only up to a certain outside temperature, for instance, for instance 0°C (so-called bivalence temperature), whereas it cooperates with another heat source such as a direct-heating electro-boiler at lower temperatures. Given the relatively short duration of the period with low temperatures when a greater output than that provided by the heat pump is required, the other source contributes to the coverage of the total need for heat by as little as 10 to 20 %. The so-designed heating system achieves an optimal ratio between acquisition and operational costs and can bring **savings of as much as 65 % of paid electric energy needed for heating**.

The TCLM KOMPLET heat pumps work with the **SCROLL compressors** and with an absolutely ecologically safe cooling agent called **R 404A**. The plus side of the heat pumps with these compressors and with this type of cooling agent is the fact that the decline of heating output and performance factor depending on the drop of the outside temperature is very mild. Unlike rated values at the outside temperature of 0 °C, heating capacity and performance factor drop by about 30% at the outside temperature of –15 °C.

3. Working Principle

The working principle of the heat pump is a so-called cooling circuit with steam circulation. The heat pump, or rather the cooling circuit has four basic parts:

□ Evaporator

Low-potential heat is supplied to the evaporator through the ambient air. The supplied heat causes the cooling agent to evaporate; the vapors of the cooling agent thus become the carrier of thermal energy, which they transport to the compressor. The air whose circulation through the evaporator is secured by an axial ventilator or ventilators is being cooled at the same time. The air path forms the **primary circuit of the heat pump**.

□ Compressor

The compressor absorbs vapors from the evaporator, compresses them and delivers them to the condenser. The work developed to drive the compressor is transformed into heat that is added to the heat supplied to the evaporator.

□ Condenser

The circulating working substance (heating medium) removes from the condenser the heat that was supplied to the same from the evaporator and the compressor by cooling agent vapors.

The removal of the heat causes the vapors of the cooling agent to condense. The transferred heat warms up the working substance that is, once it has been warmed up, introduced into the heating system. The required circulation of the working substance is secured by the **secondary circuit of the heat pump**.

□ **Choke valve**

The liquid cooling agent that condensed in the condenser at a greater (condensation) pressure is transferred (choked) into the evaporator to evaporate there again at a lower (evaporation) pressure.

4. Technical Description

The **TCLM KOMPLET** heat pump (hereinafter referred to only as ‘the heat pump’ or the ‘TCLM KOMPLET heat pump’) is designed as a complete bivalent source fitted with an additional electro-boiler and a circular pump so it can be connected directly to an accumulation tank or to a thermo hydraulic distributor. The heating medium outlet from the electro-boiler is fitted with a three-way distributing valve with a slave drive, thus providing the hop with two heating medium outlets. The first outlet is designed for heating, the other the heating (or preheating of) **Hot Service Water**. The preheating of HSW can be used all year. During the heating season the preheating function is utilized during a heating delay period. When this type of connection is applied, the **temperature of the preheated HSW and of the heating medium** are absolutely **independent of each other** and both functions are executed with an optimal energetic effect. This proves convenient especially in case of under-floor heating and during equithermal regulation (that is secured by the control system) when heating is secured by a heat pump that works with the low – i.e. energetically optimal – temperature of the heating medium and only when preparing HSW of greater temperature.

The switchboard can be connected with all other necessary operation and controlling system components, especially: a circular pump for the heating system, an electrical heater for the additional heating of HSW, a room thermostat in a reference room, a sensor monitoring the temperature of HSW TUV and three independent signals of CRC (applicable to the heat pump, electro-boiler, and electrical heater for the additional heating of HSW).

The control system communicates with an operator by means of a two-line display and several control elements. The system works with so-called auto diagnostics that monitors all important operational statuses and whenever limit statuses are exceeded it signals a failure and its cause and shuts down the respective part of the equipment (i.e. of the heat pump or the electro-boiler).

A **new, energetically efficient method of defrosting** is applied to melt away the ice that forms on the evaporator when the outside temperature drops below approx. 8°C. The heat pump also includes an accumulation tank with a heat exchanger integrated in the heat pump circuit. The filling of the tank that contains non-freezing liquid secures – in a thermodynamically convenient manner - the accumulation of heat required for defrosting while the pump is in operation. During the defrosting, necessary heat is taken from this tank and does not have to be removed from the heating system or supplied directly by electric energy, which is a common design applied to the most types of defrosting.

The heat pump is placed in a suitable interior – i.e. the machine room of the heating equipment.

Commissioning is possible after the proper connection of the heat pump to the outside secondary circuit, after connection to the mains supply and after connection with the other elements within the heating system.

The heat pump circuit is assembled in a self-contained tin cabinet that is thermally insulated and fully noise-proof on the evaporator side. It also includes switchboard **with control panel that operates** as both power switchboard and a **control system for the entire assigned heating system**.

The most relevant requirements that determine the parameters and operational reliability of the heat pump are indicated in highlighted paragraphs.

5. Cooling circuit

The cooling circuit (read paragraph 3. ‘Working principle’) consists of a hermetic spiral compressor - SCROLL, plate condenser and a tubular evaporator; the supply of the coolant to the evaporator is controlled by a thermostatic expansion valve.

All of the parts of the circuit are interconnected with copper piping that is fitted with other necessary integrated components.

The compressor is located on rubber vibration compensators. At rest, its cabinet is heated with an electrical heater, which prevents the saturation of oil with the coolant. This ensures reliable operation and extends the compressor's service life.

The plate condenser is made of brazed stainless plates that form a sole, non-dismountable whole of high strength. The special system of channels between the plates induces intensive turbulent flow that guarantees the extensive penetration of heat in the exchanger. The turbulent flow along with the smooth surface of the plates reduces the risk of the sedimentation of impurities.

The tubular evaporator is made of copper tubular coils. The outside wall of the heat-exchange surface (the air side) is enlarged with aluminum lamellas. The flow of the air through the evaporator is secured by an axial fan or fans. The evaporator is vertical.

The thermostatic expansion valve is a valve with external pressure balancing and with a so-called MOP.

External pressure balancing eliminates the pressure loss of the evaporator to the control variable of the valve, i.e. to the overheating of vapors leaving the evaporator. Evaporation temperature (measured by means of evaporation pressure) is not read in the place of valve fitting (i.e. in front of the evaporator), but in the place of the measurement of overheating, or rather in the place of the measurement of the temperature at the evaporator outlet (i.e. behind the evaporator).

The valve with MOP (**Maximum Opening Pressure**) makes sure that if the equipment is started while hot, the evaporation pressure (and temperature) will not go up beyond a certain value (that is determined by the respective value of MOP), thus preventing the overloading of the equipment, especially the overloading of the electromotor of the compressor as well as of the condenser that results in an increase of condensation pressure in excess of an admissible value (beyond which the operation is blocked by the high-pressure part of a combined presostat).

Evaporator melting. When the air on the evaporator cools off, the humidity on its surface condenses. At really low outside temperatures, the same humidity on the heat-exchange evaporator surface freezes and forms ice that is melted periodically. At a temperature greater than about 8 °C, the melting is secured by circulation through the evaporator or evaporators – by the 'running-out' of the fans after the heat pump's shutdown. At a lower temperature, the melting is accomplished by means of the nonfreezing liquid from the heat pump accumulation tank.

The cooling circuit is fitted with other components that secure the reliability and safety of its operation. These components are a liquid coolant collector, filter dehydrator, and indication eyehole.

The proper operational conditions (suction and delivery pressure and temperature at the compressor delivery) follow the combined presostat (low-pressure/suction side and high-pressure/delivery side) and the thermostat. If proper operational conditions are not observed, the equipment turns off and a failure is signaled on the control panel.

The cooling circuit works with an absolutely ecologically safe coolant called R 404A.

6. Heat pump primary circuit

The primary circuit secures the supply of low-potential heat to the heat pump.

The supply of the outside air to and the removal of the cooled air from the heat pump is secured by flexible piping with an insulation layer whose minimal thickness is 25 mm. The dimension of the inner diameter of the air pipeline is, depending on the heat pump's capacity, either 356 mm or 406 mm. The heat pump's inlet and outlet are fitted with doubled collars to which the respective parts of the flexible piping are attached. The inlet and the outlet at the limit of the premises shall be provided with a bushing with a grill (see the dimensional sketch). For further detailed description please read chapter 11, picture 1a. The insulated flexible piping, the bushings with a grill and tightening clips are included in the delivery of heat pump accessories.

It has been said in this information that low-potential heat is obtained by cooling the ambient air. The cooling of the air leads to the condensation of humidity that gets frozen on the evaporator. The ice melts periodically and automatically as described above. The melted ice drips (runs) freely from the vertically placed evaporator into a stainless tub under the evaporator. The tub is provided with a dis-

charge opening located in the lower part of the heat pump. This opening should be fitted with a siphon that is included among heat pump accessories. The outlet is made of a copper pipe with a diameter of 22 x 1 mm. The melted ice is removed into a suitable waste trap that can be installed directly under the heat pump or in its vicinity. In this case the outlet is extended by means of a hose.

Near the heat pump, a waste trap must be made available to be connected with waste piping that removes the humidity condensing on the evaporator, or rather the melted ice from the evaporator.

7. Secondary circuit

The secondary circuit secures the transfer of the heat pump's heating output to the heating system.

The internal connections of the leads of the secondary circuit in the heat pump are made of the Hostalen material. The inlet and outlet tube sockets are fitted with a copper pipe that is 28 x 1.5 mm (see the dimensional sketch).

The secondary circuit and a necessary circular pump in the heating system, or pumps are not included in a heat pump delivery.

7.1 Circulation circuit proper

In order to secure the heat pump's parameters according to this documentation and operational safety, the secondary circuit must meet the following requirements:

- The circular pump that is a part of the heat pump must, at a required flow rate, provide for the coverage of the pressure losses of the entire circuit, including the internal pressure loss of the heat pump on the condenser side.
- The flow rate of the working substance (heating medium) must be constant and must correspond with this documentation.
- In order to adjust a flow-rate amount a flow meter and appropriate regulation armatures must be installed within the circuit (at least for adjustment during commissioning).
- If the flow meter is not installed permanently, thermo cells must be installed at the circuit inlet and outlet so that the flow rate can be verified indirectly according to a change in the temperature of the medium in the heat pump (as per this documentation).
- An efficient filter must be fitted in front of the heat pump's inlet socket; the filter captures impurities from the outside parts of the circulation circuit and prevents the possible contamination of the plate heat exchanger. The filter is mounted outside the heat pump to allow for easy inspection and cleaning.
- The circuit must be designed so that it can be vented perfectly.
- Measures must be taken inside the circuit to eliminate the volumetric changes of the working substance (heating medium) depending on temperature changes.
- The circuit must be secured in accordance with valid standards for heating systems
- The connection of the outer circulation circuit must be completed with removable joints one side of which must be welded onto the neck of the TCLM KOMPLET pump.
- The dimension of the outer pipelines is calculated according to the 'flow rate – pressure loss' relation, it is not chosen according to the dimension of the heat pump neck.

7.2 Heat pump in a heating system

In order to ensure the reliability of the heat pump (i.e. of the cooling circuit) in a heating system the following basic requirements must be met:

- The temperature of any part of the secondary circuit must not exceed 55 °C.
- The flow rate of a heating medium through the TCLM KOMPLET heat pump must be constant and the flow rates of the heating medium through the heat pump and the heating system must be absolutely independent of each other.
- The frequency of the switching of the heat pump must not be greater than 4 startups per hours.

Considering that the heating system works:

- Either with the variable flow rate of the heating medium (a system with thermoregulation valves or a zone-divided system),

- Or with a variable inlet temperature (a heating system whose inlet temperature is controlled by a mixing valve);

whereas both of these conditions are inappropriate for heat pumps, it is necessary to provide for the independent flow of the heating medium through the heat pump and the heating system.

This basic requirement is satisfied by securing the flow rate in both parts by means of independent circular pumps, i.e. by installing one independent circular pump for the heat pump and another one for the heating system. At the same time both pumps (i.e. also the pump used by the heating system) must be sized for a flow rate amount required by the heat pump and both parts must be interconnected either with a thermo hydraulic distributor or with an accumulation tank in order to make sure that there is an independent flow in both segments.

The heat pump's output within a heating system is controlled in a two-positional manner, i.e. 'on and off'. The frequency of switching depends mainly on the heating system's design, its regulation, total filling of the heating medium in the heating system, and the ability of such a filling to accumulate heat; whereas the frequency derives from the following facts:

Within a heating system the heat pump represents a heat source and a selected heating system represents heat consumption. Because the heat pump alone does not have output regulation, the disproportions between the source's output and consumption is resolved by heat accumulation in the heating system's filling, or rather in the heating system's active segment. The smaller the active filling and the heat accumulation of the system, the greater the frequency of switching. The term 'active filling' means a minimal system filling that circulates in the heat pump under any working (regulation) status of the heating system. If the active filling of the system is not sufficient, it has to be secured by an accumulation tank.

If the heat pump's heating output is not fully utilized, the heat pump operates in working cycles when:

- During the first cycle part the heat pump is engaged in operation, heat accumulates in the system's filling, and the system is being 'charged' (by the surplus output of the source as opposed to the output of the consumption part);
- During the second cycle part the heat pump is disengaged, the accumulated heat is taken from the system's filling, and the system is being 'discharged'.

The following relation can be derived for a maximum of 4 activations of the heat pump per hour with regard to the minimal **active filling of the heating system** V_a [liters] in which the TCLM heat pump operates with heating output Q_z [kW]:

$$V_a \text{ [liters]} = 15 \times Q_z \text{ [kW]}$$

The questions connected with the frequency of switching are considered when there are reduced requirements for heating output, i.e. at the higher temperatures of the outside air (above a bivalence temperature level). When higher requirements for heating output are in place, i.e. when the temperature of the outside air is lower (below a bivalence temperature level), the heat pump works permanently and its output is complemented by the other source.

In order not to exceed the frequency of switching, the control system of the heat pump is provided with so-called anticyclic regulation that prevents the repeated startups of the cooling circuit within short time intervals.

It is often the case in a heating system with poor heat accumulation that if there are lower requirements for heating output, the frequency of switching is not determined by controlling temperature by anticyclic regulation.

The proper solution of issues connected with the system's accumulation capacity has great importance for the full utilization of the heat pump.

The heating system must be secured in accordance with valid standards for heating systems.

7.3 Connection of a heating system with the TCLM KOMPLET heat pump

The principle of the connection of a heating system with the TCLM KOMPLET heat pump is shown in pictures 1a, and 1b. Picture 1a features the interconnection of the system and its function during the 'heating' mode. Picture 1b shows the interconnection of the system and its function during the 'HSW preparation' mode. Both pictures imply that the connection procedure is quite easy from

both the mechanical (heating installation) and electrical points of view. The important element is the fitting of the freely accessible and cleanable filter at the inlet of the heating medium to the heat pump.

The TCLM KOMPLET heat pumps above-referenced designed so that they could also be used in nonstandard situations, especially:

- When using a boiler burning natural gas or liquid propane, or ecological heating oil as a bivalent source;
- In existing heating system with a direct heating electro-boiler or with sources according to the previous paragraph.

The principle of such connection is shown in picture 2. With the existing types of heating system a qualified technical designer must consider whether the heating system, the leads of the heating medium, and the circular pump or pumps will be suitable for the heating system with a heat pump, or he has to specify modifications necessary for their use. He shall further define a way in which both systems should be connected with power cables as well as a method of connecting the existing system to the control system of the TCLM KOMPLET heat pump.

7.4 Working substance

Water is considered the unquestionable working substance (heating medium) of the secondary circuit.

8. Control panel, power switchboard, and control system

The switchboard has controlling function over the heat pump but it also works as its power switchboard. The switchboard must be connected to the parent control system of the heating system.

The switchboard is equipped with a main switch.

The switchboard of the heat pump secures the control of the entire heating system as well as of the equipment for HSW preparation.

8.1 Control system

The control of the heat pump and its automatic operation is secured by a **MicroTC programmable microprocessor regulator** in connection with an operation panel that communicates with the operator, monitors the important parameters and operational statuses of the heat pump and shows the same on the display or signals it through the indicator lights on the panel. The complex control of the heating system from the heat pump's control panel is secured by the **RVS14 programmable microprocessor regulator**.

If the important operational values exceed limit values, the heat pump turns off and the regulator display (operator panel) signals a respective 'failure', i.e. the reason for the heat pump's shutdown.

The operator panel of the heat pump contains:

- Equipment on/off button (introduction of an emergency status)
(When the heat pump is turned off the heating of the compressor is not on.);
- Buttons for communication with heat pump operators;
- Display for the imaging of the parameters and operational statuses of the heat pump;
- Color indicator lights for the direct imaging of the heat pump's operational statuses (failure, electrical feeding status, compressor activity, operational mode).

The detailed description of the control panel and of the heat pump's operation is not a part of these designing data and information.

The regulator monitors:

- a) The following **operational statuses**
 - Delivery (condensation) pressure,
 - Suction (evaporation) pressure,
 - Compressor delivery temperature,
 - Correct order of phases and full voltage in all of them,
 - Correct progress of evaporator melting,

- Requirement for the operation of the heating system in the first (second, or further) zone of the heating system defined by a room thermostat in the reference room of the first (second, or further) zone,
 - Requirement for the preheating of HSW by a heat pump,
 - Requirement for the additional heating of HSW by an electrical heater,
 - Approval to operate a heat pump by a CRC signal,
 - Approval to operate an electro-boiler by a CRC signal,
 - Approval to operate the additional heating of HSW by a CRC signal,
 - Exceeding of the electro-boiler's safe temp.
- b) Following **parameters**
- Temperature of (return) heating medium at the heat pump inlet,
This temperature is the controlling variable of the heat pump according to which the operation of the heat pump is controlled (on/off),
 - Controlling temperature of the heating medium (the temperature of the return medium from the heating system); the operation of the heat pump and of the additional (bivalent) heat source depends on this temperature,
 - Temperature of heating medium at the heat pump outlet,
 - Immediate temp of the supplied outside air,
 - Temperature of the surface of the heat-exchanging area of the evaporator,
 - Compressor temperature,
 - Daily average temperature of the supplied outside air,
 - Temperature of the heating medium behind the mixing section (if it is applied),
 - Operational clock of the heat pump and of the electro-boiler.

If any of the statuses or parameters exceeds a limit value, the equipment is disengaged from operation and the display signals a respective 'failure'. A failure can also be signaled acoustically. A failure status can also be led outside the control box.

The regulator also secures the following:

- Delayed startup of the heat pump after connecting feeding voltage or after activating an emergency status (approximately 1 minute),
(This prevents undesirable repeated activations occurring during mains supply failures or improper handling of wiring),
- Anticyclic regulation that secure necessary delay between two starts of the compressor or of the regulation outlets of the electro-boiler (min. 15 minutes),
- Regulation of the minimum shutdown time of the compressor or of the regulation outlets of the electro-boiler (min. 5 minutes),
- Minimal delay between the activation of two regulation outlets,
- Melting of the evaporator within a set time mode and depending on outside temperature and on the surface temperature of the evaporator,
- Blocking of the operation of the electro-boiler in the automatic mode according to the outside temperature (according to the bivalence temperature),
- Activation of the electro-boiler as a substitute heat source in the event of a heat pump failure,
- Continual activation of the regulation outlets according to the controlling temperature of the heating medium.

8.2 TCLM KOMPLET switchboard connection

Power feeds:

- X0: U0, V0, W0, N, guard wire – main power feed 3 x 400 V, 50 Hz; not fused in the TCLM KOMPLET switchboard. Sizing and line protection – read paragraph 8.3.
- X0: U2, N2, guard wire – auxiliary power feed for the single-phase heater for HSW heating, not fused in the TCLM KOMPLET switchboard. Sizing and line protection according to paragraph 8.3. If the auxiliary power feed for the single-phase heater in a boiler is not introduced or when using a three-phase heater for the electrical heating of HSW, it is necessary to connect terminals X0: U1 with U2 and X0: N with N2.

Power terminals:

- X1: 22, 23, 24, guard wire – fused terminal for the connection of a three-phase coil for the additional heating of HSW, load capacity – up to 6 kW
- X1: 22, N2, guard wire – fused terminal for the connection of a single-phase coil for the additional heating of HSW, load capacity 3 kW
- X1: 27, N, guard wire – connection of the circular pump (230 V, 50 Hz) of the heating circuit 1, or also connection of a two-positional action element (230 V AC) for the spontaneous change of the configuration in the first zone of the heating system; load capacity – up to 300 W
- X1: 28, N, guard wire – connection of the circular pump (230 V, 50 Hz) of the heating circuit 2, or also connection of a two-positional action element (230 V AC) for the spontaneous change of the configuration in the second zone of the heating system; load capacity – up to 300 W
- X1: 29, N, guard wire – connection of a circular pump (230 V, 50 Hz) for the connection of the circular pump of HSW preparation; load capacity – up to 300 W

Nonstandard manufacturing versions with more than two circuits of the heating system (a maximum of 6 circuits)

- X1: 30, N, guard wire – connection of the circular pump (230 V, 50 Hz) of the heating circuit 3, or also connection of a two-positional action element (230 V AC) for the spontaneous change of the configuration in the second zone of the heating system; load capacity – up to 300 W
- X1: 31, N, guard wire – connection of the circular pump (230 V, 50 Hz) of the heating circuit 4, or also connection of a two-positional action element (230 V AC) for the spontaneous change of the configuration in the second zone of the heating system; load capacity – up to 300 W
- X1: 32, N, guard wire – connection of the circular pump (230 V, 50 Hz) of the heating circuit 5, or also connection of a two-positional action element (230 V AC) for the spontaneous change of the configuration in the second zone of the heating system; load capacity – up to 300 W
- X1: 33, N, guard wire – connection of the circular pump (230 V, 50 Hz) of the heating circuit 6, or also connection of a two-positional action element (230 V AC) for the spontaneous change of the configuration in the second zone of the heating system; load capacity – up to 300 W

Control inlets:

- X2: 33 – neutral wire of the CRC relay for HSW – gives an approval to operate HSW electrical heating,
- X2: 34 - neutral wire of the CRC relay for the electro-boiler - gives an approval to operate the electro-boiler,
- X2: 35 - neutral wire of the CRC relay for the heat pump - gives an approval to operate the heat pump,
- X2: 36, 37 – first zone room thermostat (potential-free contact), when the temperature in a reference room drops, it starts the circular pump of the first zone of the heating system and submits a requirement for the operation of the heat pump; if the temperature is lower than a required temperature, the outlet of the room thermostat must be switched on non-stop.
- X2: 38, 39 – second first zone room thermostat (potential-free contact), when the temperature in a reference room drops, it starts the circular pump of the second zone of the heating system and submits a requirement for the operation of the heat pump; if the temperature is lower than a required temperature, the outlet of the room thermostat must be switched on nonstop.
- X2: 49, 50 - thermostat for the preheating of HSW by means of the heat pump in a floating boiler (potential-free contact), if the monitored temperature falls down, it starts the operation of the heat pump.

Nonstandard manufacturing versions with more than two circuits of the heating system (a maximum of 6 circuits)

- X2: 51, 52 – third zone room thermostat (potential-free contact)
- X2: 53, 54 – fourth zone room thermostat (potential-free contact)
- X2: 55, 56 – fifth zone room thermostat (potential-free contact)
- X2: 57, 58 – sixth zone room thermostat (potential-free contact)

Analog inlets:

- X3: 81, 82 – probe for measuring the controlling temperature of the heating medium. If the probe is not installed, the temperature measured at the heat pump inlet is used as controlling temperature by default.
- X3: 83, 84 - probe for measuring the temperature of HSW in a boiler with additional electrical heating. If the probe is not installed, the functions of preheating and of the additional electrical heating of HSW in the boiler are not activated.
- X3: 85, 86 - probe for measuring the temperature of the medium behind the mixing section. If the probe is not installed, the function of an analog outlet for a mixing valve is not activated.

Analog outlet:

- X3: 87 (controlling voltage 0-10V), 88 (feeding 24 V AC), 89 (joint pole) – terminals for the connection of a continuous slave drive with a voltage of 24 V AC.

8.3 Sizing and fusing of the TCLM KOMPLET main feed

The sizing and fusing of the main feed to the TCLM KOMPLET heat pump is closely connected with the sizing of the bivalent source. Related issues are important especially in the most frequent types of an electric bivalent source; i.e. when an electro-boiler is used as an additional source (EB). If the heating system with a heat pump is expected to secure not only a **reduction in electricity consumption but also a reduction in power supply**, the bivalent source must comply with the following requirements:

- Additional source (electro-boiler – the same applies to a gas boiler) also works as a backup source in the event of a heat pump failure.
- The full capacity of the electro-boiler can be used only during a heat pump failure.
- While the heat pump is operating, only that part of the electro-boiler can be used ('free electro-boiler capacity') that covers the disproportion between the heat pump's output and a necessary heating output at a calculation temperature.

The remaining part of the electro-boiler's capacity must be blocked, and the capacity of the individual stages of the electro-boiler must be adapted to meet this requirement as well.

- 'Free electro-boiler capacity' is available only when the outside temperature is lower than the temperature of bivalence.

The control system of the TCLM KOMPLET heat pump secures the logic described above. The system controls three stages of the electro-boiler; at least one of them being blocked. These conditions must be met not only by the division of the electro-boiler into three stages but also by the adjustment of the regulator.

The design of the heating system, **the choice of the output of the heat pump and of the electro-boiler, the sizing and fusing of the main feed affect the choice of a circuit breaker in the electro-metering switchboard**. The size of the circuit breaker determines the permanent monthly payment of electricity **and** affects **operational costs**. This is why all of these facts should be given proper and serious consideration.

Basic relations between the sizing of the main feed and a maximal admissible input during the operation of the electro-boiler alone and during the simultaneous operation of the heat pump and of the electro-boiler, or also of the electrical heating of HSW, depending on the size type of heat pump are obvious from a table entitled 'Main feed sizing'.

If a boiler with HSW electrical heating (additional heating) is integrated in a heating system HSW the following applies:

- If a three-phase heater is installed, it is necessary to add its output to the total output of the electro-boiler, or rather to 'the free output of the electro-boiler' EB. The main three-phase feed to TCLM KOMPLET is shared by the heat pump, electro-boiler and the heater of the boiler.

- If a single -phase heater is installed, it is necessary to use an independent, fused single-phase feed to TCLM KOMPLET for its feeding (read paragraph 8.2). The sizing of this feed for the maximum input of the heater of 3 kW is 3C x 1.5; line protection B 16 A.

8.4 Controlling signals of collective remote control (CRC)

The TCLM KOMPLET heat pump is designed to provide independent control of three devices by three CRC signals.

The independent control of the following equipment is thus secured:

- Heat pump proper
- Electro-boiler working as an additional bivalent source
- Electrical heating (additional heating) of hot service water (HSW)

The scheme of electric leads must provide for necessary cabling in order to transfer three CRC signals via neutral conductors (see terminals X2: 33, 34, 35) from the electro-metering switchboard to the TCLM KOMPLET heat pump.

9. TCLM KOMPLET heat pump manufacturing

The TCLM KOMPLET heat pumps are supplied in a manufacturing version that is suitable for both heating systems with large-surface radiators and under-floor heating. Depending on the design of connecting air pipelines, either a 'left' or 'right'-handed heat pump can be chosen. The difference between these two versions is in the direction of the airflow through the heat pump. In addition to the above-described standard version of the TCLM KOMPLET heat pumps, these pumps can also be supplied without an electro-boiler and a distribution three-way valve. Such a solution is purposeful when applied in connections with an existing, standard heat source that will be subsequently used a bivalent additional source.

It applies that when the working temperature is greater than a bivalence temperature the heating system will work with a lower inlet temperature than designed and it will provide a reduced required heating output by analogy. Heating to a designed inlet temperature below the bivalence temperature will be secured by an additional source.

10. Design of a heating system with a heat pump

A heating system with a heat pump must be designed by a qualified technical designer that suggests an optimal heating system solution for a specific heating system and integrates a heat pump in the system, considering the requirements formulated in this documentation and other PZP's designing data and information.

This documentation does not replace a design solution prepared for specific projects!

The connection of a bivalent source other than an electro-boiler has to be agreed upon with the heat pump's manufacturer.

11. TCLM KOMPLET heat pump assembly and commissioning

The heat pump should be placed in a suitable interior – the machine room of the heating equipment. Its location is selected so that access is secured for the installation of air pipelines, for the connection of the outer secondary circulation circuit, for the connection of electric wiring, and for the maintenance (servicing) of the mechanical and electric part. The side witch switchboard and entire front wall of the heat pump must remain free and accessible (at least 80 cm in front of it).

The supply of the outside air to and the removal of the cooled air from the heat pump is secured through the air pipelines, for instance, by flexible insulated piping. The inlet and the outlet at the limit of the premises shall be provided with a bushing with a grill that will prevent the penetration of insects. The inlet and the outlet should be placed on the different sides (walls) of the building in which the heat pump is placed in order to prevent air current short-circuit between the inlet and the outlet. Short circuit would cause a decrease in the heat pump's output. If the inlet and the outlet cannot be placed on different sides and only one side (wall) can be used, a minimal distance of 2.5 m must be kept between the inlet and the outlet and it is further recommended to situate them at different heights. The air outlet can be installed in the roof, for instance, by means of a chimney outlet covered with a rooflet.

Bushings are installed in the wall to allow for the installation of air pipelines through the perimeter wall; on the outside, the bushings are fitted with protective grills. The bushing is attached by means of two screws and plastic expandable sockets. The bushings, like the heat pump, are equipped with doubled round collars to connect thermally insulated flexible piping. A round hole with a diameter of 430 or 480 mm must be prepared in the wall before the installation of the bushing (see the dimensional sketch).

The discharge opening of the tub located in the lower part of the heat pump should be fitted with a siphon and waste piping is introduced into a waste trap – read chapter 6. If the waste piping is led through areas with the occurrence of temperatures lower than 0 °C, it is necessary to protect the piping properly from getting frozen, for instance, by means of an electrical heating cable.

Before commissioning the heat pump, its accumulation tank must be filled with nonfreezing liquid. The tank is filled through a filling opening that can be accessed after removing the front upper cover. The cover is located in the left front part of the tank and is covered with a protective sleeve that is to be refitted once the tank has been filled. Approximately 40 liters of liquid are needed when filling the tank. The solidification point of the nonfreezing liquid must be at least – 30 °C. The tank is filled so that the liquid level reaches no higher than 1 cm below the upper wall of the tank.

The installation of the secondary circuit and the integration of the heat pump in the heating system must comply with all requirements specified in this documentation (specified in the highlighted paragraph).

Once the air pipelines and the waste piping have been installed, the accumulation tank has been filled with nonfreezing liquid, the outer secondary circulation distribution system and the entire heating system have been installed, and the controlling and power wiring has been connected, the heat pump can be activated and commissioned.

The activation and commissioning of the heat pump can be carried out only by a company authorized by the manufacturer.

The activation and commissioning proceed in these steps:

- Check the phasing of the feed, and the adjustment of line protecting devices and of the regulator;
- Check the operation of the heat pump's blocking elements;
- The flow rate of the heat pump heating medium is adjusted according to this documentation and a respective design;
- The operation of the heating system and of the heat pump is tested;
- In a bivalent system, an assigned electro-boiler is commissioned and its function is tested along with the blocking. Cooperation with the heat pump and with heating system is tested as well;
- The initial inspection of the wiring is carried out.

Once these steps have been completed, the heat pump can be introduced in permanent operation.

12. Data for inquiry (order)

An inquiry for a TCLM KOMPLET heat pump (order) must indicate the following information:

- Heat pump type marking according to this informative material
- Required number of controlled heating circuits; maximum number is 6 (standard manufacturing – 2 heating circuits)
- Requirement for non-standard manufacturing, if any (the manufacturing of the heat pump without an electro-boiler or a distribution three-way valve)
- Requirement for the different length of the supplied flexible insulated piping – indicate necessary length (standard length 10 m)

13. Type marking

TCLM heat pumps are marked as follows:

TCLM KOMPLET	5.3 / P / EK 3+3+4,5	Electro-boiler heaters' output breakdown
		Heat pump manufacturing P - 'right' version L - 'left' version
		Heat pump rated capacity according to the table
		Heat pump type marking

14. Working conditions

TCLM KOMPLET heat pumps can be used:

- As a heat source for the heating of family houses;
- Other applications are subject to an agreement with the manufacturer.

TCLM KOMPLET heat pumps can be operated as follows:

- In stationary installations in a place that is protected from weather conditions
- In climatic areas CT, WT, WDr – according to IEC 721-2-1 (under the conditions of 'Environment Classification')
- In environment that is classified as standard according to IEC 364-3

Environment classification:

- During operation class 3K4/3Z9/3B1/3C2/3S2/3M2 – according to EN 60721-3-3
- During storage class 1K3/1B1/1C2/1S3/1M2 – according to EN 60721-3-1
- During transport class 2K2/2B1/2C2/2S1/2M2 – according to EN 60721-3-2

The heat pump must not be placed or operated in an environment with the risk of the explosion of flammable gases and vapors BE3N2 according to IEC 364-3.

The heat pump must be removed from operation (by turning off the main lead) before starting work that might result in the changes of the environment (such as gluing, varnishing, etc.) in the room in which the heat pump is installed.

Requirements for the location of the heat pump

As per EN 378-1, if the heat pump is located in a special machine room it is not subject to any restrictions regarding the volume of the space where the heat pump is placed with regard to the amount of a cooling agent. In the opposite case, the volume of the space where the heat pump is placed must meet the following rule: the volume of the space in [m³] is larger than the filling of the cooling agent in [kg] divided by 0.48 (critical concentration in [kg/m³]).

Electrical equipment and its technical parameters:

- Rated feeding voltage 3 x 400/230 V ± 10 %
- Current type and frequency alternating, 50 Hz ± 1 %
- Maximal power input see the table
- Mains characteristics TN-C, TN-S – according to IEC 364-4-41
- Protection category I – according to EN 60335-1
- Degree of coverage protection IP43 – according to EN 60529 (applies to prescribed assembly and installation)

Limit values of the temperature of the outside air:

- Maximal air temperature + 40 °C
- Minimal air temperature - 18 °C

Secondary circuit working substance (heating medium):

- Priority is given to non-corrosive water free of mechanical impurities
- Other substance can be used after an agreement with the manufacturer

The active part of the secondary circuit:

The active part of the secondary circuit:

- Maximum working overpressure 600 kPa
- Minimal overpressure 25 kPa
- Maximum working temperature 55 °C

Mains supply:

- Fixed; information about rating specifications and protection is provided in chapter 8.2 of this designing document.

15. Scope of delivery

The TCLM heat pump is delivered as completely assembled and tested equipment accompanied with a 'Quality and Completeness Certificate', however without takeover. The heat pump is supplied including the filling of a cooling agent.

Following the proper installation of the heat pump, after its connection to the outer distribution lines of the secondary circuit, after its connection to the mains supply and after the connection of the other components of the heating system, the heat pump can be activated and commissioned – read chapter 11.

The TCLM KOMPLET heat pump is delivered along with the following:

- Condensate discharge outlet
- Nonfreezing liquid – 40 liters
- Primary circuit accessories (flexible insulated piping – 10 m, bushing with a grill – 2 pieces, tightening clips – 4 pcs)
- Replacement thermal probes - 2 pieces
- Technical accompanying documentation
- Tables with data according to EN 378-2

16. Technical Documentation (TPD)

Technical documentation includes:

Assembly and Commissioning Instructions
 Equipment Operation and Maintenance Manual
 'TCLM KOMPLET heat pumps designing data and information'
 Table of applied components
 Cooling circuit and wiring connection schemes
 Electrical equipment initial inspection report
 Certificate by a State Testing Laboratory in Brno
 Quality and Completeness Certificate, warranty certificate; maintenance service form

17. Applied components

Hermetic compressors	Copeland (Germany)
(Plate) Heat exchangers	Alfa Laval (Sweden)
(Tubular) Heat exchangers	RTV (Slovakia)
Axial ventilators	ebm (SRN)
Regulation devices	Alco (SRN), PZP (Czech Republic)

The manufacturer reserves the right to modify this information depending on the further improvements of the TCLM KOMPLET heat pumps.

TCLM KOMPLET heat pumps and their technical parameters

Type size	TCLM KOMPLET		5.3	7.1
Data		Size		
Energetic parameters	Heat pump			
	- inlet water temperature	40,0 °C		
	- at ambient temperature	12,0 °C		
	- outlet water temperature	46,4 °C		
	- heating output	kW	6,83	9,14
	- input	kW	1,98	2,69
	- performance factor	-	3,45	3,40
	Rated parameters			
	- at ambient temperature	0,0 °C		
	- outlet water temperature	45,0 °C		
	- heating output	kW	5,30	7,10
	- input	kW	1,78	2,42
	- performance factor	-	2,97	2,93
- at ambient temperature	-15,0 °C			
- outlet water temperature	43,4 °C			
- heating output	kW	3,63	4,85	
- input	kW	1,53	2,08	
- performance factor	-	2,37	2,33	
Electro-boiler				
- standard installed output	kW	6,00	9,00	
- maximal possible output	kW	13,50	13,50	
Circuit parameters	Primary circuit			
	- flow rate	m ³ /h	1750	2250
	- available external static pressure	Pa	40	40
	Secondary circuit			
- flow rate	l/min	15,20	20,36	
Other parameters	Compressor			
	- compressor type	-	ZS 15 K4E	ZS 21 K4E
	- maximal operational current	A	4,5	6,3
	Ventilator			
	- ventilator type	-	S4D 350	S4D 400
	- input	kW	0,12	0,14
- Total heat pump input	kW	15,70	16,40	
Size and weight	- width	mm	870	870
	- depth	mm	775	775
	- height	mm	1710	1860
	- weight	kg	250	260
	- primary circuit connection	mm	∅ 353	∅ 403
	- secondary circuit connection	mm	Cu pipe ∅ 28x1	
	- condensate discharge outlet	mm	Cu pipe ∅ 22x1	

Note: With an inlet temperature of 45 (35) °C, the following applies:
 - heating output is reduced (increased) by about 5 %
 - heating output is reduced (increased) by about 10 %

The 'Total heat pump input' data apply to a heat pump with an installed electro-boiler with an output of 13.50 kW.

TCLM KOMPLET heat pumps and their technical parameters (additional data)

Type size	TCLM Komplet		5.3	7.1
Data		Unit		
Energetic parameters	A15/W50²⁾			
	- heating output	kW	7,1	9,5
	- effective input	kW	2,2	3,0
	- performance factor (COP)	-	3,2	3,2
	A7/W50²⁾			
	- heating output	kW	6,0	8,1
	- effective input	kW	2,1	2,8
	- performance factor (COP)	-	2,9	2,9
	A2/W50²⁾			
	- heating output	kW	5,4	7,2
	- effective input	kW	2,0	2,7
	- performance factor (COP)	-	2,7	2,6
	A-7/W50²⁾			
	- heating output	kW	4,3	5,8
	- effective input	kW	1,9	2,6
	- performance factor (COP)	-	2,3	2,3
	A7/W35²⁾			
	- heating output	kW	6,5	8,7
	- effective input	kW	1,7	2,3
	- performance factor (COP)	-	3,9	3,9
	A2/W35²⁾			
- heating output	kW	5,8	7,8	
- effective input	kW	1,6	2,2	
- performance factor (COP)	-	3,6	3,6	

1) Energetic parameters of heat pumps are given according to standards EN 255.

2) For example A2/W50 means: The temperature of primary source of energy (air) +2°C, the temperature of water at the outlet of heat pump +50°C.

Dimensional sketches of TCMM KOMPLET 5.3 (7.1) heat pumps

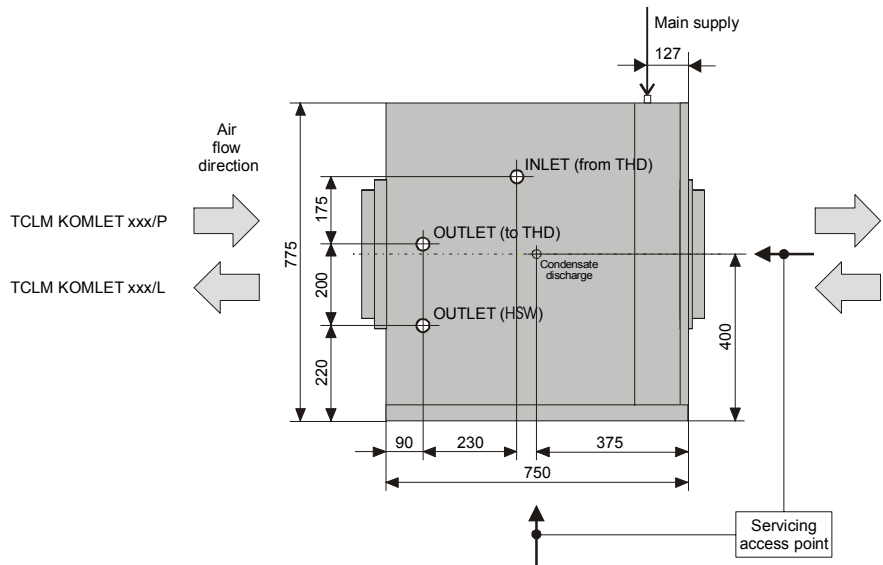
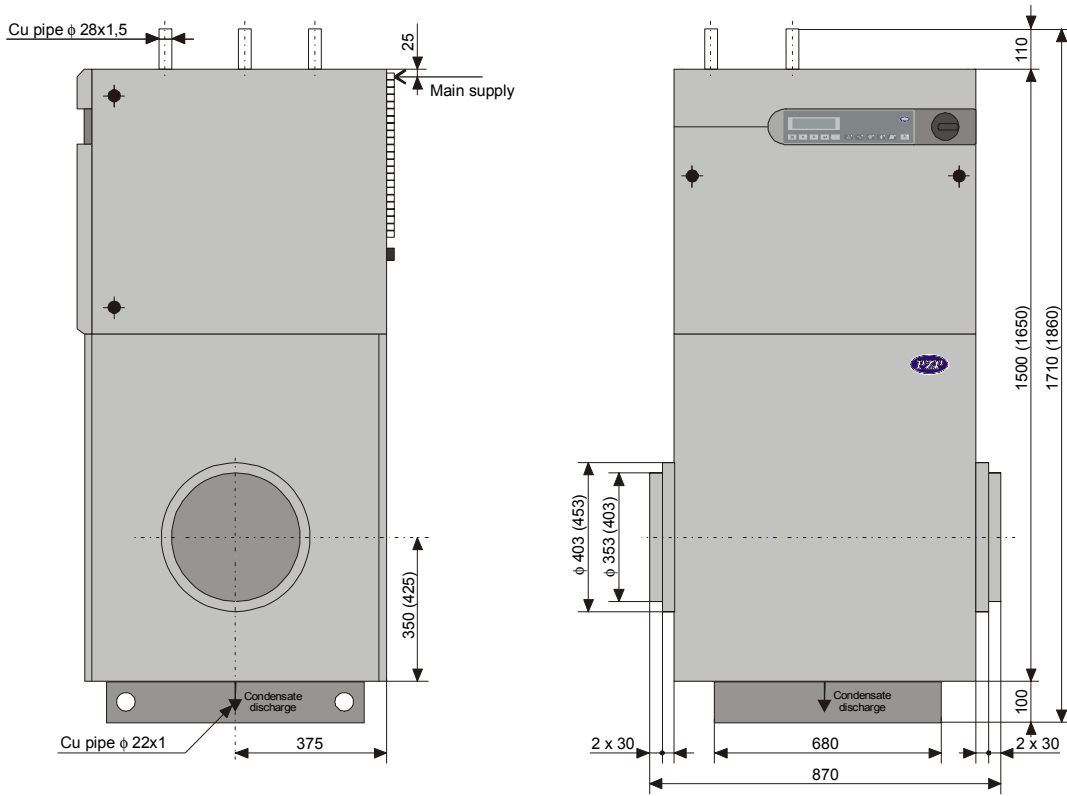

Bushing with grill

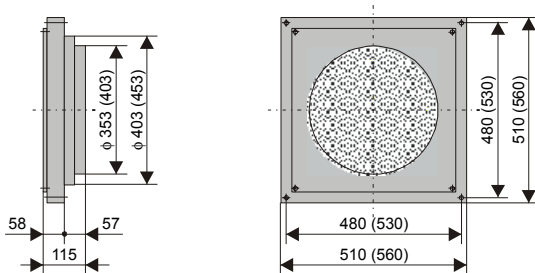

Detailed mounting

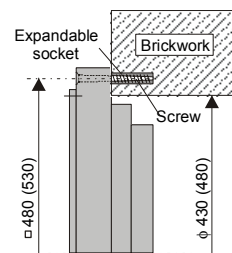

Principle of the connection of TCLM KOMPLET heat pumps

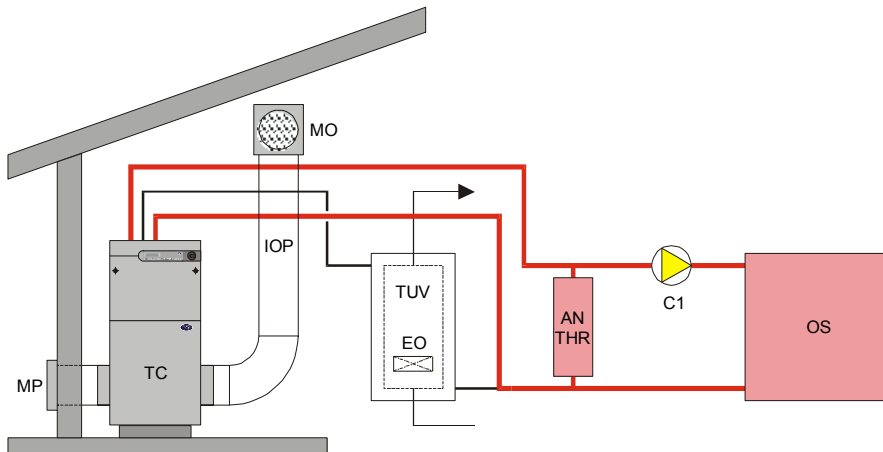

Picture 1a HSW preheating in a double-wall boiler during a heating delay period. The 'heating' working mode.

Explanation:

- AN - Accumulation tank
- C1 - Circular pump for heating system
- EO - Electrical heating
- IOP - Insulated flexible piping
- MO - Air removal grill
- MP - Air supply grill
- OS - Heating system
- TC - TCLM KOMPLET heat pump
- THR - Thermohydraulic distributor (THD)
- TUV - Hot service water

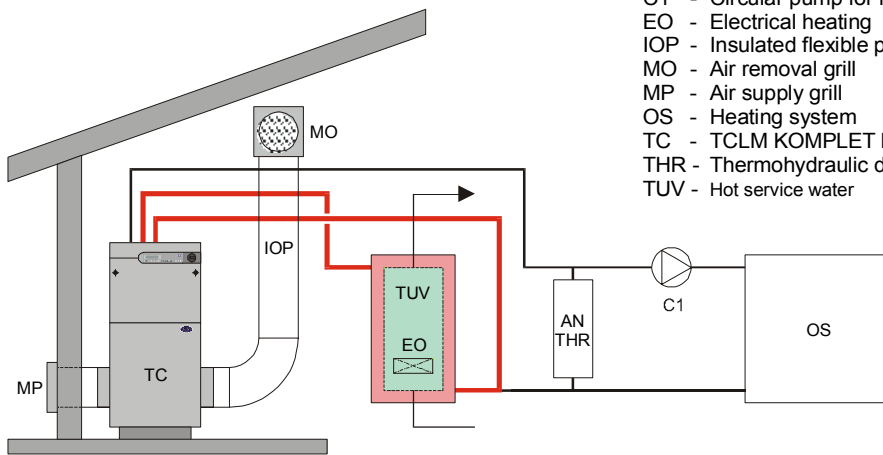

Picture 1b HSW preheating in a double-wall boiler during a heating delay period. The 'HSW preheating' working mode.

Explanation:

- C2 - Circular pump for KZ
- KZ - Standard (existing) source
- SVS - Existing heating system

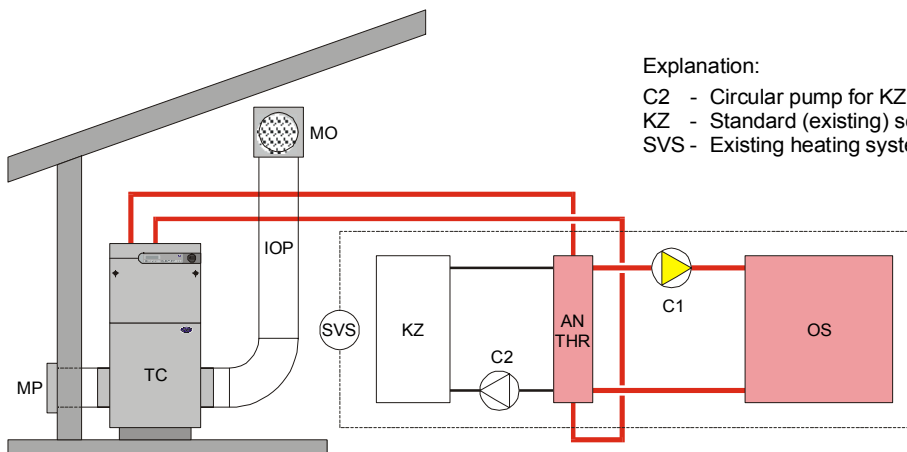

Picture 2 Connection within an existing heating system with an automatically operated, standard heat source such as earth gas boiler, liquid propane, or ecological heating oil.

Mains supply sizing

Admissible synchronous operation of the heat pump and of the electro-boiler + (HSW)

Combination of HEAT PUMP + ELECTRO-BOILER + (HSW) Combination of HEAT PUMP + GAS BOILER Heat pump rated output	TCLM KOMPLET feed fusing [A]					Heat pump + gas boiler
	10	16	20	25	32	
	Max. admissible input of ELECTRO-BOILER + (HSW) [kW]					
Without heat pump	6.5	10.4	13.0	16.3	20.8	
5.3	4.6	8.5	11.1	14.4	18.9	10
7.1	3.9	7.8	10.4	13.7	18.2	10

Explanation: TC – heat pump
 EK – electro-boiler
 PK – gas boiler
 (HSW) - electrical heating of hot service water (it is counted in only if it is a three-phase type)

Max. admissible input of electro-boiler + (HSW)

- i.e. while the heat pump is operating
- i.e. if working below a bivalence temperature no greater than 0 °C
- it is determined without a reserve from a conversion constant of 1 A = 0.65 kW

Recommended circuit breakers and cables

Feed line protection	Mains supply circuit breaker	Mans supply cable - CYKY
10 A	C 10 A	5C x 2,5
16 A	C 16 A	5C x 2,5
20 A	C 20 A	5C x 2,5
25 A	C 25 A	5C x 4
32 A	C 32 A	5C x 6

Mains supply sizing tables do not replace an electrical wiring scheme!