

# Biomass Range

Wood Chip & Pellet Boilers



A practical guide to choices of fuel, storage, fuel transport and biomass boiler installation up to 2000 kW.

OUTPUTS: 12.5-2000 kW  
Larger outputs available on request.



**remeha**  
creating energy solutions

**GILLES**   
BIOMASS HEATING

# Remeha - Providing the most effective boiler technology

Remeha is part of the De Dietrich Remeha Group - one of the top five boiler manufacturers in the European commercial and domestic heating market. The Remeha brand is renowned for quality, reliability and efficiency. We are committed to increasing the already high performance standards of our boilers through an ongoing programme of technological innovation. De Dietrich Remeha Group and Baxi Group have announced the creation of BDR Thermea, a new world class company in innovative climate and hot water solutions and services. The complementary geographic profile of De Dietrich Remeha Group and Baxi Group will put the new group in a leading position in all Western European Countries.

With more than 35 years experience in the development and production of condensing boilers, Remeha is at the forefront of this field. We are also a leading supplier of biomass boilers and offer a wide range of

commercial atmospheric and forced draught boilers. In addition, Remeha's range of domestic boilers includes some of the lightest and most compact and efficient products on the market.

Global climate change is one of the most pressing issues of our time and, in response to this, Remeha offers a pioneering carbon offsetting programme, in partnership with J.P. Morgan ClimateCare. Having offset the carbon emissions from its own UK operations, Remeha can provide the opportunity for its customers to do the same.

Carbon offsets can be arranged against the predicted carbon emissions for each new Remeha boiler so that a near neutral carbon balance is created. All funds donated for carbon offsets are used to finance carbon reducing projects in poorer countries.

For more information on Remeha products and the carbon offsetting programme, please call: 0118 978 3434.



# Climate change

Global climate change is the most pressing environmental challenge of our time and one of the major causes of climate change is emissions of carbon dioxide (CO<sub>2</sub>) from burning fossil fuels. One of the most important environmental benefits of using sustainably produced wood for energy in place of fossil fuels is its positive impact in moderating long-term global climate change.

Fossil fuel combustion takes carbon that was locked away underground (as crude oil, gas, or coal) millions of years ago and transfers that carbon to the atmosphere as new CO<sub>2</sub>. When wood is burned, on the other hand, it recycles carbon that was already in the natural carbon cycle, which is recaptured through sustainable forest growth. Consequently, the net long-term effect of burning wood fuel is that considerably less new CO<sub>2</sub> is added to the atmosphere, as long as the sources from which the wood came are sustainably managed.

Since wood burning uses a LZC fuel source and burning fossil fuels causes climate change, when wood replaces fossil fuelled heating the net impact should be that, over the long term, CO<sub>2</sub> levels in the atmosphere are reduced. If a fossil fuelled heating system is converted to wood, net CO<sub>2</sub> emissions for heating are reduced. For this reason we believe, heating with wood is one of the most powerful tools for an institution or community interested in meaningfully addressing climate change and renewable energy through its own energy use.

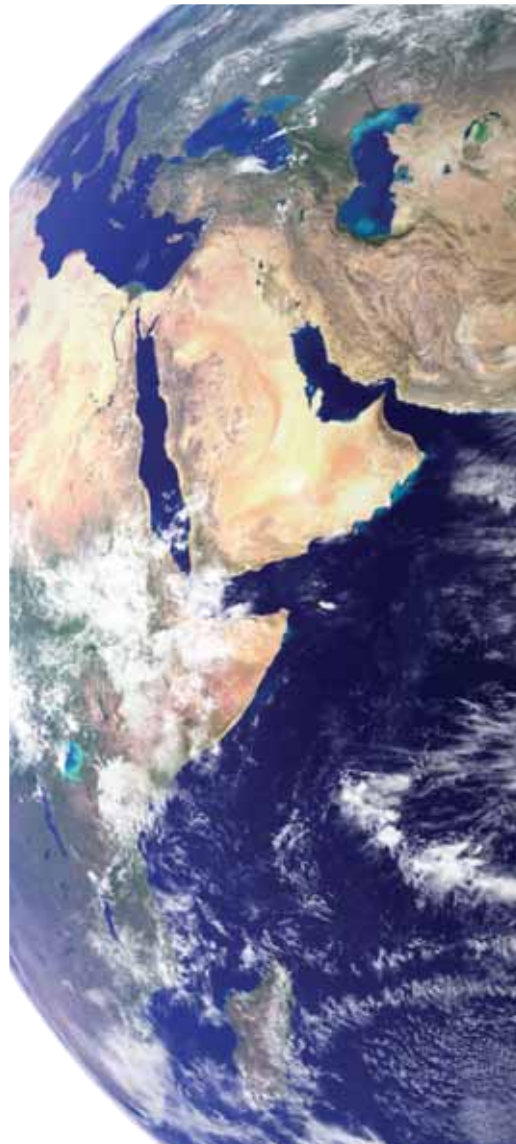

## Remeha-Gilles Biomass boiler

The most efficient way of getting heating equipment to run on low to zero carbon fuel (woodchip & pellet). When heat is required on demand, the Remeha-Gilles modulating fully controllable automatic Biomass boilers are the solution.

The boilers have an increased service life because of their modulating outputs which range from 12.5kW-2000kW (output up to 5000kW available subject to project circumstances-Contact Remeha).



# Fuel choices

This guide is to help the designer decide which wood fuel to choose and assumes that the choice to burn wood chips or pellets as a fuel has been made and that the different characteristics of the fuel need to be considered before making a final decision.

## Wood pellets vs wood chips

- Pellets flow freely whereas chips do not.
- Pellets are a more dense form of fuel than chips therefore take less storage space per kw/hr.
- Pellets are generally more expensive per kw/hr than chips.
- Chips are more environmentally friendly than pellets as they take less energy to create.
- A wood chip boiler can burn pellets whereas a pellet boiler can't burn chips.

## In brief summary

It can be seen that wood chips are more environmentally friendly but take up more storage space.

At the time of writing (Summer 2010) chips are about 60% of the cost per kw/hr of Natural Gas and pellets are about the same as Natural Gas, therefore chips do have the possibility of giving a payback as well. Pellets are about 50% the cost of Gas Oil per kw/hr.

But if fuel storage space, on site labour or a local supply of chips are unavailable, it is evident that pellets will give a significant carbon reduction over traditional heating fuels.

	Wood pellets	Wood chips	Natural gas	35 sec oil
Density kg/m <sup>3</sup> approx	650	200	-	-
Heat output kw hr/m <sup>3</sup> approx	3000	800	-	-
Emissions kg CO <sub>2</sub> /Mw hr	50-60	35-40	230	380

## Wood fuel storage

Consideration now needs to be given to the type of fuel store suitable for the different fuels as each has a different requirement. There is however one overriding consideration to bear in mind for both fuels: it is easier to move the heating system water than wood fuel, so try and keep the fuel store as close to the wood boiler as possible, the simpler the fuel route the better!!

## Wood pellet storage

As mentioned earlier pellets will free flow so they can be kept in a fuel store with a sloping floor to a central feed auger as shown below (A) - ideal slope 35 degrees or more.



The fuel can then be moved using augers (worm screws) to the boiler (B). Or feed another auger to take the fuel further using extra augers (C).

### Wood chips storage

As mentioned earlier, chips don't free flow so are not suitable for the sort of storage used for pellets. To move chips from the store to the transport system, a Sweep Auger needs to be used - see below.

In operation the auger, which is driven by an electric motor, transfers its drive into a gearbox underneath the circular disc which then makes the arms rotate and drag the fuel to the auger. The fuel is then transported to the boiler via the auger(s) like wood pellets.

Choose the largest diameter sweep collector that will fit between the fuel store walls to minimise fuel left around the edge.

Sweep collector operation undermines fuel causing it to fall inwards and then be fed into the feed auger - 1 motor drives sweep collector and feed auger.

The wood chip store should be as square as possible to minimise fuel left in the corners.

### Sweep Auger gathers and delivers wood chips from store

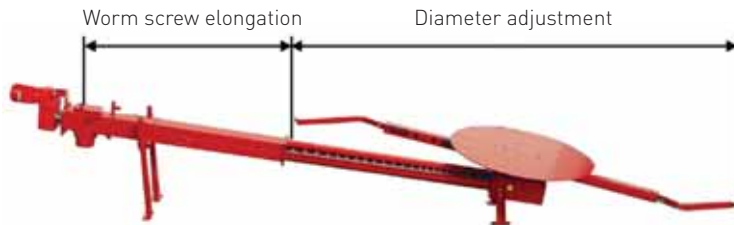

Above: As mentioned in 'Fuel Choices' wood chip stoking equipment is more robust than pellet equipment- here we have fully welded auger flights on a solid 50mm shaft.

# Pellet heating

## HPK-RA 12.5-150



### Pellet boiler HPK-RA

The high-performance boiler is produced as a stress-free welded construction. The heat insulated front door opens outwards. The cleaning of the boiler flue pass is performed fully automatically by means of a special drive via 6mm strong auger flights. The boiler is suitable for automatic combustion of pellets and also with no modification for log wood operation by an additional combustion chamber door and grate. Welded multiple-draught boiler in **thick-walled boiler plate St. 360 (6mm width)**. Horizontal heat exchanger in seamless drawn thick-walled boiler pipes.

70 mm width external insulation. Operational pressure max. 3 bar. Automatic ash discharge integrated in boiler base and rolling ash container. Suitable for combustion of pellets and industrial pellets. Ö-Norm M7135 / DIN plus / Class A1.

<b>HPK-RA</b>	<b>12.5</b>	<b>14.5</b>	<b>19.5</b>	<b>-</b>
Nominal Load	12.5	14.5	19.5	-
Length l (mm)	1165	1165	1165	-
Width b (mm)	620	620	620	-
Height h (mm)	1290	1290	1290	-
Weight (kg)	421	421	421	-
<b>HPK-RA</b>	<b>15</b>	<b>20</b>	<b>25</b>	<b>-</b>
Nominal Load	14.1	20	25	-
Length l (mm)	1165	1165	1165	-
Width b (mm)	620	620	620	-
Height h (mm)	1485	1485	1485	-
Weight (kg)	443	443	443	-
<b>HPK-RA</b>	<b>30</b>	<b>35</b>	<b>40</b>	<b>49</b>
Nominal Load	30	35	40	49
Length l (mm)	1430	1430	1430	1430
Width b (mm)	765	765	765	765
Height h (mm)	1445	1445	1445	1445
Weight (kg)	724	724	724	724
<b>HPK-RA</b>	<b>60</b>	<b>75</b>	<b>85</b>	<b>-</b>
Nominal Load	59.7	75	85	-
Length l (mm)	1540	1780	1780	-
Width b (mm)	935	935	935	-
Height h (mm)	1785	1785	1785	-
Weight (kg)	1330	1570	1570	-
<b>HPK-RA</b>	<b>100</b>	<b>120</b>	<b>145</b>	<b>150</b>
Nominal Load	100	120	145	153
Length l (mm)	2155	2155	2620	2620
Width b (mm)	935	935	935	935
Height h (mm)	1785	1785	1785	1785
Weight (kg)	1963	1963	2463	2463

Dimensions are without burner attached. Burner can only be side mounted up to 60kW, preferably rear mounted 75kW and above. From 100kW up its compulsory to have burner on rear of boiler.

# Pellet heating

## HPK-RA 12.5-150

Efficiency of all boilers on full and part load operation more than 90%



HPK-RA 15-60

TÜV certified



1. Cell wheel
2. Pellet burner in heat-resistant steel for HPK-RA 12.5 – 60 or ceramic for HPK-RA 75 – 150
3. Ash removal via ash agitator with special drive technology – ash compression resulting in long emptying intervals – rolling ash container
4. Combustion chamber door for log wood operation (no changeover required)
5. Horizontal pipe heat exchanger with automatic cleaning for maximum efficiency →90%
6. Ceramic-lined afterburning chamber with individually offset heat-resistant fire bricks
7. Flue gas fan for optimal ignition process and permanent negative pressure in the boiler
8. Lambda probe sensor for fuel detection and optimised, clean combustion process
9. Overheat protection
10. Welded multiple-draught boiler in 6 mm boiler plate
11. Shunt circuit with pump and mixing valve
12. Primary air modulating variable
13. Secondary air modulating variable



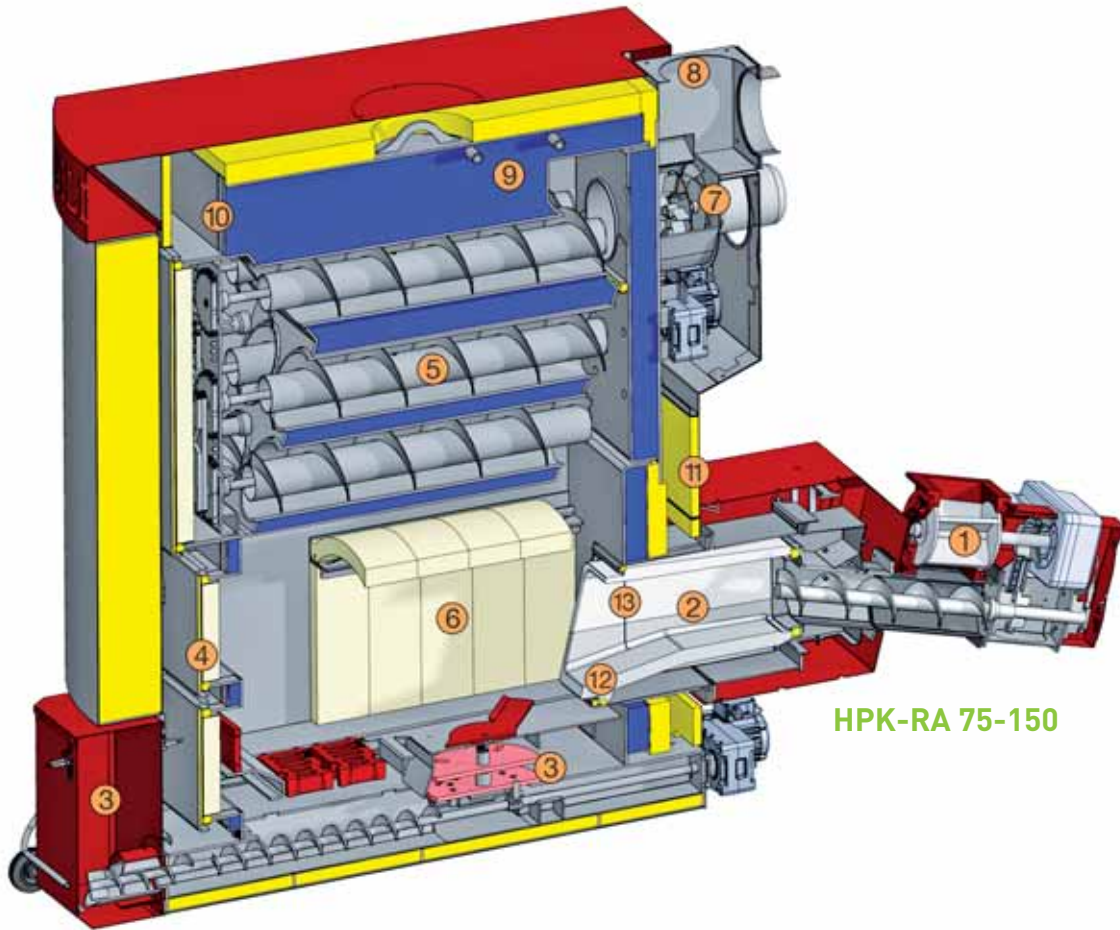

## SPECIAL FEATURES - Pellet burner



HPK-RA 12.5-60



HPK-RA 75-85



HPK-RA 100-150

### Combustion technology

High combustion temperatures guaranteed in all performance ranges and the best possible use of your fuel. Well-designed air guidance is a precondition for highest quality of combustion. Suitable for pellets and industrial pellets in accordance with Ö-Norm M7135 / DIN plus / Class A1.

# Pellet heating

## Boiler controls

### Boiler controls

- Simple operation from the control display
- Programmable logic controller (PLC)
- Automatic hot air ignition
- Modulating fuel feed
- Automatic reversing mechanism for cell wheel and augers from HPK-RA 49 up
- Optimised and clean combustion by lambda probe sensor
- Automatic, manual, buffer, DHW modes possible

Optional: Modem for SMS control  
(switch the heating on and off via mobile SMS)



## SPECIAL FEATURES

### Log wood heating without changeover!

You want to heat with log woods – no problem. Just put in wood – everything else is controlled completely automatically!



The ignition process by burning pellets takes as long as it takes for the deposited wood to burn well. The pellet stoking is then reduced to the minimum feed rate and only then activated by sensors after the log wood has combusted.

# Pellet heating

## Pellet burner

### Pellet burner

High combustion temperatures guaranteed in all performance ranges and the best possible use of your fuel. Well-designed air guidance is a precondition for highest quality of combustion. Years of experience, high-tech development, resistant materials guarantee clean combustion and long service life.

1. Cell Wheel
2. Ignition Unit
3. Combustion Chamber (In Heat-Resistant Steel/Ceramic)
4. Ash Agitator

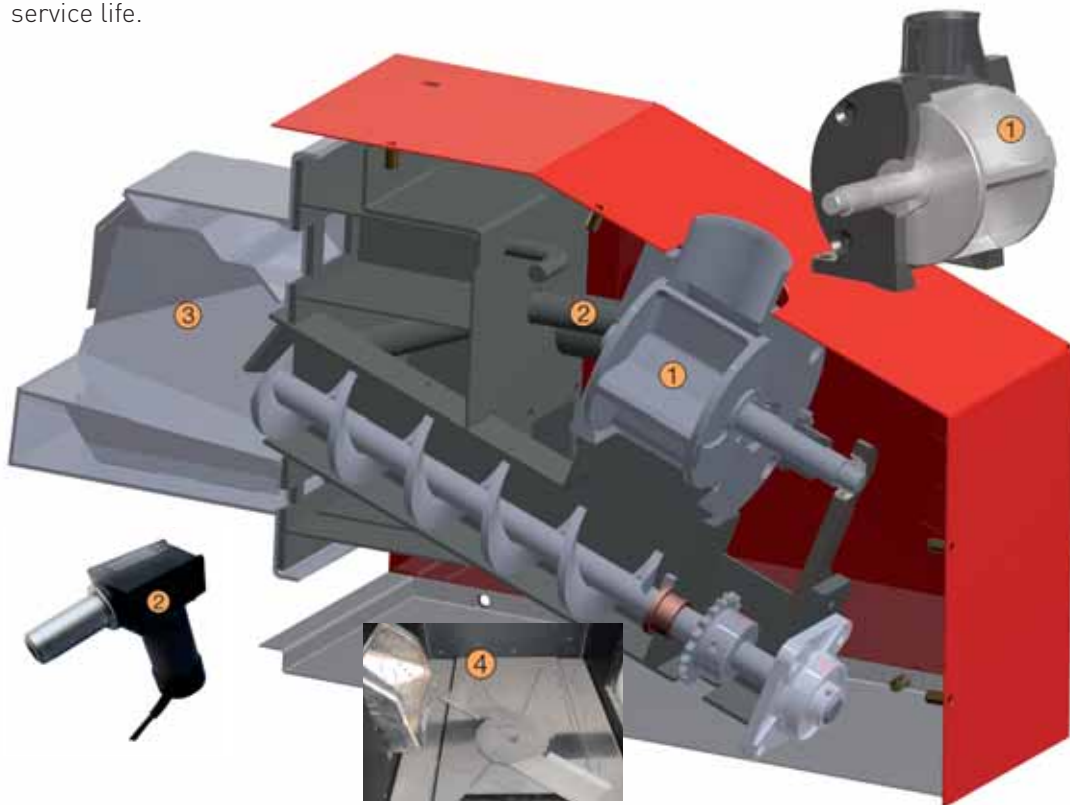

### Cell wheel

The multi-tested full-metal cell wheel reliably interrupts the boiler with the storage room and thus provides **100% protection against burnback**. The blades attached to the running wheel are slightly curved, which prevents noise generation and reduces compressive forces. From HPK-RA 75 these blades are running at an offset angle to the rotary axis to enhance the cutting action with a fixed cutting edge integrated in the stable and noise-damping cast enclosure. **Energy-saving 4-chamber system with low running surface.**

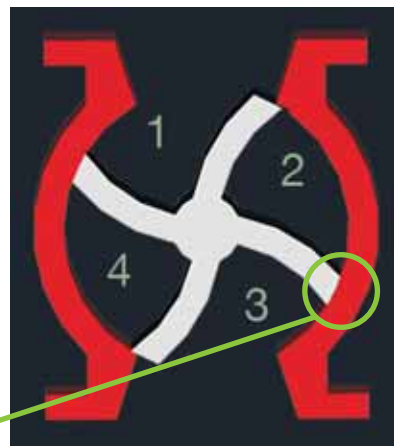

# Pellet heating

## Pellet storage

### Pellet box

If no pellet storage room is available or you do not want to adapt one, the Remeha-Gilles Pellet Box is the ideal and cost-effective solution. The flexible silo made of high performance synthetic fabric can store up to 9 tons of pellets in a compact manner.



	Volume	Qty stored	Height	Approx. dimensions
GPB 17	3.1 m <sup>3</sup> -5.2m <sup>3</sup>	2.1t - 3.2t	195 - 265 cm	170 x 170 cm
GPB 21	4.5 m <sup>3</sup> -7.5m <sup>3</sup>	2.8t - 4.7t	195 - 265 cm	210 x 210 cm
GPB 17/29	5.7 m <sup>3</sup> -8.3m <sup>3</sup>	3.6t - 5.4t	205 - 265 cm	170 x 290 cm
GPB 21/29	6.6 m <sup>3</sup> -10.2m <sup>3</sup>	3.8t - 6.1t	205 - 265 cm	210 x 290 cm
GPB 25	7.3 m <sup>3</sup> -11.0m <sup>3</sup>	4.8t - 6.7t	195 - 265 cm	250 x 250 cm
GPB 29	9.6 m <sup>3</sup> -14.1m <sup>3</sup>	6.0t - 9.0t	205 - 265 cm	290 x 290 cm

## SPECIAL FEATURES

### Transport auger

with progressive pitch (for gentle and easy transport of the pellets to the burner)



### Gear box protection coupling

prevents the auger and gear box from overload.

# Pellet heating

## Pellet transport systems



### Spiral auger

The flexible Remeha-Gilles conveyor is made of hardened steel and distinguishes itself by its particularly high tensile strength and spring force. This makes it possible to transport pellets – horizontally, vertically or in curves – up to 30 metres.



### Kinked auger

### Rising auger

### Standard auger

Pellets auger with gear motor, multiple bearings and support feet for stability. Auger channel for conveying the pellets with progressive pitch auger flights. After the system starts, the augers convey the pellets from the storage room towards the boiler into the cell wheel on the pellet burner. The special layout of the auger ensures smooth and trouble-free fuel transport.

# Pellet heating systems

## Planning examples

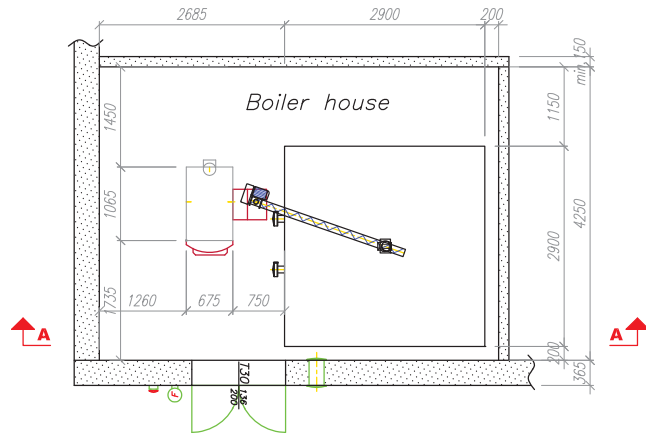

**HPK-RA 30**



**Alderman Peel  
(HPK-RA 145)**

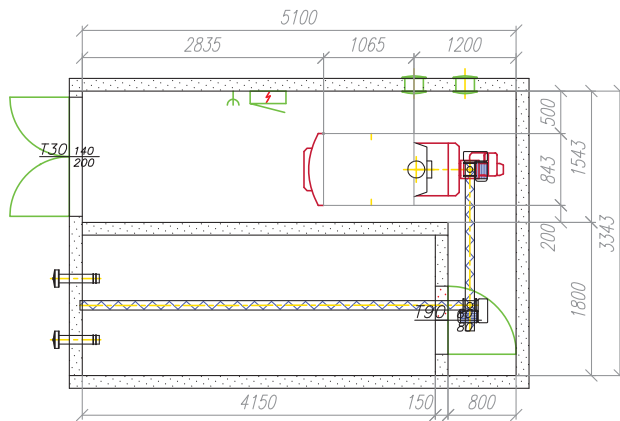

**HPK-RA 75**

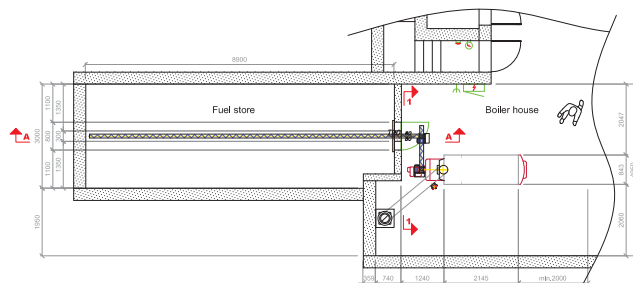

**HPK-RA 145**

# Pellet heating systems

## Case study

### Remeha-Gilles Biomass Boiler for ASDA's Green Store

Two 145kW biomass boilers, supplied by Remeha and manufactured by Gilles Austria, are playing their part in ensuring that ASDA's recently built store in Bootle is the most eco-friendly supermarket in the UK.

When ASDA invested £27 million in the construction of its new store at Bootle, sensitivity to the environment was high on the list of priorities.

Alongside ASDA's determination to achieve zero waste to landfill by the end of 2010, the Bootle store incorporates a variety of innovative technologies, reducing energy use by 40 per cent and cutting carbon emissions by a staggering 50 per cent in comparison to a standard new build supermarket.

Modulating, fully controllable and automatic, Remeha biomass boilers can be fully integrated with conventional boilers. In Bootle, the biomass boilers, fed by wood pellets, are used alongside a ground source heat pump and heat reclaim system.

High temperature operation and the length of time the gases remain in the biomass furnace guarantee clean combustion, further contributing to the excellent environmental standard set by the new ASDA store.



# Wood chip heating

## HPK-RA 15-150



### Wood chip boiler HPK-RA

The high-performance boiler is produced as a stressfree welded construction. The heat insulated front door opens outwards. The cleaning of the boiler is performed fully automatically by means of a special drive via 6mm strong auger flights. The gasification combustion chamber built on a direct pass principle is fitted with a variable, ceramic (replaceable) radiator roof cladding. High combustion temperatures and a long furnace duration of the gases is the guarantee for a clean burning process. Welded multiple-draught boiler in **thick-walled boiler plate St. 360 (6mm width)**.

Horizontal heat exchanger in seamless drawn thickwalled boiler pipes. 70 mm thick external insulation. Operational pressure max. 3 bar. Automatic ash discharge integrated in boiler base and rolling ash container. Suitable for the automated burning of wood chips up to G50, W30 and Ö-NORM M7133, pellets Ö-Norm M7135 / DIN plus / Class A1, industrial pellets and briquettes.



<b>HPK-RA</b>	<b>15</b>	<b>20</b>	<b>25</b>	<b>-</b>
Nominal Load	15	20	25	-
Length l (mm)	1165	1165	1165	-
Width b (mm)	620	620	620	-
Height h (mm)	1485	1485	1485	-
Weight (kg)	443	443	443	-
<b>HPK-RA</b>	<b>30</b>	<b>35</b>	<b>40</b>	<b>49</b>
Nominal Load	30	35	40	49
Length l (mm)	1430	1430	1430	1430
Width b (mm)	765	765	765	765
Height h (mm)	1445	1445	1445	1445
Weight (kg)	724	724	724	724
<b>HPK-RA</b>	<b>60</b>	<b>75</b>	<b>85</b>	<b>-</b>
Nominal Load	60	75	85	-
Length l (mm)	1540	1780	1780	-
Width b (mm)	935	935	935	-
Height h (mm)	1785	1785	1785	-
Weight (kg)	1330	1570	1570	-
<b>HPK-RA</b>	<b>100</b>	<b>120</b>	<b>145</b>	<b>150</b>
Nominal Load	100	120	145	150
Length l (mm)	2155	2155	2620	2620
Width b (mm)	935	935	935	935
Height h (mm)	1785	1785	1785	1785
Weight (kg)	1963	1963	2463	2463

Dimensions are without burner attached. Burner can only be side mounted up to 25kW. Preferably rear mounted 30kW and above. Side ways possible 30kW-85kW. From 100kW up its compulsory to have burner on rear of boiler.

# Wood chip heating

## HPK-RA 15-150

Efficiency of all boilers on full and part load operation more than 90%

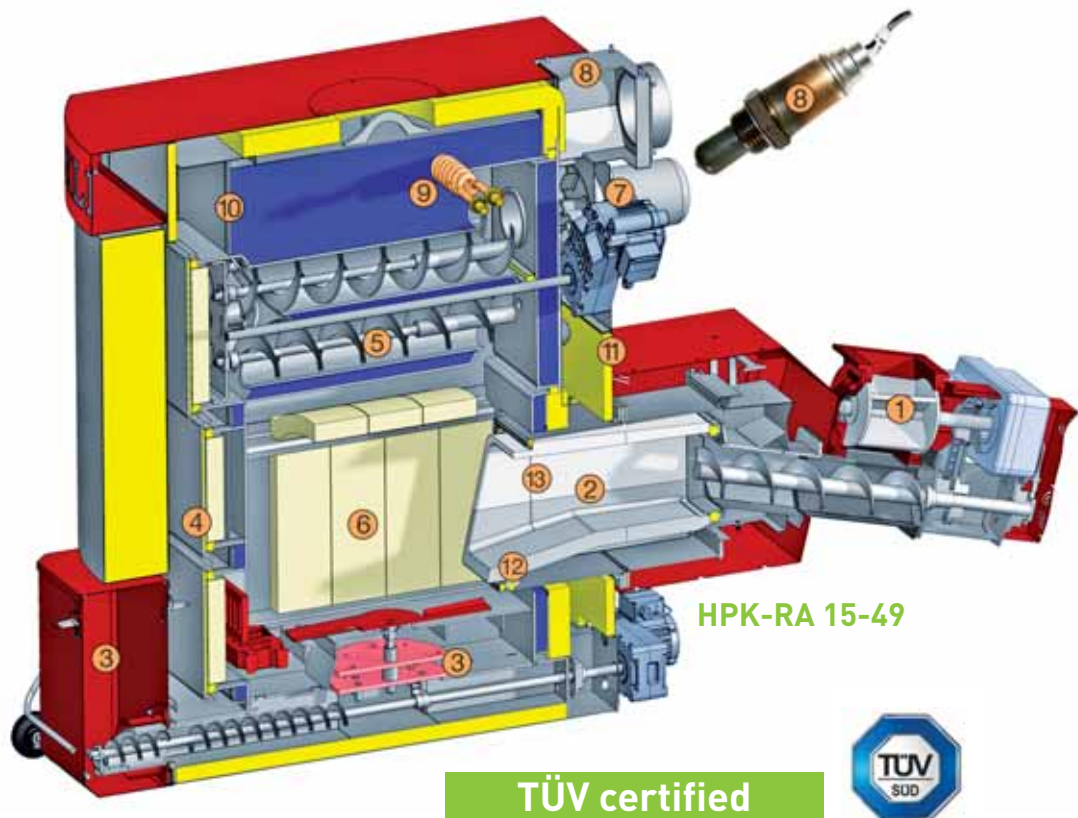

1. Cell wheel
2. Combustion chamber in high-quality heat-resistant ceramic or heat-resistant steel
3. Ash removal via ash agitator with special drive technology – ash compression resulting in long emptying intervals – rolling ash container
4. Combustion chamber door for log wood operation (no changeover required)
5. Horizontal pipe heat exchanger with automatic cleaning for maximum efficiency →90%
6. Ceramic-lined afterburning chamber with individually offset heat-resistant fire bricks
7. Flue gas fan for optimal ignition process and permanent negative pressure in the boiler
8. Lambda probe sensor for fuel detection and optimised, clean combustion process
9. Overheat protection
10. Welded multiple-draught boiler in 6 mm boiler plate
11. Shunt circuit with pump and mixing valve
12. Primary air modulating variable
13. Secondary air modulating variable

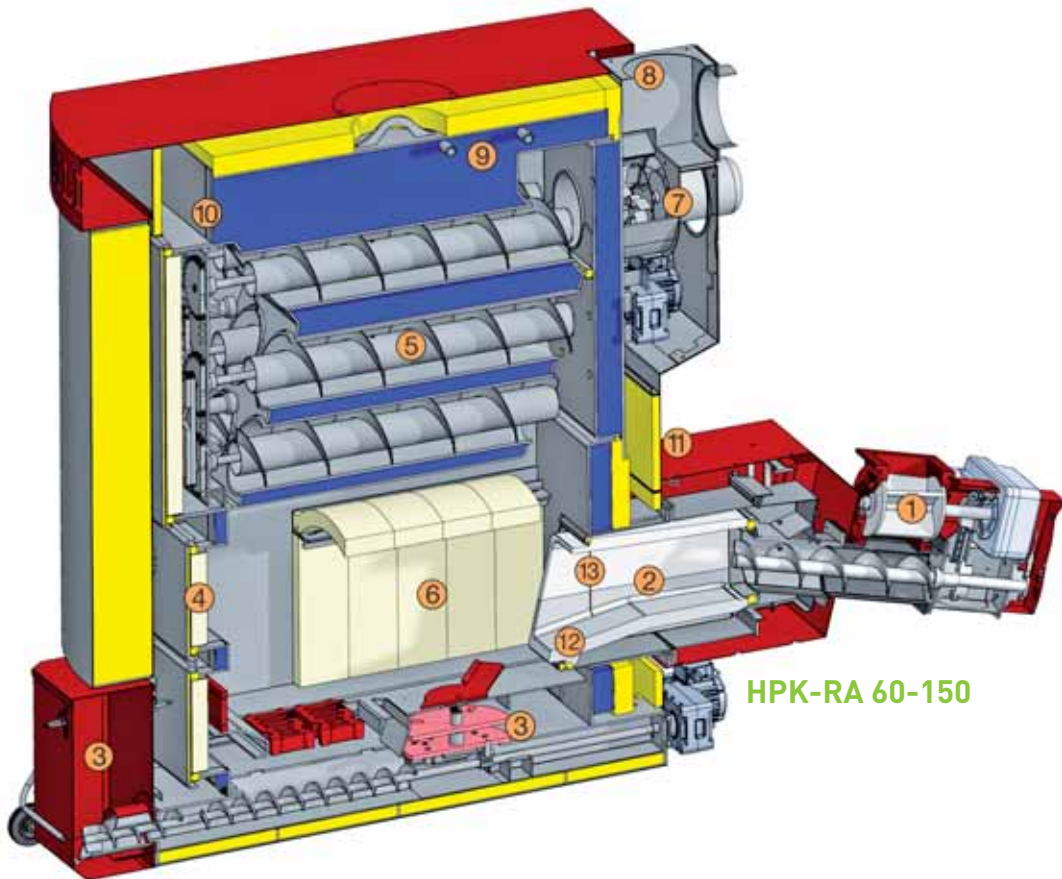

HPK-RA 60-150

## SPECIAL FEATURES - Ceramic burner



HPK-RA 30-85



HPK-RA 100-150

### Combustion technology

High combustion temperatures guaranteed in all performance ranges and the best possible use of your fuel. Well-designed air guidance is a precondition for highest quality of combustion. Suitable for sawdust, shavings, wood chips up to G50 (depending on the transport system), W30 acc. Ö-NORM M7133 timber briquettes and pellets acc. to Ö-Norm M7135 / DIN plus / Class A1 and many other materials on request.

# Wood chip heating

## Boiler controls

### Boiler controls

- Simple operation from the control display
- Programmable logic controller (PLC)
- Automatic hot air ignition
- Suitable for connection to BMS
- Modulating fuel feed
- Automatic reversing mechanism for cell wheel and augers
- Optimised and clean combustion by lambda probe sensor
- Automatic, manual, buffer, DHW modes possible

Optional: Modem for SMS control (switch the heating on and off via mobile SMS)

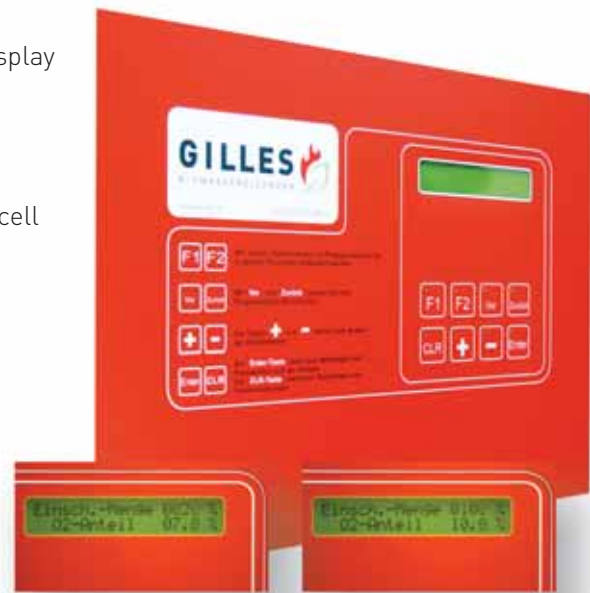

## SPECIAL FEATURES - Cell wheel

**100% protection against burn-back! Proven on thousands installations**



The multi-tested full-metal cell wheel reliably interrupts the boiler with the storage room and thus provides **100% protection against burnback**. The blades are attached to the running wheel at an offset angle to the rotary axis to enhance the cutting action. In addition, the blades are slightly curved, which prevents noise generation and reduces compressive forces. A fixed cutting edge is integrated in the stable and noise-damping cast enclosure to reduce the size of longer pieces of material. **Energy-saving 4-chamber system with low running surface.**

# Wood chip heating

## Wood chip auger and stoker

1. Spur gear motor (maintenance free due to oil immersed helical gears)
2. Connection point sprinkle valve
3. Ripping hook
4. Start-up relief by vibration cushioning
5. Ignition unit
6. Ceramic combustion chamber
7. Auger channel
8. Transport auger
9. Cell wheel

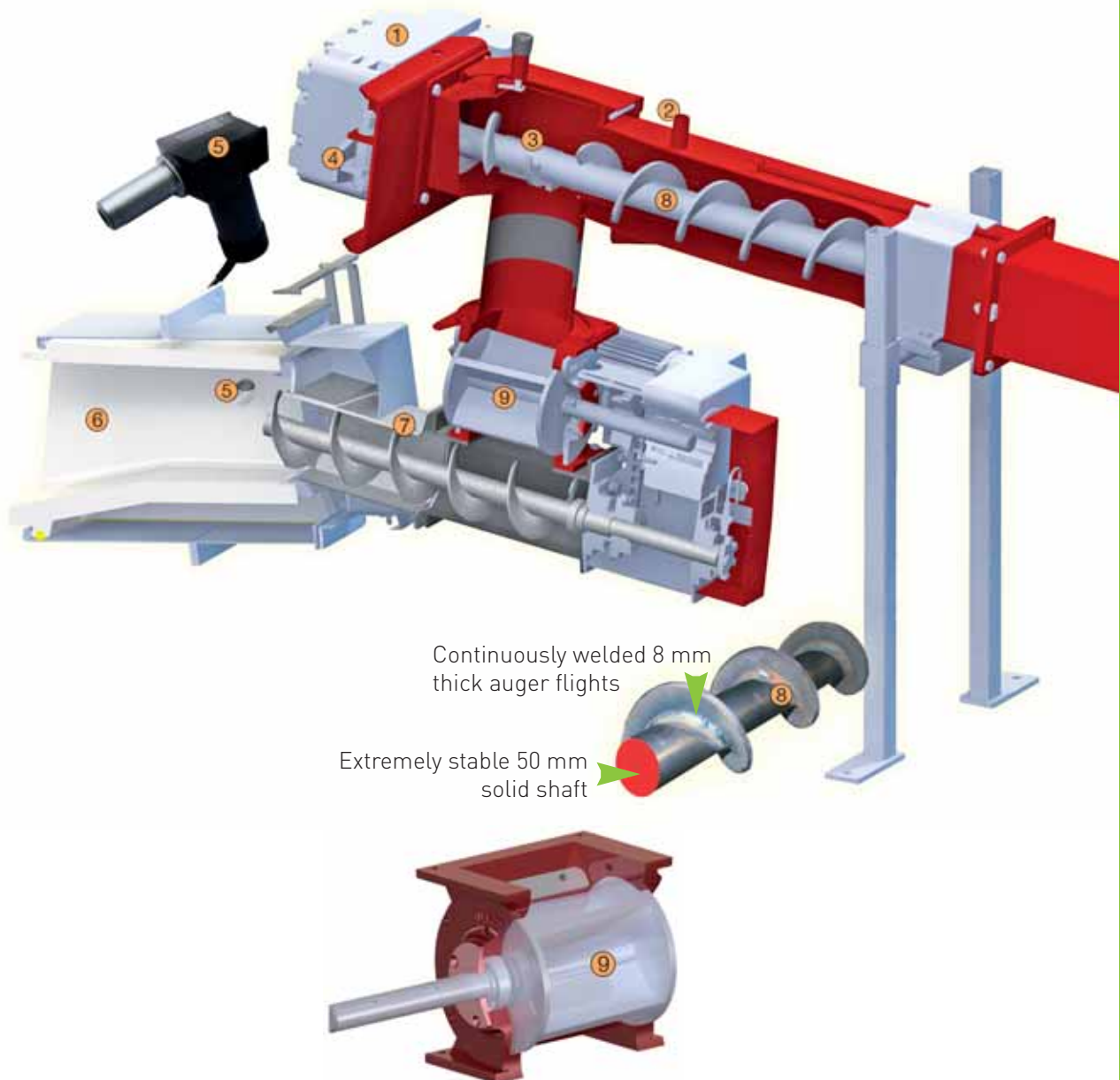

# Wood chip heating

## Wood chip transport systems

### Sprung sweep collector

Suitable for wood chips up to max. G30, W30 acc. to Ö-NORM M7133 for boilers up to HPK-RA 60



### Wood chip transport system - standard hinged arm sweep collector up to 240 kW

The main components are the spur gears used specifically by Remeha-Gilles. They have a torque of 5000 Nm and special seals that effectively and continuously prevent the penetration of dust and cuttings.

The robust design of the double-arm telescopic collector is also unmatched. This technology used by Remeha-Gilles is the first to allow safe, fully automatic and convenient wood combustion.

- 2 massive hinged arms make working in a small space radius possible
- Incl. pressure disc, gear motor and pre-tensioning device
- Up to 6 m diameter
- Max. fuel depth for wood chips: 8 m
- Max. fuel depth for pellets and wood briquettes: 2.5 m
- 50 mm solid auger shaft
- Continuously welded 8 mm progressive pitch auger flights
- Large dimension auger channel
- Wood chips up to G50, industrial wood chips, briquettes, pellets, sawdust

## SPECIAL FEATURES

### Ripping hook

Prevents blockages in that larger wood chips are automatically pushed down to then be cut in the cell wheel.



### Transport auger

with continuously welded 8 mm auger flights and progressive pitch (prevents blockages)



1. Drive motor with oil immersed helical gears and start-up relief by vibration cushioning
2. Robust auger with progressive flights suitable for wood chips up to G50
3. Double hinged arm system for optimal clearing of the wood chip storage room
4. Ripping hook
5. The spur gear box with shaft lip seal



# Wood chip heating

## Planning examples

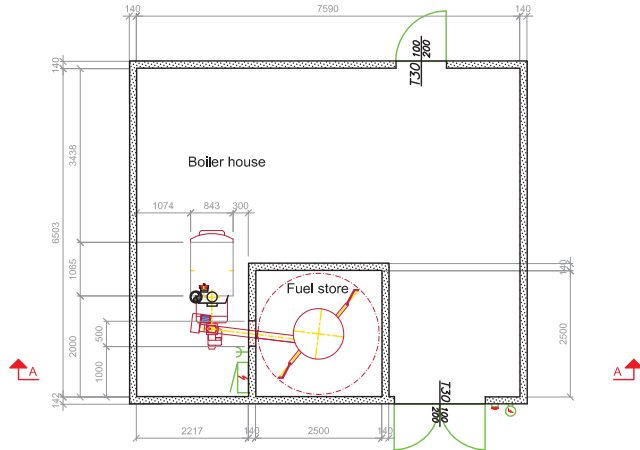

HPK-RA 60



Llandudno Junction Office  
(2 x 150 HPK-RA)

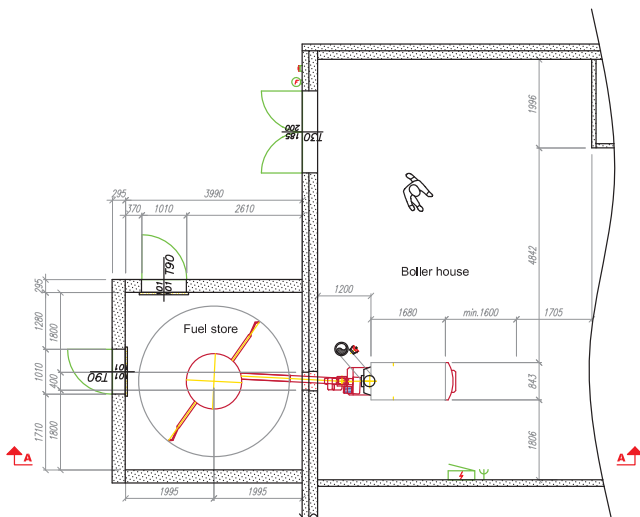

HPK-RA 100

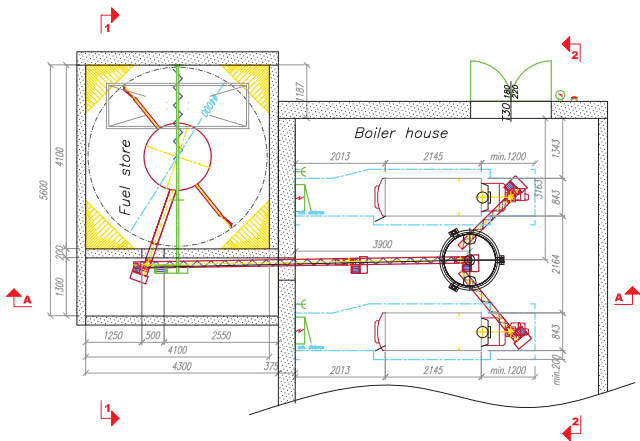

HPK-RA 150



# Wood chip heating

## Case study

### Inverary Castle Goes Green

The fairytale image evoked by the circular turrets and spires of Inverary Castle belies the 21st century outlook of the Campbell clan within.

When deciding to update the heating arrangements in the family's private apartments, the 13th Duke of Argyll chose to investigate the ecological advantages of a biomass system. Consultation with Irons Foulner, of Edinburgh, resulted in the installation of two Remeha 145kW biomass boilers, manufactured by Gilles.

Located in a remote boiler house and connected to the castle by underground heating mains, the biomass boilers provide heat and hot water to approximately one third of the castle. The environmental benefits are further enhanced because the boilers are fuelled by wood chips manufactured and supplied by the Inverary Estate, eliminating both the carbon emissions and costs of fuel transportation.

Fuelled by low to zero carbon fuels (wood chips or wood pellets), Remeha biomass boilers are modulating, fully controllable and automatic. The combustion chamber is lined with (replaceable) ceramic radiant fire-bricks and designed for high temperature operation.

Clean combustion is guaranteed by the high temperatures and the length of time the gases remain in the furnace. Maintenance is facilitated by the insulated door, designed to swing open fully to allow ease of access for the cleaning of all boiler flues.

Irons Foulner commented that the choice of boilers was based on experience of Remeha's technical expertise and back-up and said it was pleased with the attention and service received from both Remeha in the UK and Gilles in Austria.



# Pellet heating chimney data

## HPK-RA 12.5 - 150

PELLETS	Output [kW] @ nominal & part load	CO <sub>2</sub> -content [%] [experience average]	Flue gas mass flow [m <sup>3</sup> /hr]	Flue gas temperature [°C]	Residual flue fan pressure [Pa] on automatic mode*	Ø Flue pipe connection Connection height [m]
HPK-RA 12,5 / 5,1	12,5 3,5	12,6 9,7	21,9 7,6	170 120	8 1	160 1,4
HPK-RA 14,5 / 5,1	14,5 4,5	12,6 9,7	25,4 9,6	170 120	8 1	160 1,4
HPK-RA 19,5 / 5,1	19,5 5,5	12,6 9,7	35,6 13,0	170 120	8 2	160 1,4
HPK-RA 15 / 6,1	15 5	12,6 9,7	26,3 9,9	170 120	10 1	160 1,6
HPK-RA 20 / 6,1	20 6	12,6 9,7	36,5 9,9	170 120	10 3	160 1,6
HPK-RA 25 / 6,1	25 8	12,6 9,7	45,6 17,0	170 120	10 5	160 1,6
HPK-RA 30 / 9,2	30 9	12,6 9,7	52,8 19,8	170 120	10 5	180 1,9
HPK-RA 35 / 9,2	35 11	12,6 9,7	62,8 23,5	170 120	11 6	180 1,9
HPK-RA 40 / 9,2	40 12	12,6 9,7	72,9 27,0	170 120	10 6	180 1,9
HPK-RA 45 / 9,2	45 14	12,6 9,7	78,9 29,8	170 120	9 7	180 1,9
HPK-RA 49 / 9,2	49 15	12,6 9,7	86,0 32,3	170 120	9 7	180 1,90
HPK-RA 60 / 2,1	60 18	12,6 9,7	108 39,9	170 120	11 6	200 2,05
HPK-RA 70 / 3,1	70 21	12,6 9,7	128 47,1	170 120	9 8	200 2,05
HPK-RA 75 / 3,1	75 23	12,6 9,7	134 49,9	170 120	8 8	200 2,05
HPK-RA 85 / 3,1	85 26	12,6 9,7	153 57,2	170 120	6 6	200 2,05
HPK-RA 95 / 10,1	95 26	12,6 9,7	174 65,0	170 120	12 10	250 2,05
HPK-RA 100 / 10,1	100 30	12,6 9,7	174 65,4	170 120	12 10	250 2,05
HPK-RA 120 / 10,1	120 36	12,6 9,7	212 79,8	170 120	10 10	250 2,05
HPK-RA 145 / 4,2	145 44	12,6 9,7	260 97,5	170 120	6 5	250 2,05
HPK-RA 150 / 4,2	153 51	12,6 9,7	275 113,0	170 120	6 5	250 2,05

\*an increased draught is required for the log wood operation

**Notes:** 1. Changes of the direction of the flue only with 45° bends. 2. These figures are guidelines from Remeha-Gilles. 3. In general the flue must have as little horizontal and as much vertical as possible - please refer to notes on page 44

Conversion of [m<sup>3</sup>/std] to [g/s] > [m<sup>3</sup>/std] divided by 2,707 = [g/sec]

Conversion of [m<sup>3</sup>/std] to [kg/s] > [m<sup>3</sup>/std] divided by 2707 = [kg/s]

# Wood chip heating chimney data

## HPK-RA 12.5 - 150

WOODCHIPS	Output [kW] @ nominal & part load	CO <sub>2</sub> -content [%] [experience average]	Flue gas mass flow [m <sup>3</sup> /hr]	Flue gas temperature [°C]	Residual flue fan pressure [Pa] on automatic mode*	Ø Flue pipe connection Connection height [m]
HPK-RA 20 / 8.2	20 7.9	12.6 9.7	42.0 19.9	170 120	12 6	180 1.9
HPK-RA 25 / 8.2	25 7.9	12.6 9.7	53.9 19.9	170 120	11 7	180 1.9
HPK-RA 30 / 8.2	30 9	12.6 9.7	61.7 22.7	170 120	11 6	180 1.9
HPK-RA 35 / 8.2	35 11	12.6 9.7	73.9 27.0	170 120	11 7	180 1.9
HPK-RA 40 / 8.2	40 12	12.6 9.7	86.3 31.3	170 120	9 8	180 1.9
HPK-RA 45 / 8.2	45 15	12.6 9.7	97.5 35.5	170 120	8 8	180 1.9
HPK-RA 49 / 8.2	49 15	12.6 9.7	101 37.1	170 120	8 8	180 1.9
HPK-RA 60 / 2.1	60 18	12.6 9.7	126 46.0	170 120	10 9	200 2.05
HPK-RA 70 / 3.1	70 21	12.6 9.7	151 54.4	170 120	7 7	200 2.05
HPK-RA 75 / 3.1	75 23	12.6 9.7	157 57.7	170 120	6 6	200 2.05
HPK-RA 85 / 3.1	85 26	12.6 9.7	181 65.8	170 12	3 3	200 2.05
HPK-RA 95 / 10.1	95 29	12.6 9.7	204 75.0	170 120	11 10	250 2.05
HPK-RA 100 / 10.1	100 30	12.6 9.7	205 75.3	170 120	11 10	250 2.05
HPK-RA 120 / 10.1	120 36	12.6 9.7	248 91.8	170 120	6 6	250 2.05
HPK-RA 145 / 4.2	145 44	12.6 9.7	307 113	170 120	7 7	250 2.05
HPK-RA 150 / 4.2	150 49.5	12.6 9.7	318 127	190 120	6 5	250 2.05

\*an increased draught is required for the log wood operation

**Notes:** 1. Changes of the direction of the flue only with 45° bends. 2. These figures are guidelines from Remeha-Gilles. 3. In general the flue must have as little horizontal and as much vertical as possible - please refer to notes on page 44

Conversion of [m<sup>3</sup>/std] to [g/s] > [m<sup>3</sup>/std] divided by 2,707 = [g/sec]

Conversion of [m<sup>3</sup>/std] to [kg/s] > [m<sup>3</sup>/std] divided by 2707 = [kg/s]

# Industrial boiler

## Underfeed firing

HPKI-K

120-2000kW

The high-performance boiler is produced as a stress-free welded construction. The thermally insulated door at the front swings out completely permitting completely free access for cleaning all the boiler flues. The boiler is constructed in accordance with the natural combustion process of the fuel wood. The gasification combustion chamber built on a direct pass principle is fitted with a variable, ceramic (replaceable) radiator roof cladding. High combustion temperatures and a long furnace duration of the gases is the guarantee for a clean burning process.



HPKI-K 120-150 kW

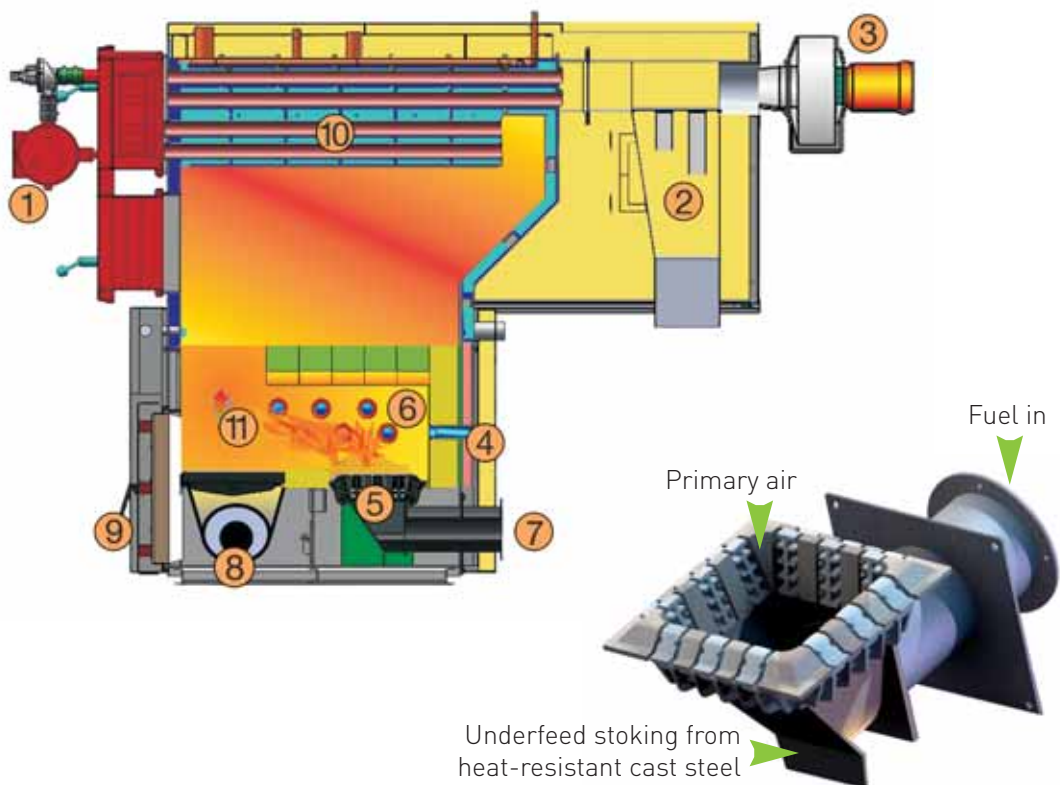



- Primary and secondary air are regulated by the combustion air fan and air dampers. Performance regulated by exhaust gas temperature, lambda probe sensor, combustion chamber temperature and boiler temperature
- Ceramic lining in high temperature resisting special concrete
- Underfeed fuel stoking with combustion retort in heat resistant steel, incl. grate rods in fire resisting cast alloy
- Combustion grate incl. grate rods in fire-resistant cast alloy
- Combustion chamber door in front wall

HPKI-K 180-2000 kW

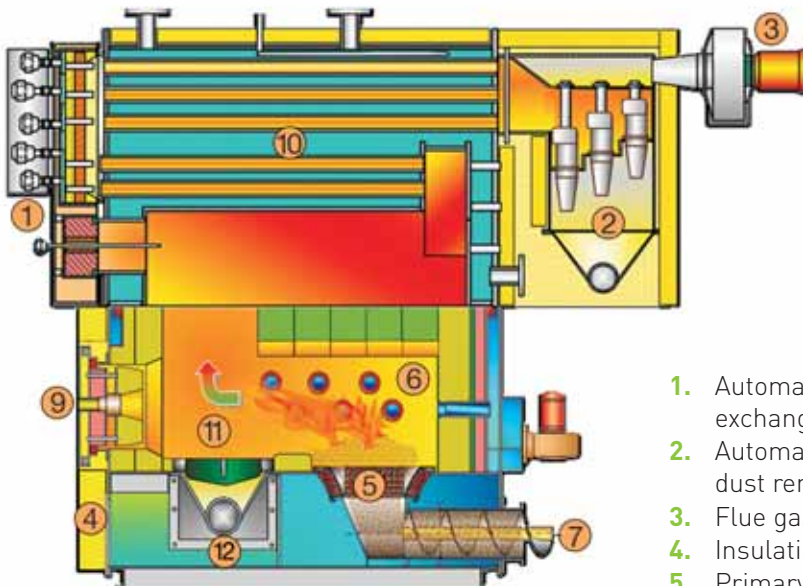

1. Automatic heat exchanger cleaning
2. Automatic flue gas dust removal
3. Flue gas fan
4. Insulation
5. Primary air
6. Secondary air
7. Fuel stoking
8. Automatic ash removal in to ash box
9. Combustion chamber door
10. Heat exchanger
11. Combustion chamber
12. Automatic ash removal in to ash box

# Industrial boiler

## Forward feed firing - Air cooled and water cooled step grate HPKI-R 150-5000 and HPKI-W 300-1600

The high-performance boiler is produced as a stress-free welded construction. The thermally insulated door at the front swings out completely permitting completely free access for cleaning all the boiler flues.

- Forward feed firing for drying, gasification and combustion of the fuel and ash transport from the combustion chamber
- Double-walled steel housing for pre-heating the combustion air and for cooling the inner anchoring plate of the ceramic lining
- Primary and secondary air are regulated by the combustion air fan and air dampers. Performance regulated by exhaust gas temperature, lambda probe sensor, combustion chamber temperature and boiler output performance
- Grate trolley with maintenance-free slide rails for reception of the moving grate bars in element structure for lateral assembly and disassembly



**HPKI-R 150-5000 kW**

Forward feed series air-cooled

### Forward feed firing - Air cooled

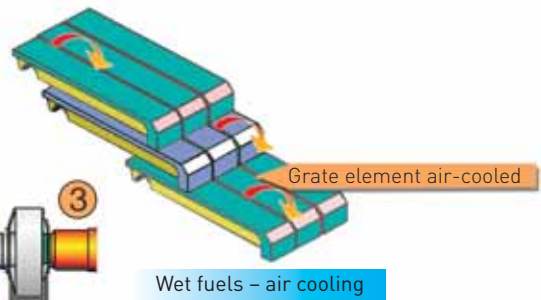
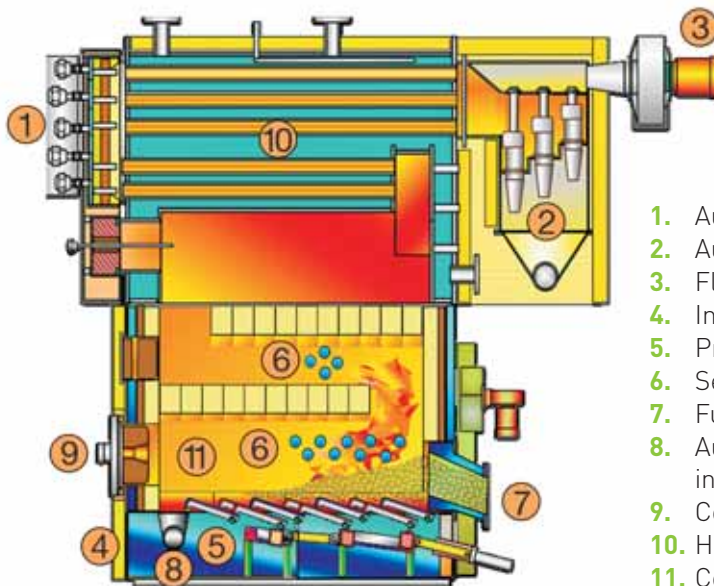

1. Automatic heat exchanger cleaning
2. Automatic flue gas dust removal
3. Flue gas fan
4. Insulation
5. Primary air
6. Secondary air
7. Fuel stoking
8. Automatic ash removal in to ash box
9. Combustion chamber door
10. Heat exchanger
11. Combustion chamber



**HPKI-W 300-1600 kW**  
Forward feed series water-cooled

- The grate bars are in fireproof caststeel alloy with special overlapping ribs to minimise fall-through from the grate and for cooling of the combustion air
- Moving grate moved by a hydraulic drive
- Radiator arched roof in the element structure, arched roof element in two parts for coping with expansion
- Ceramic lining in the combustion chamber in temperature-resistant concrete applied in layers
- Fire doors with double hinge in front wall of the combustion chamber
- Cleaning and servicing doors under the grate
- Ash removal at end of the grate, designed for automatic ash transport

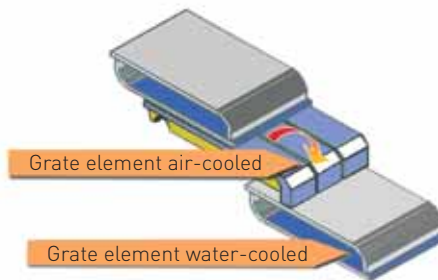

Dry fuel – water cooled

**Forward feed firing – Water cooled**

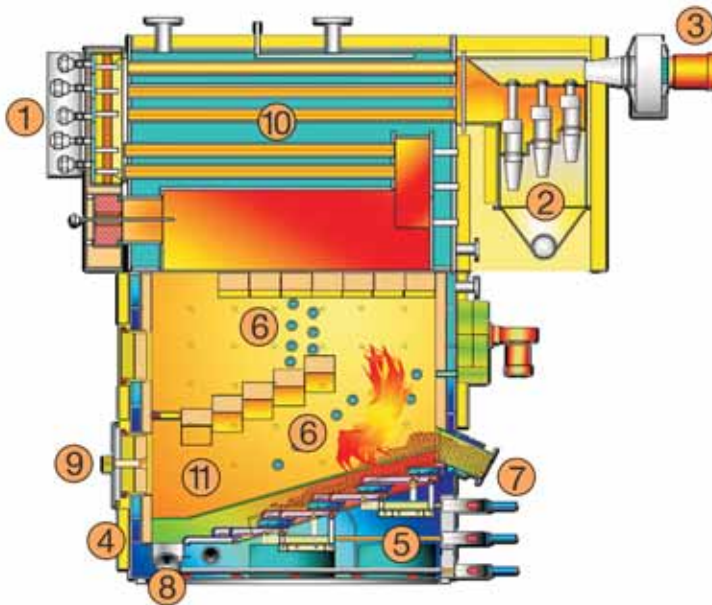

# Industrial boiler

## Basic dimensions\*

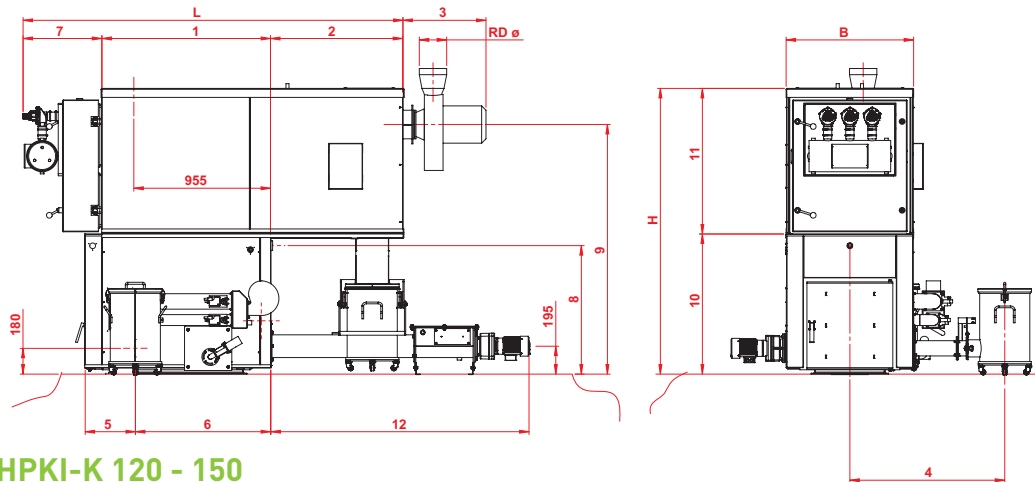

**HPKI-K 120 - 150**

**HPKI-K 120 - 150**

Type	Output in kW	L	W	H	Flow/Return	Weight total in tons	Water in litre	Flow coefficient in m <sup>3</sup> /h
120	120	2638	884	1986	65	2.10	290	45
150	150	2638	884	1986	65	2.10	290	45

**HPKI-K 180 - 2000**

Type	Output in kW	L	W	H	Flow/Return	Weight total in tons	Water in litre	Flow coefficient in m <sup>3</sup> /h
180	180	2990	1150	2200	65	3.66	830	48
240	240	3190	1150	2200	65	3.77	830	48
300	300	3450	1250	2250	80	4.67	1100	72
360	360	3450	1250	2250	80	4.67	1100	72
450	450	3950	1440	2480	100	7.05	1550	110
550	550	3950	1440	2480	100	7.05	1550	110
700	700	4620	1600	3000	100	10.43	2550	182
900	900	4620	1600	3000	100	10.43	2550	182
1200	1200	4990	1800	3500	125	13.74	3450	283
1600	1600	5590	1800	3550	150	15.40	3650	363
2000	2000	6250	2000	3950	200	20.90	5200	485

\*Please note dimensions shown do not include flanges for ash and flue fan motors etc. Please contact Remeha for guidance if dimensions are critical regarding moving boiler in to position.



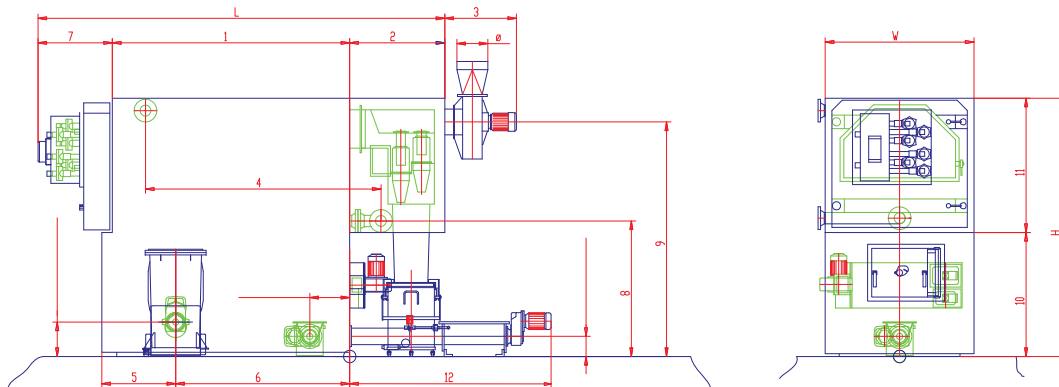

**HPKI-K 180 - 2000, HPKI-R 150-5000 and HPKI-W 300 - 1600**

**HPKI-R 150-5000 - Forward feed firing - Air cooled**

Type	Output in kW	L	W	H	Flow/Return	Weight total in tons	Water in litre	Flow coefficient in m <sup>3</sup> /h
150	150	2890	950	2420	50	3.97	290	30
180	180	2990	1150	2600	65	4.75	830	48
240	240	3190	1150	2600	65	4.8	830	48
300	300	3450	1250	2650	80	5.6	1100	72
360	360	3450	1250	2650	80	5.6	1100	72
450	450	3950	1440	2900	100	9.5	1550	110
550	550	3950	1440	2900	100	9.5	1550	110
700	700	4620	1800	3550	100	14.6	2550	182
900	900	4620	1800	3550	100	14.7	2550	182
1200	1200	4990	2000	4050	125	22.2	3450	283
1600	1600	5590	2000	4100	150	24.7	3650	363
2000	2000	6250	2320	4950	200	27.8	5200	485
2400	2400	6850	2320	4950	200	36.0	6050	515
3200	3200	7910	2800	6800	200	61.5	14300	640
4200	4200	9090	2800	7000	250	72.0	21600	840
5000	5000	10810	2800	8100	250	97.0	21600	1100

**HPKI-W 300 - 1600 - Forward feed firing - Water cooled**

Type	Output in kW	L	W	H	Flow/Return	Weight total in tons	Water in litre	Flow coefficient in m <sup>3</sup> /h
300	300	3450	1250	3000	80	7200	1700	72
360	360	3450	1250	3000	80	7200	1700	72
450	450	3950	1440	3300	100	10650	2350	110
550	550	3950	1440	3300	100	10650	2350	110
700	700	4620	1600	4100	100	15900	3850	182
900	900	4620	1600	4100	100	16000	3850	182
1200	1200	4990	1800	4800	125	21150	5550	283
1600	1600	5590	1800	4950	150	25000	6100	363

# Industrial boiler

## Transport systems



Cross auger with hydraulic cylinders

Remeha-Gilles rising auger with intermediate container for simultaneous feeding of two boilers from one fuel store.



### Push rod transport system



Cross auger  $\varnothing$  250 mm



Push rod up to 3 metre width possible

## SPECIAL FEATURES - Hydraulic direct feed

For special fuels up to G100



Hydraulic - direct feed up to 1 metre wide



Fully ceramic-lined combustion chamber with air-cooled grate

**Wood chip transport industrial hinged arm**  
Up to 550 kW

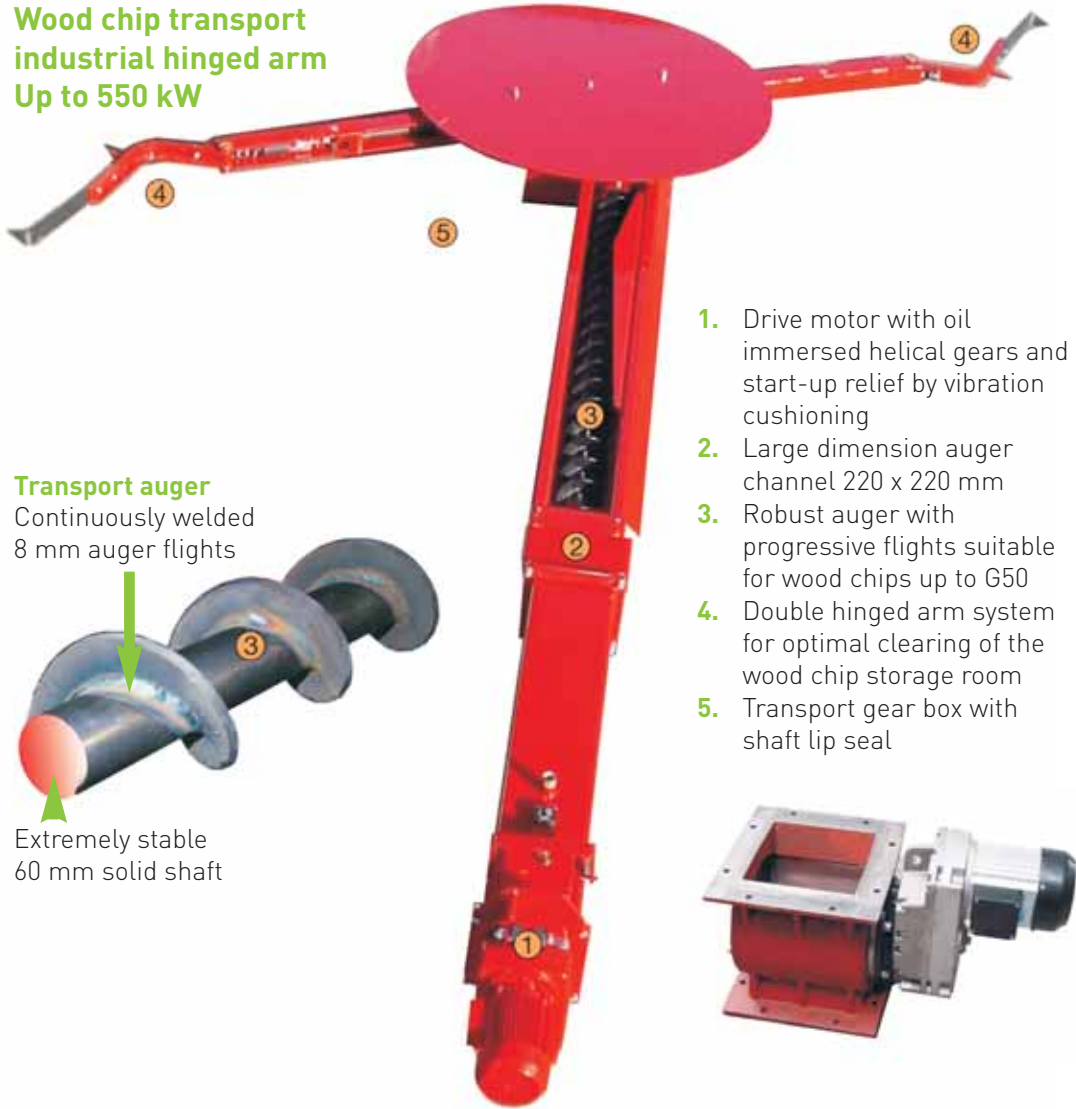

1. Drive motor with oil immersed helical gears and start-up relief by vibration cushioning
2. Large dimension auger channel 220 x 220 mm
3. Robust auger with progressive flights suitable for wood chips up to G50
4. Double hinged arm system for optimal clearing of the wood chip storage room
5. Transport gear box with shaft lip seal

**Transport auger**  
Continuously welded  
8 mm auger flights

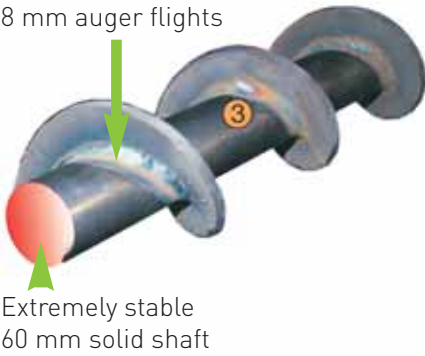

Extremely stable  
60 mm solid shaft

**Cell wheel**

100% protection against burn-back! The multi-tested full-metal cell wheel reliably interrupts the boiler with the storage room and thus provides **100% protection against burnback**. The blades are attached to the running wheel at an offset angle to the rotary axis to enhance the cutting action. In addition, the blades are slightly curved, which prevents noise generation and reduces compressive forces. A fixed cutting edge is integrated in the stable and noise-damping cast enclosure to reduce the size of longer pieces of material.



**Energy-saving 4-chamber system with low running surface**

# Industrial heating

## Planning examples

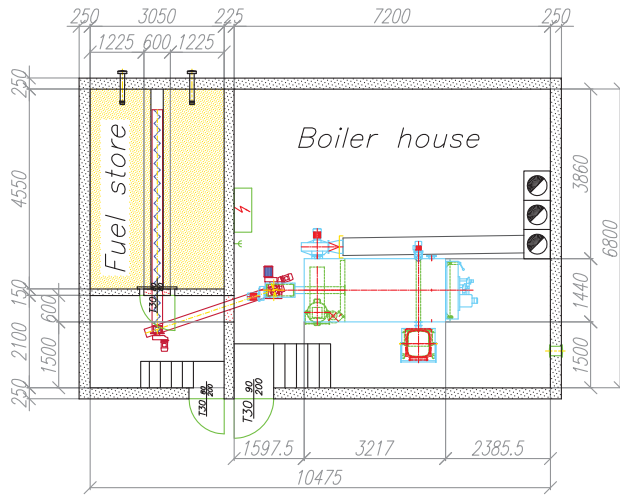

HPKI-K 550 with pellet transport system

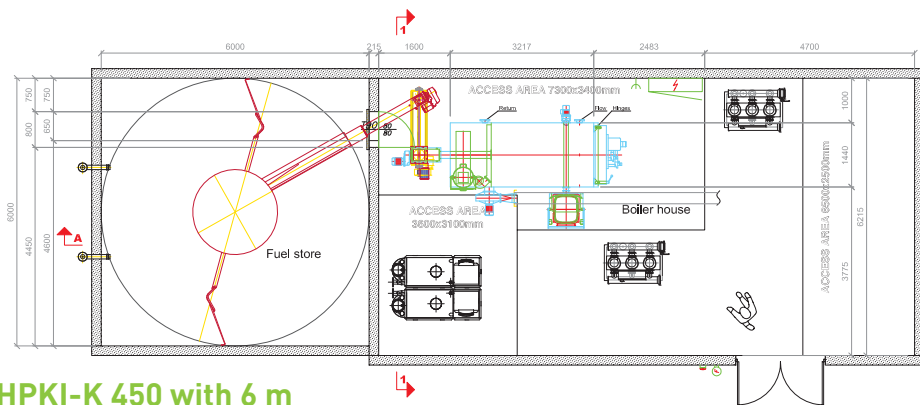

HPKI-K 450 with 6 m hinged arm sweep collector

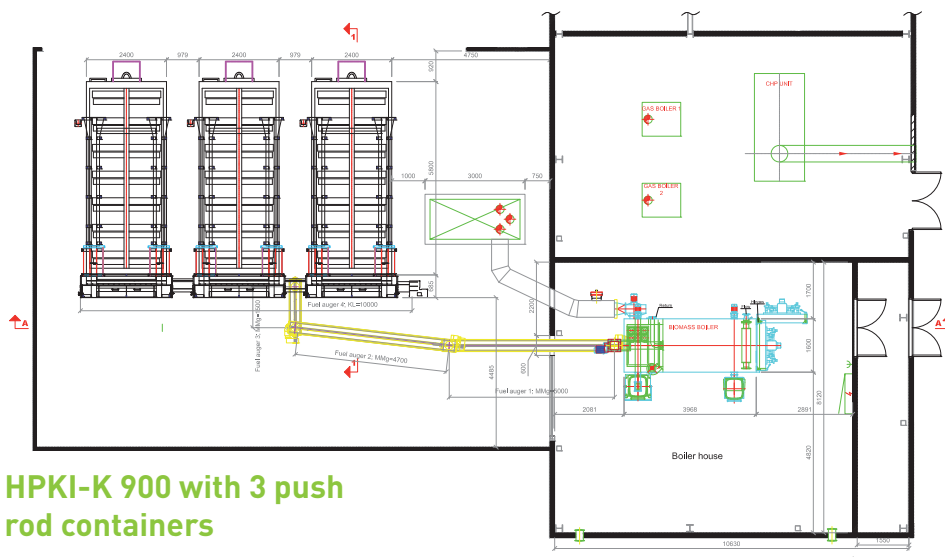

HPKI-K 900 with 3 push rod containers

# Industrial heating

## Case study

### Remeha's Stansted Airport biomass installation outperforms all expectations

State-of-the-art biomass boiler technology from Remeha has ensured that Stansted Airport's new £50million terminal extension is a low to zero carbon zone. And, says Stansted's head of environment, the boiler has outperformed all expectations during its first winter of operation.

The 2000kW biomass heating boiler is one of the biggest in commercial use in the UK. Supplied by Remeha and manufactured by European company Gilles Austria, it is powered by woodchips.

The boiler is part of BAA's commitment to reducing the environmental impacts of development and day-to-day operations. It makes the new airport extension, completed last year, a low to zero carbon building.

Indeed its performance since last November has proved so efficient that it is now the primary boiler for the whole airport. Results indicate the biomass technology is set to help reduce predicted annual gas consumption at the airport by nearly 40 per cent.

"To say we're delighted with the performance of the new biomass boiler is an understatement," says head of environment at Stansted Airport, Andy Jefferson.

"We set out to ensure the recent terminal extension would be carbon neutral but performance data so far indicates those savings go much further, with results between November 2008 and March 2009 alone showing that gas consumption at Stansted was around 60 per cent of the predicted forecasts for this period, and over 30 per cent lower than the same period for the previous year. And all this despite it being one of the coldest winters on record for over a decade.

"Whilst initiatives such as our asset replacement programme have contributed

to these overall results, the introduction of biomass technology has by far been the largest contributor.

"We're proud to maintain our leading position as the largest UK airport to hold ISO14001 accreditation for environmental management and shall also publish our first Airport Carbon Footprint before this summer which will outline how our footprint is comprised today, and help inform future decisions relating to emissions management at Stansted moving forward."



# Industrial heating chimney data

## HPKI-K / R / W 120kW - 2000kW (Pellets)

PELLETS	Output [kW] @ nominal & part load	CO <sub>2</sub> -content [%] [experience average]	Flue gas mass flow [m <sup>3</sup> /hr]	Flue gas temperature [°C]	Residual flue fan pressure [Pa] on automatic mode	Ø Flue pipe connection + Flue pipe [mm]	Ø Chimney [mm]
HPKI-K 120	120	12.6	215	170	9	200	250
	40	9.7	88.7	120	8	250	
HPKI-K 150	150	12.6	266.0	170	8	200	250
	45	9.7	99.8	120	8	250	
HPKI-K (R,W) 180	180	12.6	326.0	170	8	200	250
	54	9.7	121	120	5	250	
HPKI-K (R,W) 240	240	12.6	423.2	170	8	200	300
	72	9.7	158	120	7	300	
HPKI-K (R,W) 300	300	12.6	537.9	170	12	200	300
	90	9.7	74.5	120	11	300	
HPKI-K (R,W) 360	360	12.6	656.4	170	11	250	350
	108	9.7	243.4	120	11	350	
HPKI-K (R,W) 450	450	12.6	797.9	170	9	300	400
	135	9.7	298.3	120	9	400	
HPKI-K (R,W) 550	550	12.6	1003	170	11	300	450
	165	9.7	374.0	120	11	400	
HPKI-K (R,W) 700	700	12.6	1234	170	9	300	450
	210	9.7	461.6	120	7	400	
HPKI-K (R,W) 900	900	12.6	1641	170	9	360	500
	270	9.7	608.5	120	7	500	
HPKI-K (R,W) 1200	1200	12.6	2163	170	11	400	600
	360	9.7	802.5	120	11	550	
HPKI-K (R,W) 1600	1600	12.6	2901	170	13	400	600
	480	9.7	1076	120	13	550	
HPKI-K ( R ) 2000	2000	12.6	3647	170	13	400	600
	600	9.7	1345	120	11	600	

**Notes:** 1. Changes of the direction of the flue only with 45° bends. 2. These figures are guidelines from Remeha-Gilles. 3. In general the flue must have as little horizontal and as much vertical as possible - please refer to notes on page 44

Conversion of [m<sup>3</sup>/std] to [g/s] > [m<sup>3</sup>/std] divided by 2,707 = [g/sec]

Conversion of [m<sup>3</sup>/std] to [kg/s] > [m<sup>3</sup>/std] divided by 2707 = [kg/s]

# Industrial heating chimney data

## HPKI-K / R / W 120kW - 2000kW (Woodchips)

WOODCHIPS	Output [kW] @ nominal & part load	CO <sub>2</sub> -content [%] [experience average]	Flue gas mass flow [m <sup>3</sup> /hr]	Flue gas temperature [°C]	Residual flue fan pressure [Pa] on automatic mode	Ø Flue pipe connection + Flue pipe [mm]	Ø Chimney [mm]
HPKI-K 120	120	12.6	249.7	170	8	200	250
	40	9.7	101.7	120	5	250	
HPKI-K 150	150	12.6	312.1	170	7	200	250
	45	9.7	114.5	120	5	250	
HPKI-K (R,W) 180	180	12.6	385.2	170	4	200	250
	54	9.7	140.0	120	4	250	
HPKI-K (R,W) 240	240	12.6	485.4	170	12	200	300
	72	9.7	181.4	120	10	300	
HPKI-K (R,W) 300	300	12.6	631.0	170	11	200	300
	90	9.7	231.7	120	10	300	
HPKI-K (R,W) 360	360	12.6	775.0	170	9	250	350
	108	9.7	281.3	120	8	350	
HPKI-K (R,W) 450	450	12.6	936.1	170	9	300	400
	135	9.7	343.8	120	8	400	
HPKI-K (R,W) 550	550	12.6	1184	170	11	300	450
	165	9.7	429.6	120	10	400	
HPKI-K (R,W) 700	700	12.6	1448	170	11	300	450
	210	9.7	528.9	120	10	400	
HPKI-K (R,W) 900	900	12.6	1937	170	8	360	500
	270	9.7	699.2	120	7	500	
HPKI-K (R,W) 1200	1200	12.6	2539	170	11	400	600
	360	9.7	922.0	120	10	550	
HPKI-K (R,W) 1600	1600	12.6	3424	170	15	400	600
	480	9.7	1236	120	13	600	
HPKI-K ( R ) 2000	2000	12.6	4280	170	17	400	600
	600	9.7	1545	120	15	600	

**Notes:** 1. Changes of the direction of the flue only with 45° bends. 2. These figures are guidelines from Remeha-Gilles. 3. In general the flue must have as little horizontal and as much vertical as possible - please refer to notes on page 44

Conversion of [m<sup>3</sup>/std] to [g/s] > [m<sup>3</sup>/std] divided by 2,707 = [g/sec]

Conversion of [m<sup>3</sup>/std] to [kg/s] > [m<sup>3</sup>/std] divided by 2707 = [kg/s]

# Containers for heating systems

Low construction costs - rapid implementation

12.5kW - 150kW



Remeha-Gilles heating containers are the ideal, fast and cost-effective solution when there is little space in the existing building.

Another advantage: Easy transfer or expansion possible. The containers are in reinforced concrete and meet all fire protection regulations.

## **Single and double containers up to 150kW including:**

- Installation (flow+return)
- Electrical installation
- Stainless steel chimney
- Safety equipment
- Fuel supply couplings
- All doors and gates
- Ventilation (incl. ventilation grill)
- Without boiler and transport system
- Storage room 20 – 45 m<sup>3</sup>, individual

(Incl. installation, incl. chimney of high-grade steel, incl. safety devices, incl. blowers junctions, incl. all fire protection doors, boiler and fuel delivery equipment to suit customer requirements.)



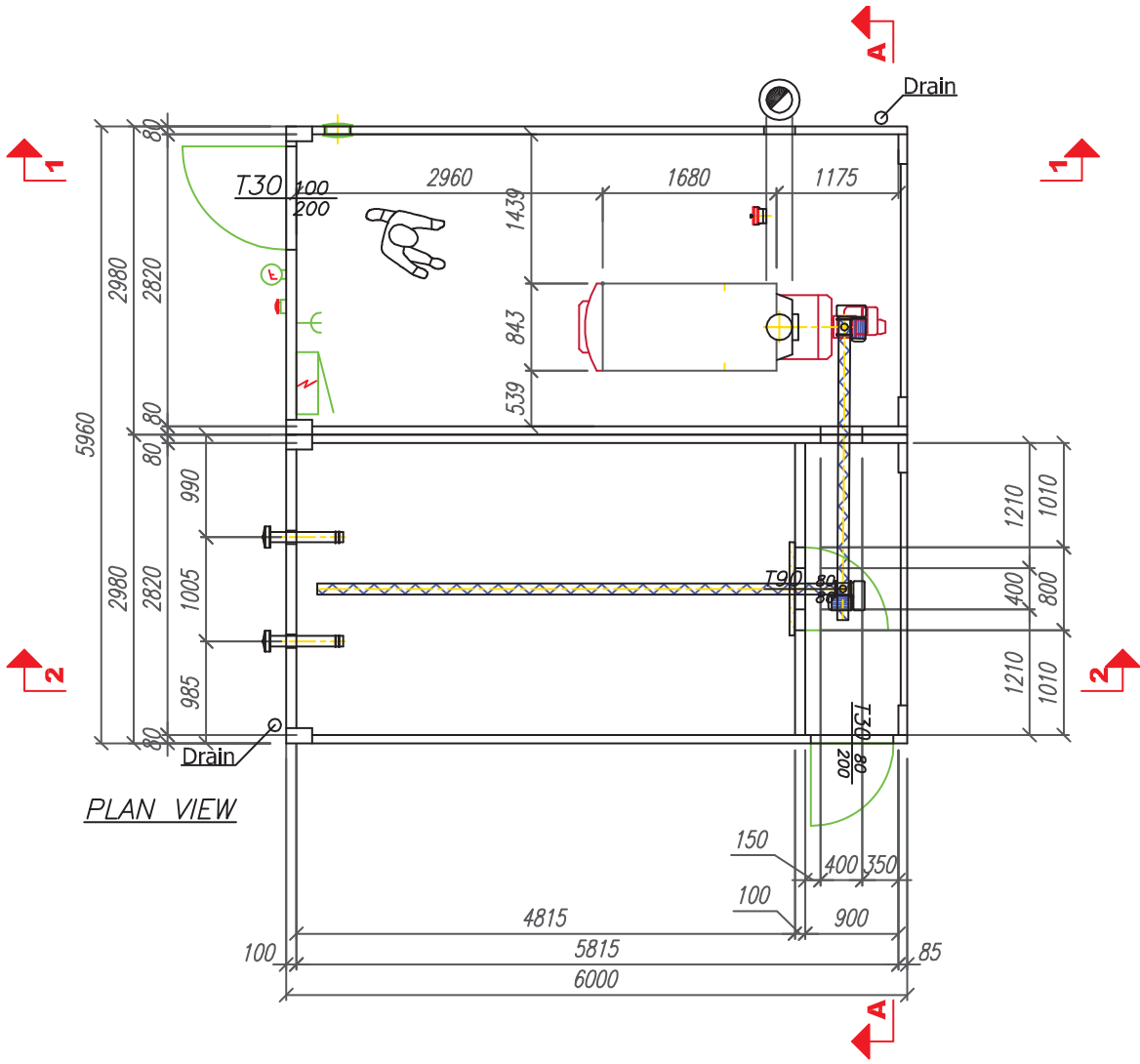

# Piping a biomass boiler up to a heating system

Uniquely, the Remeha-Gilles biomass boiler has the combustion process under full control. This means that a buffer vessel doesn't always need to be fitted if the boiler is piped into a low loss header as shown below.

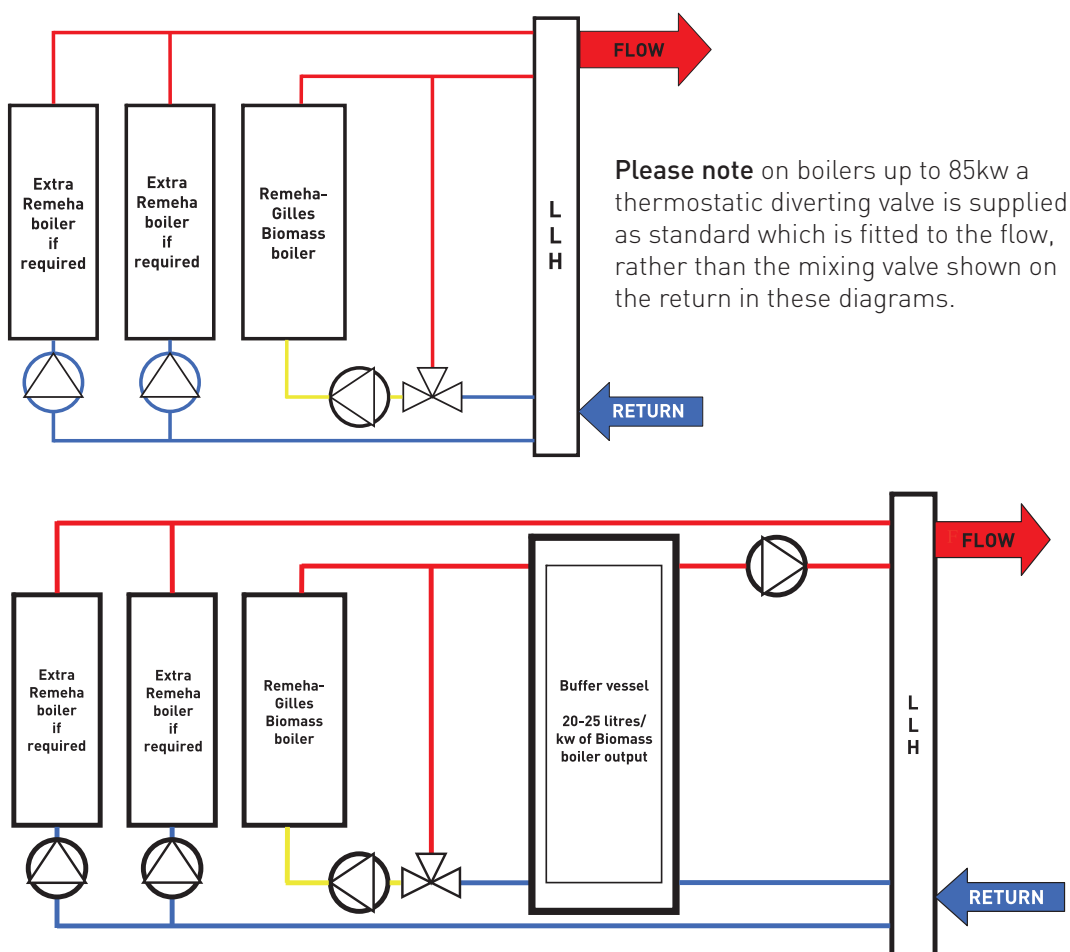

Typical Remeha-Gilles biomass schematic showing option of extra boilers if required. Biomass boiler pump and divert valve supplied as standard- up to 150 kW, HPK-RA Range (isolation valves etc omitted for clarity). The diagram above shows that the biomass boiler can be piped up like any other boiler and also in conjunction with any other boiler. The 3 port mixing valve and boiler pump are supplied with the boiler(HPK-RA) and are designed to get the nominal flow through the boiler and keep the return temperature up to 60-63 deg C. They are controlled by the boiler so require no extra

electrical supply - Supplied as standard 20° Delta t for header / buffer within 3m of boiler - optional extra 11 degree kit.

## When would a buffer vessel be desirable?

A buffer vessel can be used for 3 main reasons (but not restricted to):

- If 'instant' heat is required at any time e.g. in a greenhouse that has to be kept warm immediately once the inside set temperature falls in the evening.

- A buffer vessel can be used to effectively increase the size of a boiler by letting it create and store heat overnight ready for the cold morning start - this applies to all boilers not just biomass.
- If the boiler is connected only to a Plate Heat Exchanger/s and/or if there is a

possibility of the demand for heat being taken away without any overrun e.g. only looking after air handling units which may all switch off at the same time once a set outside temperature is reached or similar situation.

## What capacity does the fuel store need to be?

### Calculation is dependent upon a number of factors:

- What output is the biomass boiler in kw?
- How many hours a week will it be in operation?
- Which type of fuel – chips or pellets?
- How often is it desirable to have fuel deliveries?
- What capacity is the delivery lorry?

### For example

A 145kw boiler in a primary school working say 6hrs a day at full output burning wood chips will burn the following amount of fuel per week.

$145\text{kw} \times 6\text{hrs per day} \times 5\text{ days per week} = 4350\text{ kw/hrs per week.}$

$4350\text{ divided by }800\text{ (the amount of kw/hrs per m}^3\text{ of chips)} = 5.43\text{m}^3\text{ per week.}$

Most fuel delivery lorries carry about 30m<sup>3</sup> of fuel so in this instance if a 36/38m<sup>3</sup> store could be created a delivery would be needed about every 6 weeks without the store needing to be fully empty to receive a full load.

A suitable store would be about 3.5m x 3.5m x 3m deep.

### Another example

A 100kw boiler in a sports centre working say 12hrs a day at full output burning pellets will burn the following amount of fuel per week.

$100\text{kw} \times 12\text{hrs per day} \times 7\text{ days per week} = 8400\text{kw/hrs per week.}$

$8400\text{ divided by }3000\text{ (the amount of kw/hrs per m}^3\text{ of pellets)} = 2.8\text{m}^3\text{ per week.}$

That would be a full lorry load approx every 10 weeks or a half load every month or so.

# Important information

## Water treatment

It is generally considered good practice to treat the system water. The biomass boilers have a steel heat exchanger so a suitable inhibitor should be used for steel and all other metals in the heating system.

## Combustion air requirements

The combustion air requirement for the biomass boilers is as follows:

- Kw output of the boiler(s) x 3.222 + 80cm<sup>2</sup>
- For example a 145 kW boiler would need 547cm<sup>2</sup> of free area air inlet
- A 100 kW and 45 kW together in the same boiler house would also need 547cm<sup>2</sup>

Any conventionally flued appliances e.g. pressure jet, water heater, atmospheric or conventionally flued Quinta/210 etc will need their combustion air in addition to the above in accordance with standard BS6644 calculation.

## Flueing requirements

The boilers must be connected to a flue with natural draught- long horizontal and short vertical runs are to be avoided. Flue fans- supplied by others- can be incorporated but add additional cost and complexity to the project. Boilers must be flued in accordance with BS 6644 and comply with the requirements of the Clean Air Act.

Reference should be made BS 6644 & the Clean Air Act.

Only clean wood fuel may be used & can generally be regarded as a Very Low Sulphur (VLS) fuel.

- The boilers must have their own flue, they cannot share with other boilers, water heaters or biomass boilers.
- The flue gas temperature is between 130 deg C and 200 deg C.
- The services of a specialist flue company should be considered for final flue design, which should include clean out hatches, draught stabilisers and explosion doors.

## Flueing environmental issues

All combustion causes pollution. When selecting your fuel you are also inevitably

selecting the pollution that comes as a consequence of that decision. All Remeha-Gilles boilers when correctly installed are certified by AEA Technology\* as suitable for use in Smokeless Zones and meet with all UK regulatory standards. All equipment certification is given based on the use of clean fuel. Clean fuel is essential otherwise you may be in breach of emissions regulations.

**Other air pollutants of concern**, but by no means exclusive to biomass combustion include:

**PM10 Particles** - Remeha-Gilles fully automated boilers are class leaders with low PM10 emissions.

**PM10 Levels** will vary significantly with fuel quality. Pellets produce less PM10 than chips and may be a more suitable fuel choice for built up areas. PM10 emissions are of less concern in rural and suburban areas where existing PM10 levels are likely to be low. PM10 and 2.5 can be reduced to virtually zero with the use of ceramic filters on the flue outlet, available from Remeha.

**Sulfur Oxides (SOx)** cause acid rain. Modern wood systems have 1/6 the SO<sub>2</sub> emissions of fuel oil.

**Nitrogen Oxides (NOx)** produced by all combustion processes cause ozone, smog, acid rain and respiratory problems.

**Carbon Monoxide (CO)** is produced by all fuel combustion processes. The level produced by wood combustion depends very much on how well the system is set up and maintained. CO emissions from wood burning are of relatively minor concern to air quality, except in some areas that already have high levels of CO in the air from traffic exhaust.

**Volatile Organic Compounds (VOCs)** are a large family of air pollutants, some of which are produced by fuel combustion. Some are toxic, others are carcinogenic. VOCs elevate ozone and smog levels in the lower atmosphere, causing respiratory problems. Both wood and oil combustion produce VOCs—wood is higher in some compounds and oil is higher in others. VOC emissions can be minimized with good combustion practices.

Most of these issues are relevant to all combustion processes not solely wood biomass and can be resolved by ensuring the correct chimney height. As with all installations, reference to the Clean Air Act and BS6644 is recommended. AEA Technology\* can carry out an on-site

environmental impact study to fully assess all of the air quality issues surrounding an installation if the client feels this is necessary.

\*[www.aeat.co.uk](http://www.aeat.co.uk)

# Minimum clearances

## HPKI-K 180-2000kW

1. Required to fully open the heat exchanger door.
2. Required for maintenance and service works.

With a double door in front of the heat exchanger, with an equivalent width as the boiler the recommended clearance is not required.

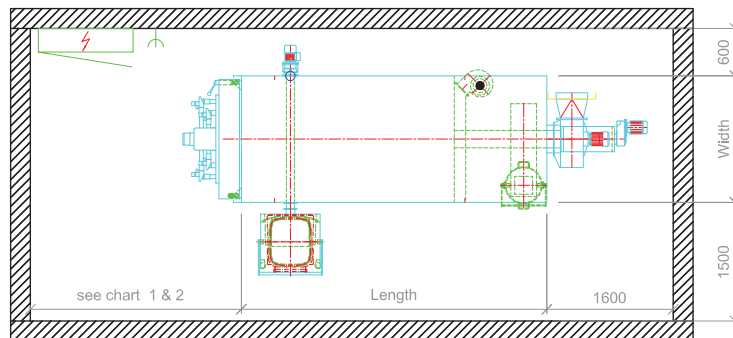

Min. clearance, boiler with 240l ash bin

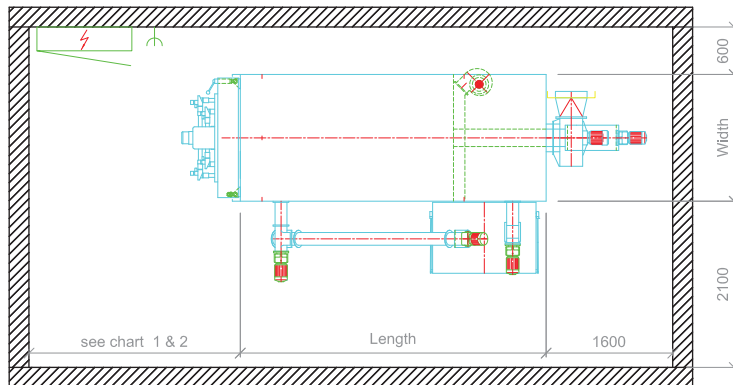

Min. clearance, boiler with 800l ash bin

Boiler specification	1 minimum clearance	2 recommended clearance	Length	Width
180kW and 240kW	1150mm	1600mm	2320/2520mm	1150mm
300kW and 360kW	1250mm	1800mm	2720mm	1250mm
450kW and 550kW	1450mm	2300mm	3220mm	1450mm
700kW and 900kW	1600mm	2700mm	3880mm	1600mm
1200kW	1800mm	3000mm	4230mm	1800mm
1600kW	1800mm	3400mm	4830mm	1800mm
2000kW	2000mm	3800mm	5460mm	2000mm



# How you can contact us

Please call the Remeha renewable department on:

# 0118 974 3065

## PRE AND AFTER SALES SERVICE

Our dedicated pre and after sales team is ready to give you the support you need as part of the quality package that Remeha offers as standard with all products.

## GENERAL OFFICE

Broag Ltd. Head Office  
Remeha House  
Molly Millars Lane  
Wokingham  
Berkshire RG41 2QP  
T: 0118 978 3434  
F: 0118 978 6977  
E: boilers@remeha.co.uk

[www.remeha.co.uk](http://www.remeha.co.uk)



**remeha**  
creating energy solutions

**GILLES**  
BIOMASS HEATING



Remeha is committed to carbon offsetting



# TreadLightly

ON THE PLANET



## Broag Ltd. Head Office

Remeha House  
Molly Millars Lane  
Wokingham  
Berkshire RG41 2QP  
T: 0118 978 3434  
F: 0118 978 6977  
E: boilers@remeha.co.uk

[www.remeha.co.uk](http://www.remeha.co.uk)

The data published in this technical sales leaflet is based on the latest information (at date of publication) and may be subject to revisions. It should be read in conjunction with our full technical brochure (available on request). We reserve the right to continuous development in both design and manufacture, therefore any changes to the technology employed may not be retrospective, nor may we be obliged to adjust earlier supplies accordingly. Please note: all advice in this booklet is given in good faith. However Remeha will not be held liable for information which subsequently is found to be outdated or inaccurate. Issue 2 date: 02/08/2010



PART OF BDR THERMEA



Remeha is committed to carbon offsetting