

Operating instructions

Gas fired condensing boiler Logano plus GB312



Buderus

1	For your safety	3
1.1	Notes regarding these instructions	3
1.2	Correct use	3
1.3	Key to symbols	3
1.4	Please observe these notes	3
1.4.1	If you smell gas.	3
1.4.2	Tips on the boiler room.	4
2	Product description	5
2.1	Components on the Logano plus GB312 boiler	5
2.2	BC10 controls	5
3	Operation of the heating system	6
3.1	Switching on the heating system	6
3.1.1	Starting the heating system via the control panel and programming unit	6
3.2	Switching off the heating system	7
3.3	Emergency measures	7
3.4	Checking the operating pressure, topping up with heating water and bleeding the system	7
3.4.1	When should you check the operating pressure?	7
3.4.2	Checking the operating pressure.	8
3.4.3	Filling the heating system and checking for leaks	8
3.5	Why is regular maintenance important?	11
4	Troubleshooting	12
4.1	Recognising and resetting faults.	12

Operating pressure	
Design operating pressure (optimum value):	_____ bar
Maximum heating system operating pressure: (standard = 3 bar)	_____ bar

Use the following fuel only:

Company stamp/date/signature

1 For your safety

1.1 Notes regarding these instructions

These installation and maintenance instructions contain important information for the safe and correct installation, initial start-up and maintenance of this boiler.

In the following, the Logano plus GB312 gas-fired condensing boiler will generally be referred to as the boiler.

1.2 Correct use

The boiler is designed for generating heating water and DHW, for example, in homes or apartment buildings.

1.3 Key to symbols

The following symbols are used in this manual:



RISK TO LIFE

Identifies possible risks, which may lead to serious injury or death if appropriate care is not taken.



RISK OF INJURY/ SYSTEM DAMAGE

Identifies hazardous situations, which could lead to medium or slight injuries or to material losses.



USER NOTE

Tip for the optimum utilisation and setting of the control(s) plus other useful information.

→ Cross-references

Cross-references to a specific point or another document are identified by an arrow →.

1.4 Please observe these notes

You will learn how to use your heating system by

- letting your installer instruct you when the system is handed over and
- reading these operating instructions carefully.

Do not carry out any work on the boiler that is not described in these operating instructions.



WARNING!

RISK TO LIFE

by employing unqualified personnel.

- Installation, commissioning and maintenance must only be carried out by a specialist installer. Work on electrical and fuel-bearing components in particular must only be carried out by suitably qualified personnel.

1.4.1 If you smell gas



WARNING!

RISK TO LIFE

through the explosion of volatile gases. If you can smell gas, there is a risk of explosion.

- Extinguish all naked flames. Do not smoke. Do not use lighters.
- Prevent sparks. Do not operate electrical switches, including telephones, plugs or doorbells.
- Close the main gas shut-off valve.
- Open windows and doors.
- Warn all occupants, but do not use doorbells or mobiles or other electrical devices.
- Leave the building.
- Call your gas supplier and your installer from outside the building.
- If necessary, notify police or fire services.
- If you hear gas escaping, evacuate the affected area immediately.

1.4.2 Tips on the boiler room



WARNING!

RISK TO LIFE

from poisoning.

In open-flue operation, insufficient ventilation can lead to dangerous flue gas leaks.

- Never block off or obstruct air ducts and vents or reduce their size.
- Keep the boiler room doors closed.
- Protect the boiler room and particularly the combustion air inlet against ingress of small animals, e.g. by the use of grilles.
- If an obstruction cannot be removed immediately, the boiler must not be operated.



WARNING!

RISK OF FIRE

from flammable materials or liquids.

- Never store flammable materials or liquids in the boiler room.

2 Product description

2.1 Components on the Logano plus GB312 boiler

The boiler is a gas-fired condensing boiler with an aluminium heat exchanger.

The boiler comprises:

- Control panel
- Frame and casing
- Boiler block with insulation
- Gas burner

The control panel monitors and controls all electrical boiler components.

The boiler block transfers the heat generated by the burner to the heating water. The insulation prevents energy losses.

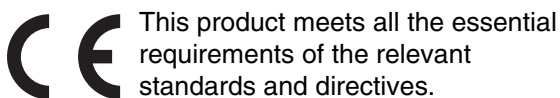

This product meets all the essential requirements of the relevant standards and directives.

2.2 BC10 controls



USER NOTE

- Further information about the controls can be found in the → BC10 base controller documentation.

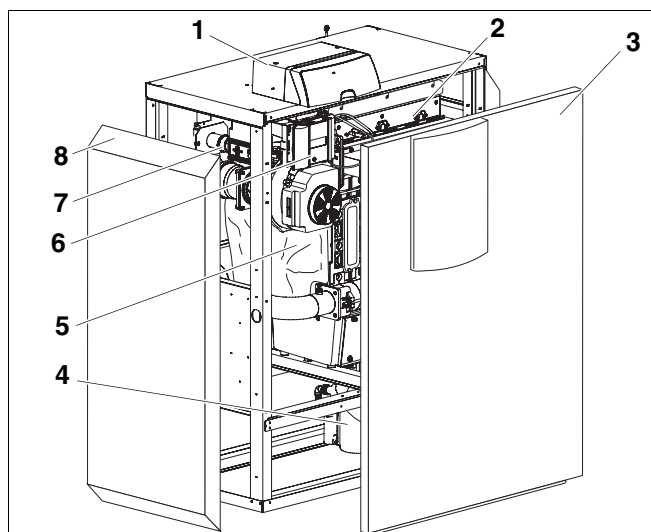

Fig. 1 Logano plus GB312 boiler

- 1 Control panel
- 2 Gas burner
- 3 Boiler front panel
- 4 Siphon
- 5 Boiler block with insulation
- 6 Burner control unit
- 7 Gas train
- 8 Boiler casing

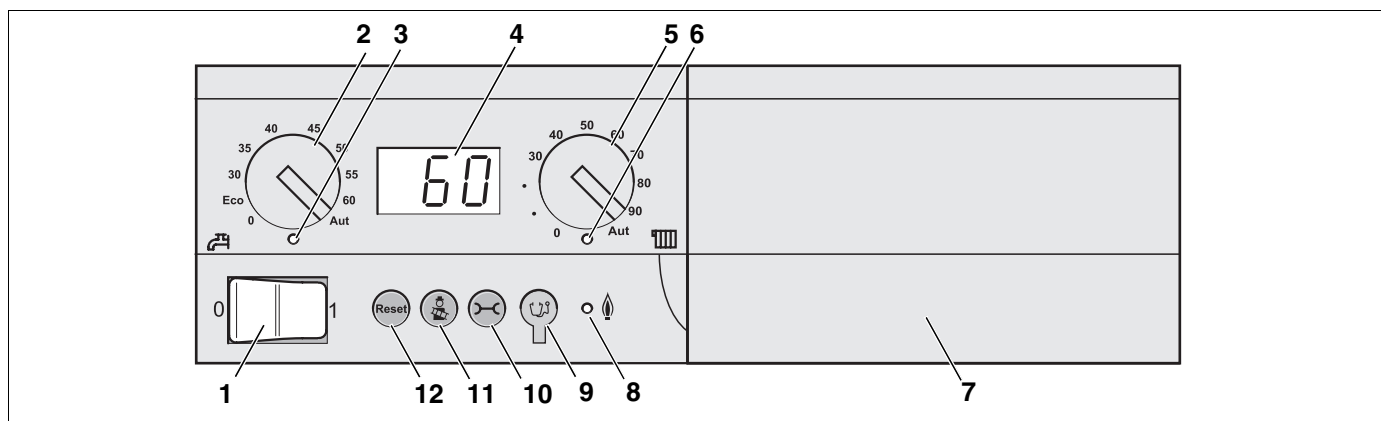

Fig. 2 Controls on the BC10 base controller

- Item 1:** ON/OFF switch
- Item 2:** Dial for setting DHW temperature
- Item 3:** "DHW heating" LED
- Item 4:** Status display
- Item 5:** Dial for maximum boiler temperature when in heating mode
- Item 6:** "DHW demand" LED
- Item 7:** Base plate with slot for a programming unit, e.g. RC30 (behind fascia)
- Item 8:** "Burner" (ON/OFF) LED
- Item 9:** Diagnostic plug
- Item 10:** "Status display" button
- Item 11:** "Chimney sweep" button for flue gas test and manual mode
- Item 12:** "Reset" button

3 Operation of the heating system

3.1 Switching on the heating system

Before switching the system on, check

- that the operating pressure is high enough,
- that the fuel supply at the main shut-off valve is open and
- that the heating system emergency stop switch is switched on.

3.1.1 Starting the heating system via the control panel and programming unit

- Set both dials on the control panel to "AUT" (automatic mode). In this setting, the programming unit takes over control.

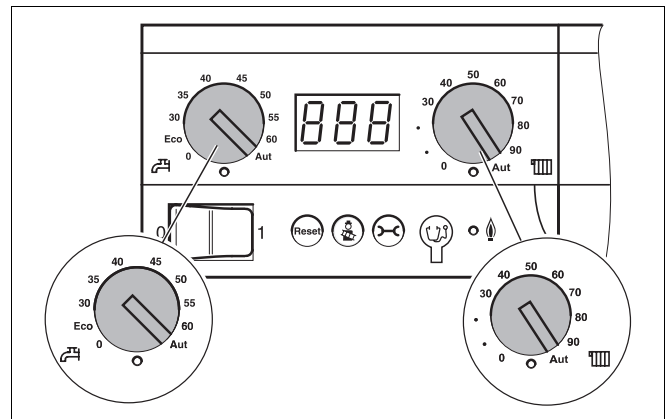

Fig. 3 Setting the control panel

- Switch the ON/OFF switch ON (position "1"). The control panel checks the current system status and the burner starts if required.

If the boiler detects a heat demand, the start program commences and approx. 30 seconds later the burner fires up. A heat demand is triggered if the heating or DHW temperature falls below its set value. The LED below the relevant dial illuminates.

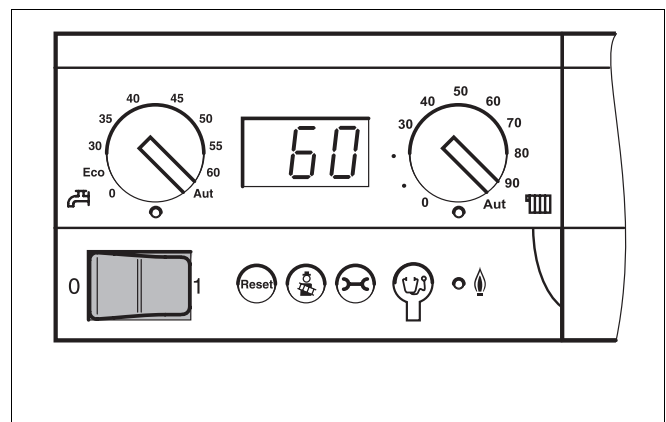

Fig. 4 Switching on the heating system

- Check and make sure the following settings on the programming unit are set:
 - Automatic operating mode
 - Required room temperature
 - Required DHW temperature
 - Required heating program



USER NOTE

- Operating instructions, for example how to set temperatures, can be found in the → programming unit documentation.

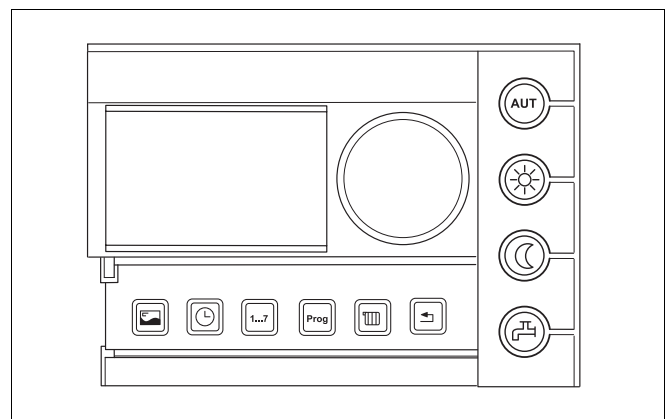

Fig. 5 Programming unit (e.g. RC30, with open flap)

3.2 Switching off the heating system

- Switch the ON/OFF switch on the control panel OFF (position "0"). This switches the boiler and all its components OFF (for example the burner).
- Close the main fuel shut-off valve.



SYSTEM DAMAGE

through frost.

CAUTION!

The heating system can freeze up in cold weather if it has been switched off.

- Leave the heating system switched ON for as long as possible.
- Protect your heating system against freezing by draining the heating system and DHW pipework at the lowest possible point.

3.3 Emergency measures

In the event of an emergency, e.g. a fire, proceed as follows:

- Close the main fuel shut-off valve.
- Isolate the heating system from the mains power supply using the heating system emergency stop switch or the corresponding domestic fuse.

3.4 Checking the operating pressure, topping up with heating water and bleeding the system

3.4.1 When should you check the operating pressure?

Recently topped-up heating water loses much of its volume in the first few days because it releases gases. This causes air pockets, and the heating system will start to rumble.

- After installing a new heating system, check the operating pressure daily for the first few days. If necessary top up with heating water and bleed the radiators.
- After a while the operating pressure will only need to be checked monthly. If necessary top up with heating water and bleed the radiators.

3.4.2 Checking the operating pressure

The heating contractor will have set the red needle on the pressure gauge to the required operating pressure (at least 1 bar overpressure).

You can check the design operating pressure for this heating system on → page 2.

- Check that the pressure gauge needle is within the green field.
- Top up with heating water if the pressure gauge needle is below the green field.

3.4.3 Filling the heating system and checking for leaks

Before commissioning the heating system, check for leaks to prevent problems during operation. Pressurise the heating system to 1.3x bar permissible operating pressure (observe the safety pressure of the safety valve).

On sealed systems the pressure gauge needle (Fig. 6, **item 2**) must be within the green range (Fig. 6, **item 3**). Set the red needle (Fig. 6, **item 1**) on the pressure gauge to the required system pressure.

- Check the system water pressure



CAUTION!

SYSTEM DAMAGE

through over pressure during leak testing. Pressure, control and safety equipment may be damaged through excessive pressure.

- When you carry out a leak test, make sure that no pressure, control or safety equipment is fitted which cannot be isolated from the boiler water chamber.
- Shut off the pressure expansion vessel from the system by closing the cap valve.
- Check the connections and pipework for leaks.
- Open the mixing and shut-off valves on the hot water (primary) side.
- Fill the system via an approved filling link.

Filling the heating system

Filling and refilling of the heating circuit must be carried out by a method that has been approved by the Water Regulation Advisory Scheme (WRAS), for the type of heating appliances, i.e. Domestic (in-house) Fluid Category 3. Non-Domestic (other than in-house) Fluid Category 4. Depending on the Fluid Category the approved method should comprise of the following:

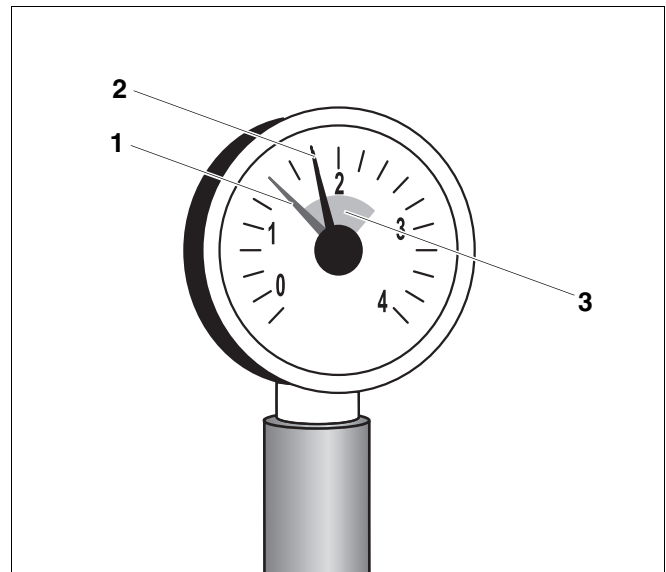

Fig. 6 Pressure gauge for sealed systems

- 1 Red needle
- 2 Pressure gauge needle
- 3 Green field

1. Requirements Fluid Category 3 systems (fig see right)
 - Control valve (stop valve) including a double check valve on the mains cold water supply pipe
 - Temporary connection to be removed after filling (filling loop)
 - Control valve (stop valve) on the heating system pipework

2. Requirements Fluid Category 4 systems (fig see right)
 - Control valve (stop valve) on the mains cold water supply pipe
 - Strainer
 - Verifiable Backflow Prevention Device with reduced pressure Zone (RPZ valve assembly) incorporating a Type BA air gap
 - Tundish
 - Control valve (stop valve) on the heating system pipework

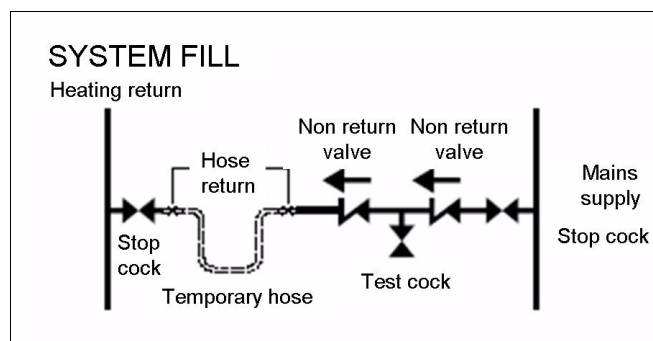

Fig. 7 Requirements Fluid Category 3 systems

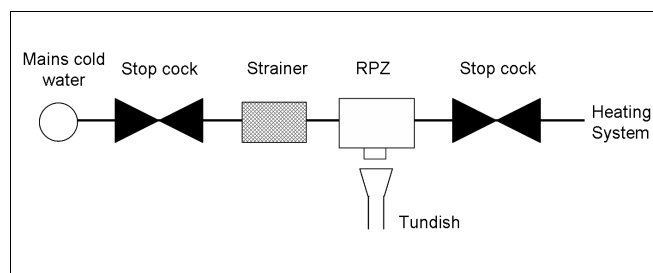

Fig. 8 Requirements Fluid Category 4 systems

- Open the cap of the automatic air vent by one full turn to allow air to escape.
- Slowly fill the heating system. Observe the pressure gauge whilst filling.
- Close the water tap and the boiler drain valve once the required operating pressure has been reached.
- Bleed the system via the radiator bleed valves.
- Top up with water if the pressure drops as a result of bleeding the system.
- Take the hose off the boiler drain valve.



SYSTEM DAMAGE

through frequent topping up.

CAUTION!

The heating system may be damaged, depending on water quality, by corrosion or scaling if you frequently need to top-up the heating water.

- Enquire from your installer, whether you can use your public water untreated or whether you need to treat it before filling your system.
- Notify your installer, if you need to regularly add top-up water to your system.

Correct fuel

This heating system requires fuel of the correct type and grade to ensure its proper operation.

**CAUTION!****SYSTEM DAMAGE**

through incorrect fuel.

- Only use the fuel specified.

Follow the advice of your installer if you want to convert your heating system to another type of fuel or use fuel with a different specification.

Boiler room**CAUTION!****BOILER DAMAGE**

through contaminated combustion air.

- Never use chlorinated cleaning agents or halogenated hydrocarbons (as, for example, contained in spray cans, solvents or cleaning agents, paints and adhesives).
- Avoid very dusty atmospheres.

**CAUTION!****SYSTEM DAMAGE**

through water.

- In case of an acute risk of flooding, disconnect the boiler from its power supply and shut off the fuel supply before water enters the boiler room (→ Chapter 3.2, page 7).
- After the flood has subsided, ask your local installer to check the heating system before starting it up again.
- Ask your installer to replace any valves and control/regulating equipment that have come into contact with water.

3.5 Why is regular maintenance important?

Heating systems should be regularly maintained for the following reasons:

- to achieve a high level of efficiency and to operate the system economically (low fuel consumption),
- to achieve a high level of operational reliability,
- to maintain the cleanest possible combustion.



CAUTION!

SYSTEM DAMAGE

through a lack of, or unsatisfactory, cleaning and maintenance.

- Have your system inspected, cleaned and maintained annually by a heating contractor.
- We recommend you enter into a contract covering an annual inspection and maintenance.

4 Troubleshooting

4.1 Recognising and resetting faults

In the event of a fault, the relevant fault code will flash on the control panel display. The programming unit shows faults as plain text messages.

A fault exists if the display flashes and indicates something other than the current boiler water temperature or an operating message.

Example: "6A" = burner does not start

- Press and hold down the "Reset" button for approx. 5 seconds to clear the fault.

The display shows "rE" whilst the reset is implemented. A reset is only possible if a fault message is flashing.

The fault is cleared when the display shows the standard operating message again. Should the fault recur, repeat the reset two or three times.

If a fault cannot be reset:

- Note down the fault message and notify your installer accordingly.



CAUTION!

SYSTEM DAMAGE

through frost.

The heating system can freeze up in cold weather if it has been switched OFF through a fault shutdown.

- Immediately rectify the fault and restart the heating system.
- If this is not possible, protect your heating system against freezing by draining the central heating and DHW pipework at the lowest possible point.

More information about possible faults can be found in the → control panel documentation.

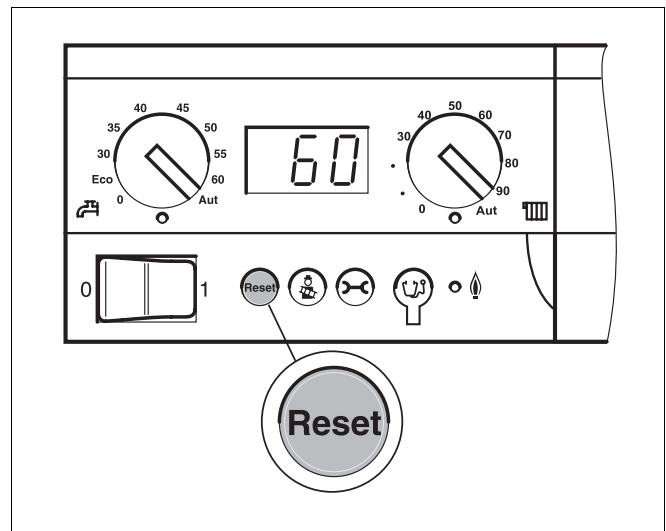

Fig. 9 Clear the fault by pressing the "Reset" button



Your installer:



Buderus

Buderus
Cotswold Way, Warndon, Worcester WR4 9SW
Tel.: 01905 752936, Fax: 01905 753130
www.buderus-commercial.co.uk

BBT Thermotechnik GmbH
D-35573 Wetzlar
www.heiztechnik.buderus.de
info@heiztechnik.buderus.de

In the UK, Buderus is a trading name of
BBT Thermotechnology Ltd.