

Cascade pipework Logano plus GB312 (Dual boiler)

For contractors

Please read carefully prior
to installation and
maintenance.

1	Positioning	3
2	Standard delivery	5
3	Installing the pipework	6
3.1	Installing the pipe connections	6
3.2	Fitting part 1 of the flow connection to the first boiler	7
3.3	Fitting part 2 of the flow connection to the second boiler	7
3.4	Connecting shut-off valves	8
3.5	Installing the return connection	9
3.5.1	Fitting short return piece to the first boiler	9
3.5.2	Fitting part 1 of the long return piece to the second boiler	9
3.5.3	Connecting pumps	10
3.5.4	Welding part 2 of the long return piece.	10
4	Making electrical connection to system and filling	11
4.1	Electrical connection of the system	11
4.2	Filling the system	11

About these instructions

These installation instructions contain important information for the safe and appropriate installation of the cascade pipework.

These installation instructions are designed for heating contractors who, through their training and experience, are accustomed to working with heating systems.

Only use original Buderus spare parts. Losses caused by the use of parts not supplied by Buderus are excluded from the Buderus warranty.

Correct use

The cascade pipework is designed for connecting the water side of two Logano plus GB312 boilers.



USER INFORMATION

Observe all standards and guidelines applicable to the installation and operation of this heating system in your country.

1 Positioning

CAUTION! **SYSTEM DAMAGE**
 from frost.
 Install the boiler in a room free from the risk of frost.

USER INFORMATION
 The pipework for the two boiler blocks should be installed before fitting the flue pipe.

The cascade pipework can be installed in the opposite direction. Please observe the minimum clearances. Reducing the clearances to the minimum makes the boiler more difficult to access.

The base or foundation on which the boiler is to stand must be perfectly flat, level and strong enough to support the weight.

Level the boilers horizontally and vertically.

Boiler rating kW:		180*	240*	320*	400*	480*	560*
A (mm)	Recommended	700					
	Minimum	500					
B (mm)	Recommended	700					
	Minimum	500					
C (mm)	Recommended	500					
	Minimum	100					
D (mm)	Recommended	700			900		
	Minimum	550	550	500	700	650	600
E (mm)		see Fig. 2 and Tab. 2					

Tab. 1 Dimensions (in mm)

* Values of both dual boilers added together

USER INFORMATION
 Where appropriate, allow extra wall clearances for additional components.
 Observe the boiler installation and maintenance instructions.

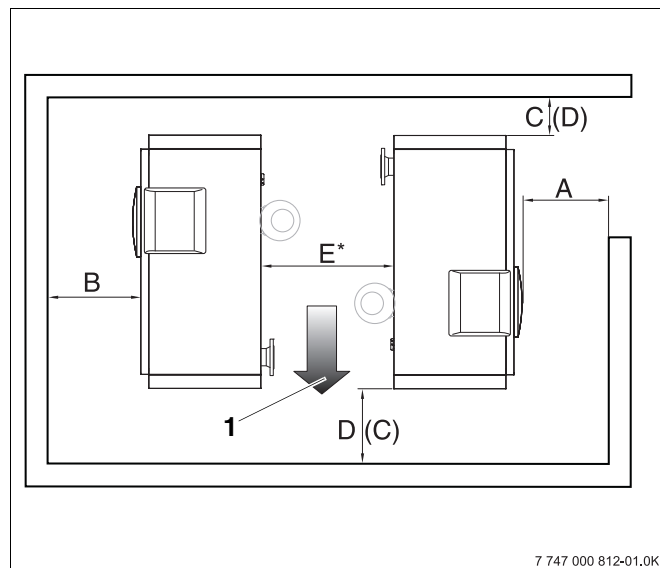

Fig. 1 Positioning

1 Example of pipework direction

() The information in brackets applies when the pipework is installed in the opposite direction.

* See Fig. 2 and Tab. 2.

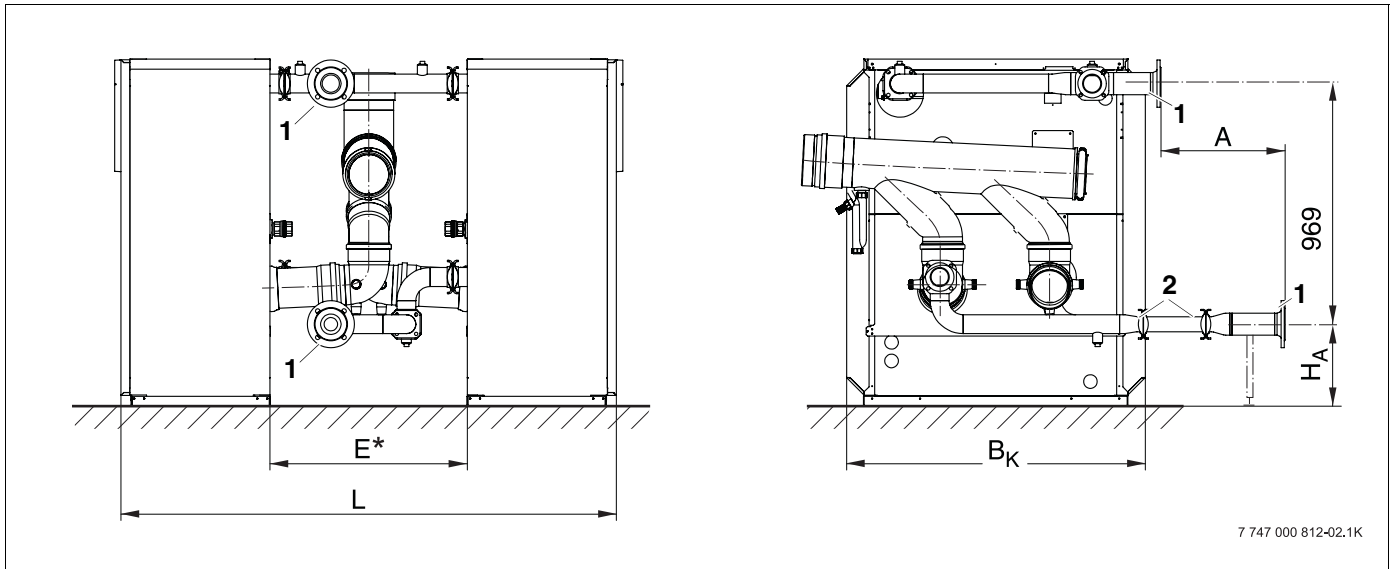

Fig. 2 Cascade pipework dimensions - GB312

* When installing shut-off valves (available as option) for 90 to 120 kW, E is longer by + 108 mm and for 160 to 280 kW, E is longer by + 138 mm.

Dimension A = 560 when installing a pump



USER INFORMATION

Observe that dimension E is greater when fitting additional shut-off valves into the flow VK and return RK (see dimension E* in Fig. 2).

Boiler size	2 x 90 kW (2 x 4 Gld.)	2 x 120 kW (2 x 4 Gld.)	2 x 160 kW (2 x 5 Gld.)	2 x 200 kW (2 x 6 Gld.)	2 x 240 kW (2 x 7 Gld.)	2 x 280 kW (2 x 8 Gld.)
E	642 (750)*	642 (750)*	795 (933)*	935 (1073)*	935 (1073)*	935 (1073)*
L	1842	1842	1995	2135	2135	2135
B _K	994		1202		1410	
H _A	339		330		330	
Flange VK/RK (Fig. 2, [1])	DN65 (hole circle Ø 130)		DN80 (hole circle Ø 150)		DN100 (hole circle Ø 170)	
Pump flange (Fig. 2, [2])	DN50 (hole circle Ø 110)		DN50 (hole circle Ø 110)		DN65 (hole circle Ø 130)	

Tab. 2 GB312 cascade pipework dimensions (in mm)

* Observe the dimension in brackets when installing shut-off valves (available as option) (see also Fig. 2).

2 Standard delivery

The boiler and control unit are installed as described in the installation instructions supplied with the individual products. Order the pumps separately.

Material	Number [pce.]	Fig. 3 Item
Installation instructions		
Flow piece (in two parts)	1	1.1 1.2
Long return piece (in two parts)	1	2.1 2.2
Short return piece	1	3
Return connection piece	1	4
Brace	1	5

Tab. 3 Pipework standard delivery

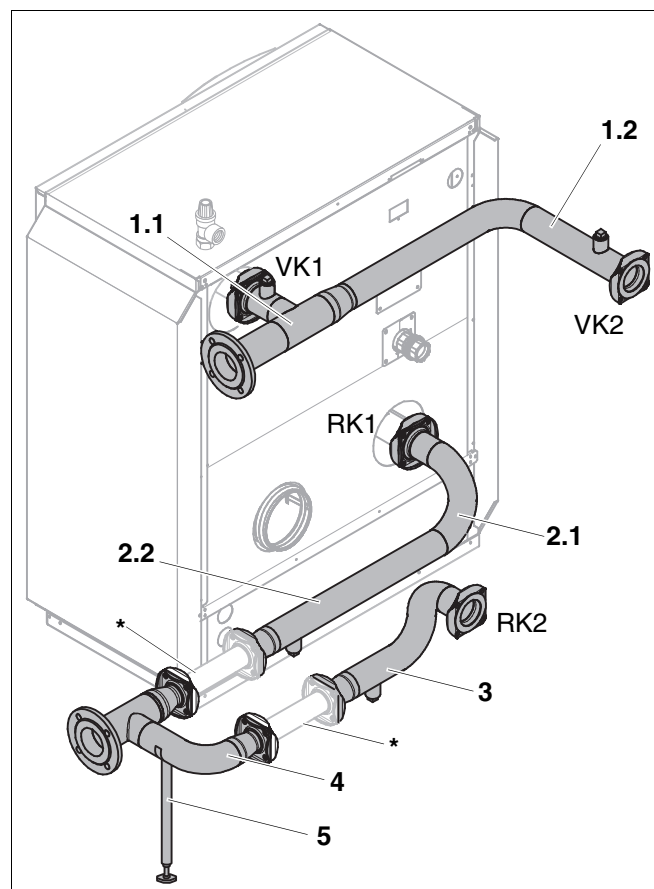



Fig. 3 Pipework standard delivery

* The pipe section shown here is not part of the standard delivery. It is shown in place of the pump.

3 Installing the pipework

Welding work suggests that the cascade pipework on the heating water side should be installed before installing the flue gas header.

 CAUTION!	SYSTEM DAMAGE through incorrect installation or operation.
	Observe the installation and maintenance instructions plus the boiler operating instructions.

3.1 Installing the pipe connections

	USER INFORMATION Only make connections in the positions shown in Fig. 4.
--	--

- Before installing the pipe connections, check connections on the boiler for possible damage.

	USER INFORMATION If one of the flanged connectors becomes loose after installation/commissioning, a new gasket should be inserted before tightening again.
--	--

 CAUTION!	SYSTEM DAMAGE from leaking connections.
	Tighten screws and nuts on flanged connectors diagonally.

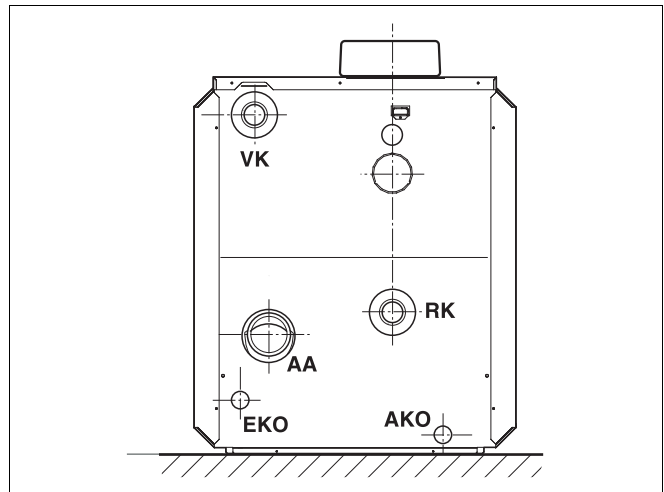



Fig. 4 Logano GB312 boiler connections

- Legend for Fig. 4*
- AA = Flue outlet
 - VK = Boiler flow
 - AKO = Condensate outlet
 - RK = Boiler return
 - EKO = Condensate inlet

3.2 Fitting part 1 of the flow connection to the first boiler

- Remove the factory-fitted welded flange from the flow.

CAUTION!  **SYSTEM DAMAGE**
Hold the check valve firmly when removing the welded flange.

- The check valve (Fig. 5, [5]) remains fitted to the flow according to the flow direction.

CAUTION!  **SYSTEM DAMAGE**
through incorrect installation.
CAUTION! Note the flow direction of the check valve. The valve must open in the direction of flow.

- Place gasket (Fig. 5, [2]) on the check valve.
- Secure flow piece flange (Fig. 5, [6]) to flow flange (Fig. 5, [4]) on the boiler using four bolts (Fig. 5, [3]) and nuts (Fig. 5, [1]).

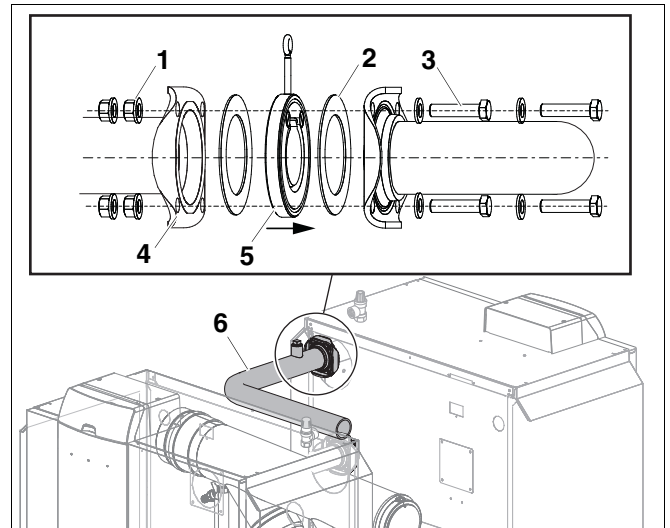



Fig. 5 Fitting the flow connection to the first boiler

- 1 Nut (boiler standard delivery)
- 2 Gasket (boiler standard delivery)
- 3 Bolt (boiler standard delivery)
- 4 Flange on boiler flow
- 5 Check valve (boiler standard delivery)
- 6 Flow piece (part 1)

3.3 Fitting part 2 of the flow connection to the second boiler

- Remove the factory-fitted welded flange from the flow.

CAUTION!  **SYSTEM DAMAGE**
Hold the check valve firmly when removing the welded flange.

- The check valve (Fig. 6, [5]) remains fitted to the flow according to the flow direction.

CAUTION!  **SYSTEM DAMAGE**
through incorrect installation.
CAUTION! Note the flow direction of the check valve. The valve must open in the direction of flow.

- Place gasket (Fig. 6, [2]) on the check valve.
- Secure flow piece flange (Fig. 6, [6]) to flow flange (Fig. 6, [4]) on the second boiler using four bolts (Fig. 6, [3]) and nuts (Fig. 6, [1]).

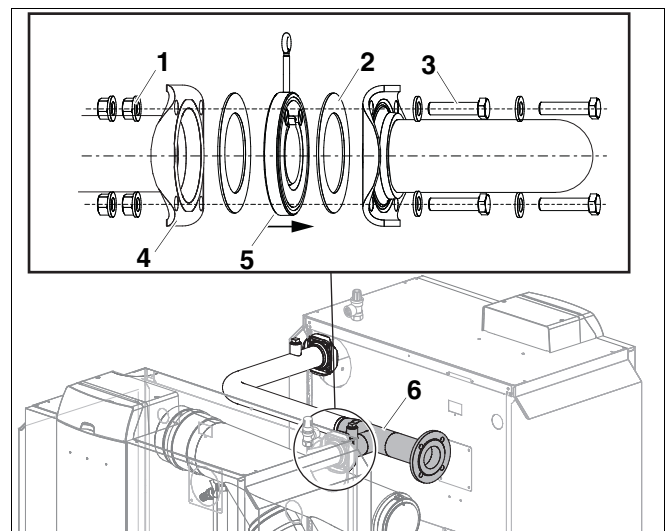

Fig. 6 Fitting flow piece onto the second boiler

- 1 Nut (boiler standard delivery)
- 2 Gasket (boiler standard delivery)
- 3 Bolt (boiler standard delivery)
- 4 Flange on boiler flow
- 5 Check valve (boiler standard delivery)
- 6 Flow piece (part 2)

- Weld the two flow pieces together without applying any stress.



USER INFORMATION

Because of tolerances, the pipe sections may have to be adjusted. Trim the pipe sections if required or bend at the elbow by warming.

Fem. connections on flow connection (Fig. 7, [1]) are provided for venting.

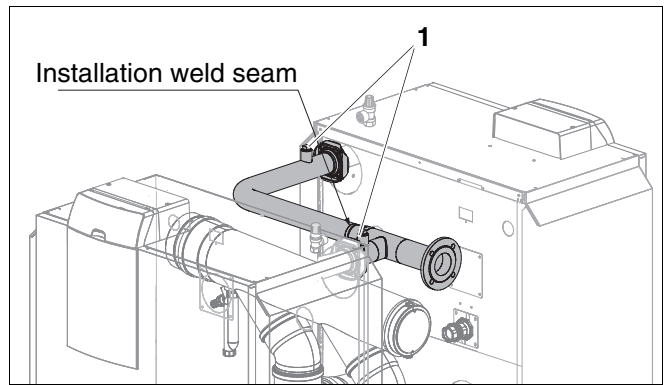

Fig. 7 Welding flow connection

3.4 Connecting shut-off valves

Shut-off valves (Fig. 8, [1]) are not part of the standard delivery and must be ordered separately. One shut-off valve can be connected to each flow and return.



USER INFORMATION

The check valve is not required if the shut-off valve is fitted in the return.



USER INFORMATION

The loosely fitted flange in the boiler connection is not required.

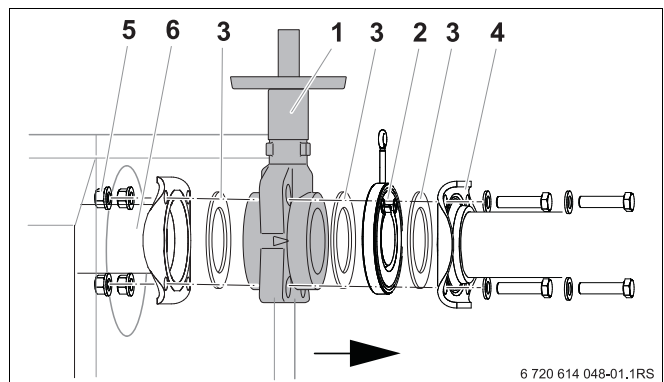

Fig. 8 Installing shut-off valve

- 1 Shut-off valve
- 2 Check valve
- 3 Gasket
- 4 Flow piece of cascade pipework
- 5 Nut
- 6 Boiler flow with flange, welded to the boiler

CAUTION! **SYSTEM DAMAGE**

Hold the check valve firmly when removing the welded flange.

Use the additional gasket and longer bolts for the installation of the shut-off valves.

- Remove the loose flange and check valve from the boiler connection.
- Place gasket (Fig. 8, [3]) and shut-off valve (Fig. 8, [1]) on the boiler flange.
- Place gasket (Fig. 8, [3]), check valve (Fig. 8, [2]) and gasket (Fig. 8, [3]) on shut-off valve (Fig. 8, [1]).
- Secure flow piece flange (Fig. 8, [4]) on boiler flow flange using four bolts and nuts (Fig. 4, [5]).

When fitting shut-off valves, extend the flue pipe from the flue gas connection on the boiler using the pipe supplied.

- Trim the pipe to dimension 108 mm for 90 to 120 kW or to 138 mm for 160 to 280 kW boilers.
- Insert the pipe at the boiler flue gas connection (see "Flue gas header installation instructions").

3.5 Installing the return connection

3.5.1 Fitting short return piece to the first boiler

- Remove the factory-fitted welded flange from the return.
- Place gasket (Fig. 9, [2]) on the boiler return.
- Secure return piece flange (Fig. 9, [5]) to boiler return flange (Fig. 9, [4]) using four bolts (Fig. 9, [3]) and nuts (Fig. 9, [1]) and tighten by hand.

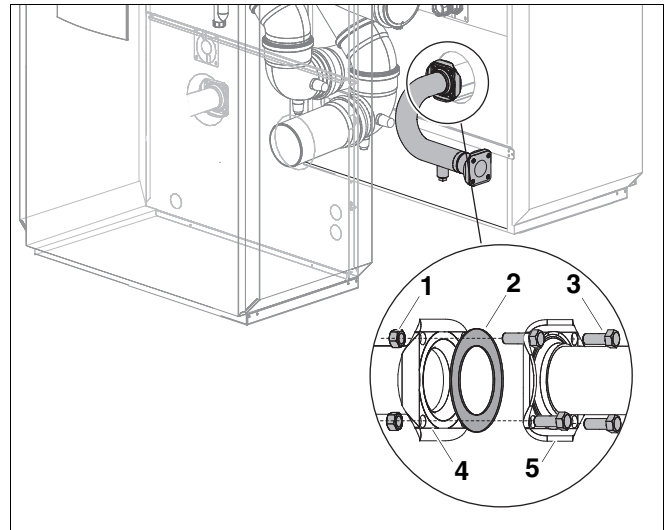

Fig. 9 Fitting the return connection to the first boiler

- 1 Nut (boiler standard delivery)
- 2 Gasket (boiler standard delivery)
- 3 Bolt (boiler standard delivery)
- 4 Flange on boiler return
- 5 Return piece

3.5.2 Fitting part 1 of the long return piece to the second boiler

- Remove the factory-fitted welded flange from the return.
- Place gasket (Fig. 10, [2]) on the return of the second boiler.
- Secure return piece flange (Fig. 10, [5]) to return flange (Fig. 10, [4]) of the second boiler using four bolts (Fig. 10, [3]) and nuts (Fig. 10, [1]).

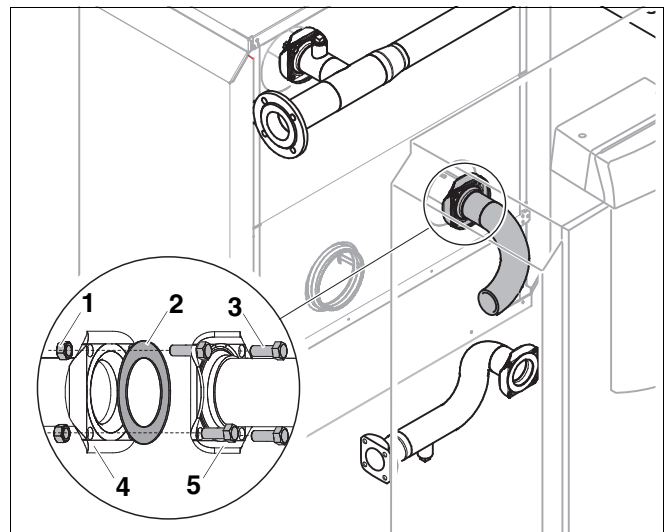



Fig. 10 Fitting return piece to the second boiler

- 1 Nut (boiler standard delivery)
- 2 Gasket (boiler standard delivery)
- 3 Bolt (boiler standard delivery)
- 4 Flange on boiler return
- 5 Return piece

3.5.3 Connecting pumps

The pumps (heating circuit pumps) (Fig. 11, [1]) are not part of the standard delivery and must be ordered separately.

Use two pumps, subject to the system layout. For this, observe the recommended system circuits from the technical guide (e.g. use of one pump (heating circuit pump) when using a low loss header).

 CAUTION!	SYSTEM DAMAGE
	through fitting pump incorrectly. ● Always fit the pump and motor horizontally between the flange.

Gasket and bolts do not form part of the standard delivery of the pipework (available as option).

- Position pump with gasket in flow direction on the return piece flange and secure with four bolts and nuts.
- Secure return connecting piece (Fig. 12, [2]) with gasket to pump (Fig. 12, [1]) using four bolts and nuts, as shown in Fig. 12.
- Position brace (Fig. 12, [3]) under the return connecting piece and adjust its height until the return pipework is stress-free.
- Place the second pump (according to the flow direction) with gasket on the flange of the return connecting piece and fasten using 4 bolts and nuts.
- Place the flange of part 2 of the long return piece (Fig. 13, [2]) with gasket on the second pump and secure using four bolts and nuts.
- Tighten screws on the flanged connections.

3.5.4 Welding part 2 of the long return piece

- Weld both parts of the long return piece together without applying any stress.
- Check all connections and weld seams for leaks.

	USER INFORMATION
	Because of tolerances, the pipe sections may have to be adjusted. Trim the pipe sections if required or bend at the elbow by warming.

The fem. connection on the return connection (Fig. 13, [3]) is provided for draining.

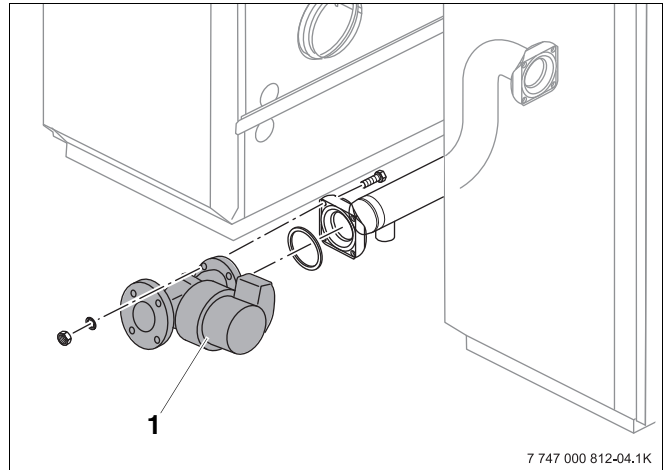

Fig. 11 Connecting the pump

- 1 Pump (available as option)

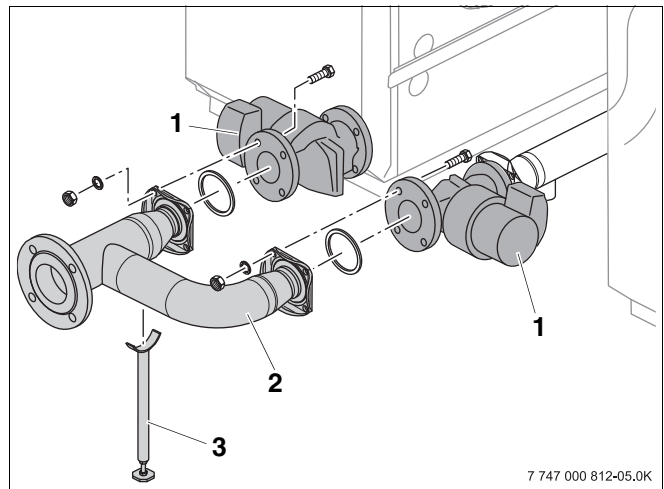

Fig. 12 Fitting return connecting piece

- 1 Pump
 2 Return connecting piece
 3 Brace

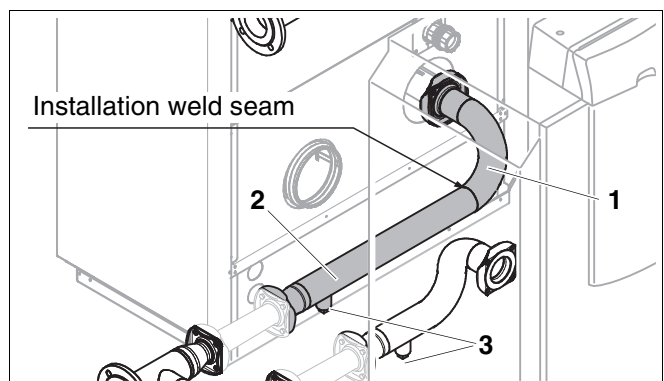



Fig. 13 Welding the long return piece

- 1 Part 1 of the long return piece
 2 Part 2 of the long return piece
 3 Fem. connection on the return

4 Making electrical connection to system and filling

4.1 Electrical connection of the system

	RISK TO LIFE from electricity.
WARNING!	<ul style="list-style-type: none">● Ensure that the electrical cables are not touching any hot parts.

- The electrical connections must be carried out as per the wiring diagram according to the technical documentation for the control unit.

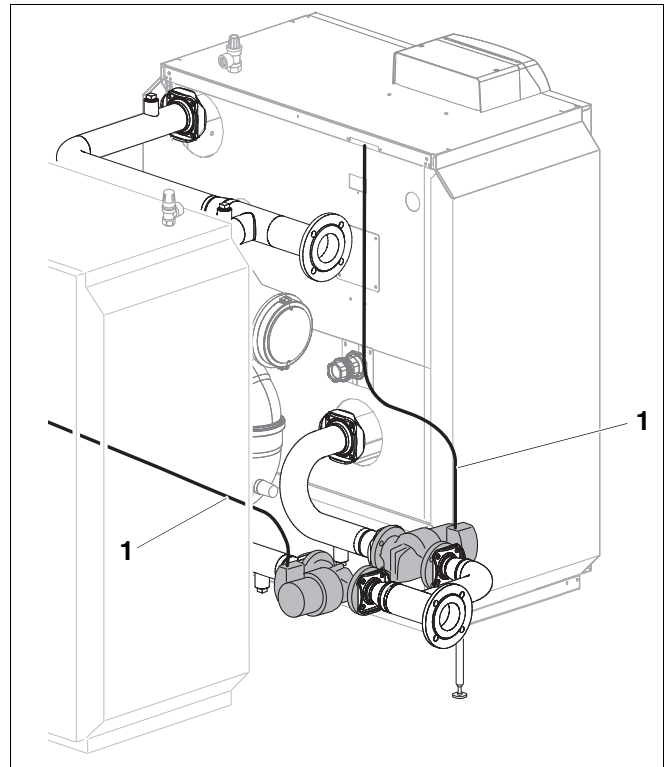

Fig. 14 Electrical connection

1 Electrical cables for pumps

4.2 Filling the system

Observe the installation and maintenance instructions of the boiler.

Buderus
Cotswold Way, Warndon, Worcester WR4 9SW
Customer service: 0870 421 5933
Technical support: 0870 421 5944
Fax: 01905 753130
www.buderus.co.uk

In the UK and IE, Buderus is a brand name of
Bosch Thermotechnology Ltd.

Buderus