

Installation Instructions

Alpha SolarSmart Flat Roof Mounting Kit

(Part No. 6.4000800)

Only for use with SolarSmart Landscape Collector

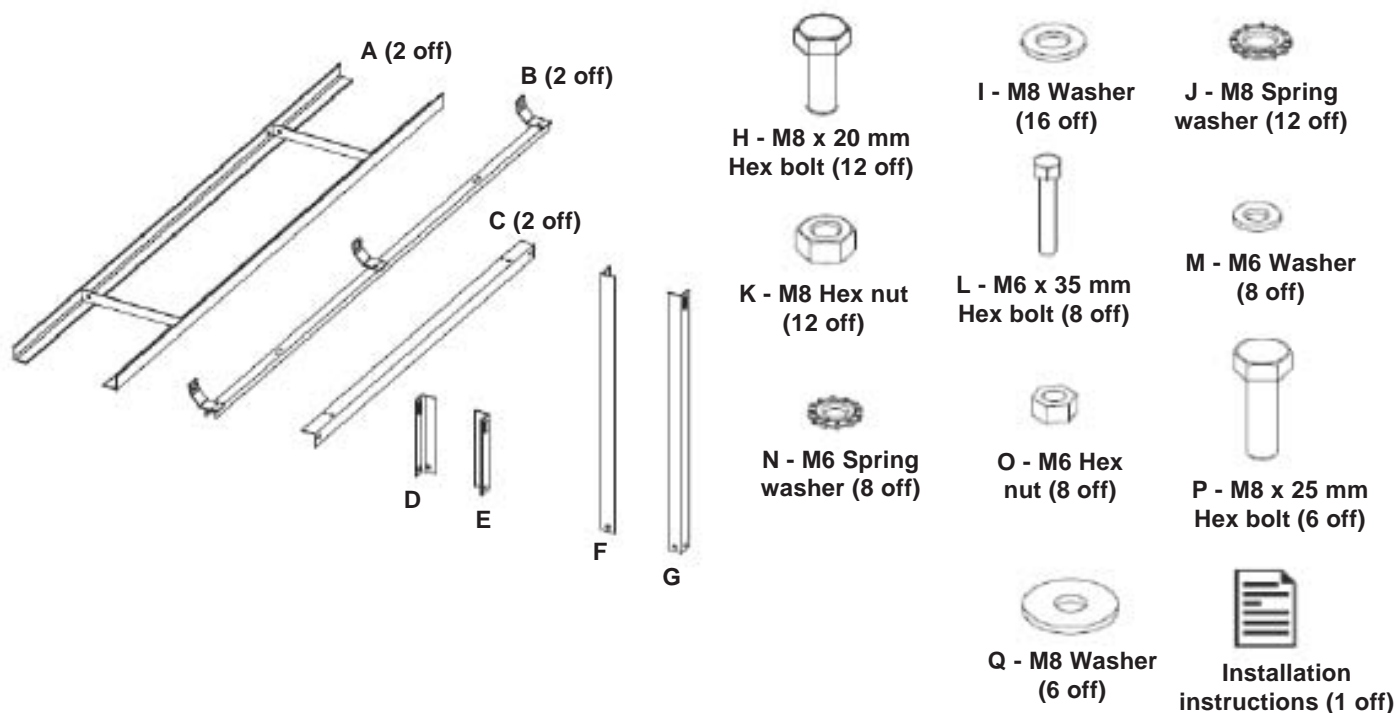

Fig. 1 Kit Contents

1. INTRODUCTION

The flat roof frame has been designed to be free standing on a flat roof, so as not to damage the integrity of the roof surface. The frame is secured in position by placing weight on the frame using 30 x 30 cm concrete paving slabs/tiles. See Section 2, paragraph e) for the approximate weights of standard slabs/tiles. When positioning the frame, you need to take into account **all** the important notes detailed below:-

Important Notes: -

- To obtain the highest efficiency from the collector, place the collector as near to south facing as possible, at least between South East and South West.
- The flat roof **must** be strong enough to withstand the total weight that will be placed on the frame to secure it against the maximum wind gusts for the location in which the collector is being installed. Refer to Section 3.
- If the the wind speed for the location of the installation is higher than 25 metre per second or falls into the 'grey' area of the table in Section 3, then the frame **must not** be fitted on the flat roof.
- Avoid positions where objects may cast shadows on the collector.
- Place the collector as close as possible to the drain back unit (DBU). The maximum height from the bottom of the DBU to the top of the collector is 3 metres, do not use more than 2 metres of pipe for each of the flow and return between the DBU and collector. The DBU must always be positioned lower than the collector.
- Both the flow and return pipes from the collector to the DBU must be mounted with a minimum slope of 40 mm per metre. Ensure that the flexible pipework is also mounted with a slope to the DBU.
- The flow and return pipes must be insulated with high temperature insulation, i.e. 150°C plus.
- The collector must always be level. The frame offers some adjustment by the slotted holes in the vertical supports, see frame 4 in Fig. 2.
- Place some extra roofing material on the location where the Flat Roof frame will be placed to protect the surface of the roof.
- Ensure that the slabs/tiles are positioned on each corner and inside the channels of the frame. Ensure that the correct amount of weight is placed on the frame. Refer to Section 3.

2. INSTALLATION

a) Assemble the frame as shown in 1, 2, 3, and 4.

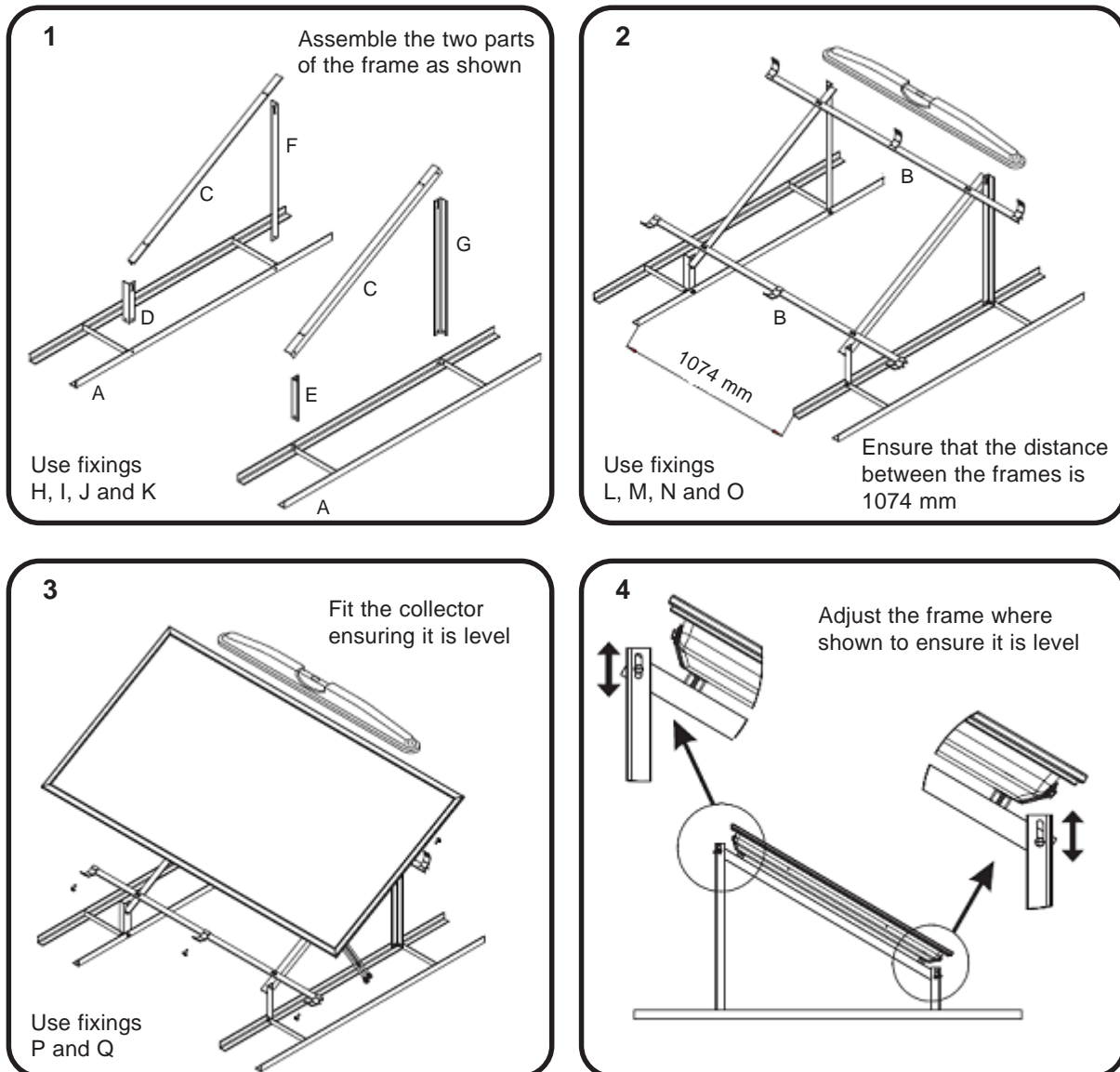

Fig. 2

b) Refer to Section 1 and position the collector and frame on the roof facing South and as close as possible to the drain back unit.

- Notes:** i) Place extra roofing material where the frame is to be positioned to protect the roof.
ii) Check that the roof is strong enough to withstand the total weight of the frame, collector and slabs/tiles.

c) Refer to Section 1 and connect the pipework to the drain back unit as described in the instructions supplied with the SolarSmart pack.

- Note:** Ensure that the pipes are insulated with the high temperature insulation supplied. If more is required, this is available from your local plumbing merchant.

d) Refer to the map, Fig. 3, and table, to determine the amount of weight required to place on the frame to secure it in position.

e) When determined, position the required number of slabs/tiles inside the channels at each corner of the frame.

- Note:** 300 mm x 300 mm concrete paving slabs/tiles fit into the channels. Slabs/tiles are available from your local building merchant.

e.g. A 300 mm x 300 mm x 50 mm thick tile weighs 11 kg.

3. DETERMINE THE WEIGHT TO BE PLACED ON FRAME

To determine the weight to be placed onto the frame refer to the table below.

IMPORTANT: Ensure that the weight is evenly distributed and is placed inside the channels on each corner.

Note: To determine your altitude above sea level, refer to www.ordnancesurvey.co.uk

Topography not significant		Altitude 0 to 100 m	Altitude 100 to 200 m	Altitude 200 to 300 m
Zone (see map below)	Building height (m)	Total weight to be placed on frame (kg)	Total weight to be placed on frame (kg)	Total weight to be placed on frame (kg)
I	5	318	386	458
	10	376	454	540
	15	410	494	586
II	5	388	470	
	10	458	554	
	15	498		'Grey Area'
III	5	466	562	DO NOT use flat roof kit
	10	548		
	15	596		

Note: If the topography is significant and the wind speed for the location of the installation is higher than 25 metre per second, then the frame must not be fitted on the flat roof. For further information refer to the BRE document Digest 489 - Wind Loads on Roof - Based Systems, available at www.bre.co.uk

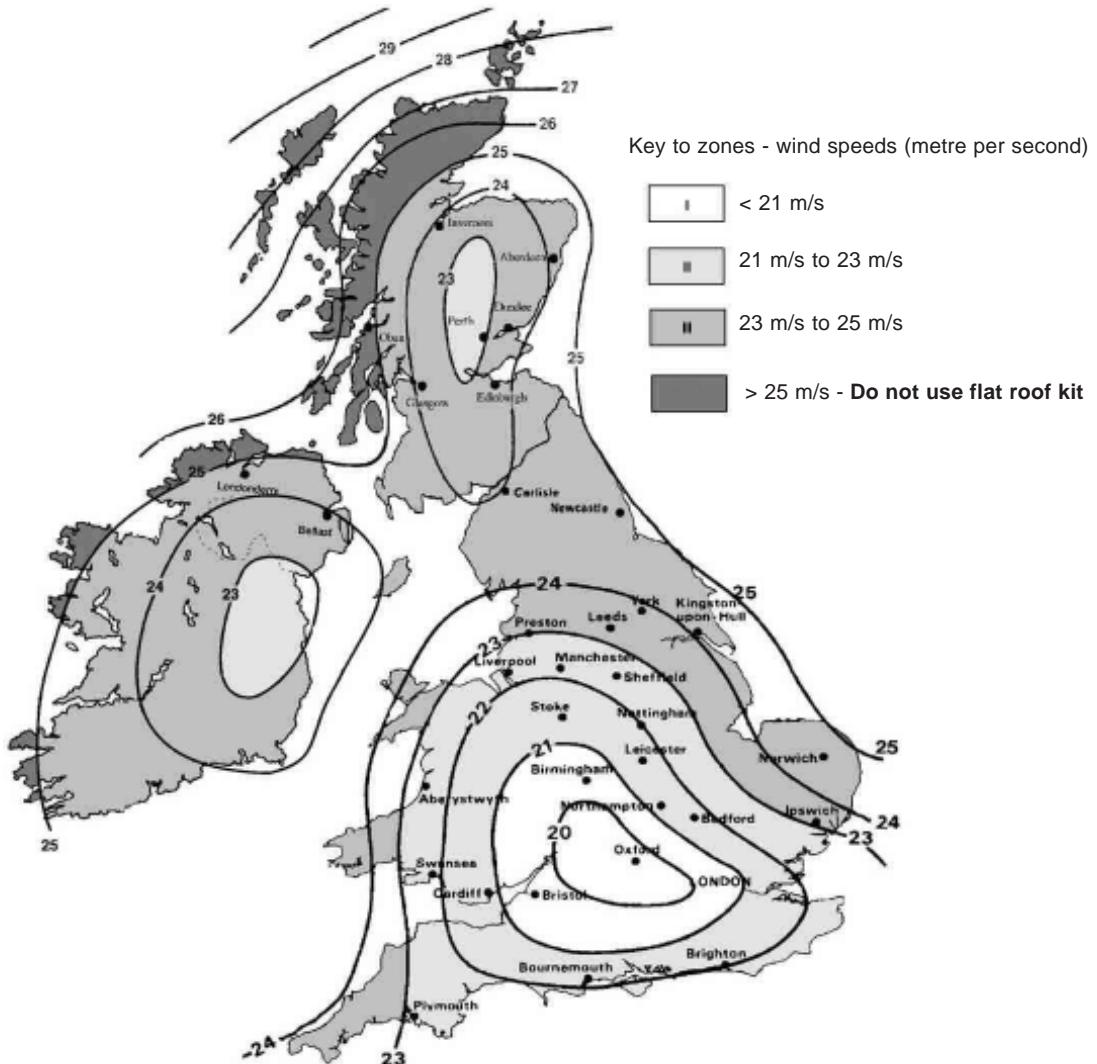

Fig. 3 - Map of UK wind speed zones

Map reproduced from Digest 489 with permission of BRE



Alpha Therm Limited.
Nepicar House, London Road, Wrotham Heath,
Sevenoaks, Kent TN15 7RS
Tel: 0870 3001964

email: info@alphatherm.co.uk
website: www.alpha-boilers.com

These instructions have been carefully prepared but we reserve the right to alter the specification at any time in the interest of product improvement.
© Alpha Therm Limited 2006.