

MagnaClean[®]

TwinTech

Dual-action system protection



NEW
magnetic AND
non-magnetic
technology

Improves system performance and energy efficiency
using advanced *MagnaClean* technology

ADEY

PROFESSIONAL HEATING SOLUTIONS

MagnaClean®

TwinTech

Powerful dual-action magnetic and non-magnetic filtration

MagnaClean TwinTech® sets the industry standard in the delivery of guaranteed central heating system maintenance and protection.

ADEY's MagnaClean technology has evolved to become the professional plumbing and heating engineers' choice throughout the sector. Advances in recent years have now created a totally effective all-in-one filter, eliminating virtually 100% of suspended black iron oxide and all other non-magnetic particles and debris from the system.

Immediate benefits

MagnaClean TwinTech is a proven technology and with its powerful magnetic and non-magnetic filtration characteristics, the benefits for new and existing central heating systems are immediate:

- **Powerful magnetic filtration**
- **Exceptional non-magnetic filtration**
- **Simple installation and servicing, saving time and money**
- **Quick and easy chemical dosing**
- **Increased energy efficiency**
- **Longer central heating system life**
- **Guaranteed for two years**

In an age of advanced and high efficiency gas and oil boilers, there has never been a greater need to maintain and safeguard one of the most expensive investments in the modern home.

Even a small build-up of sludge, debris or deposits in a standard or modern efficiency boiler results in poor performance; substantial efficiency loss; fuel wastage; cold spots; noisy operation; breakdown and escalating maintenance costs. The oxide particles range from large to sub-micron with the latter leeching into the system water continuously during use.

The particles such as water hardness scales, iron oxide flakes, casting sand, welding debris, non-ferrous metal flakes and other unwanted materials, bond to all components causing premature failure of pumps and valves. When they contaminate the boiler heat exchanger and pipework, dramatic efficiency losses result. Tests have shown that even a minimal build-up results in a serious drop in boiler efficiency.



Years of protection

The dual combination of MagnaClean TwinTech's high performance magnetic filter and advanced fine wire gauze eliminates both the metallic-based sludge and debris along with the non-magnetic particles, debris and scale.

MagnaClean TwinTech provides many years of protection, maintaining the high operational efficiency of the heating system, resulting in financial benefit and increased reliability. It is also backed by a two year limited guarantee.



Technical specifications

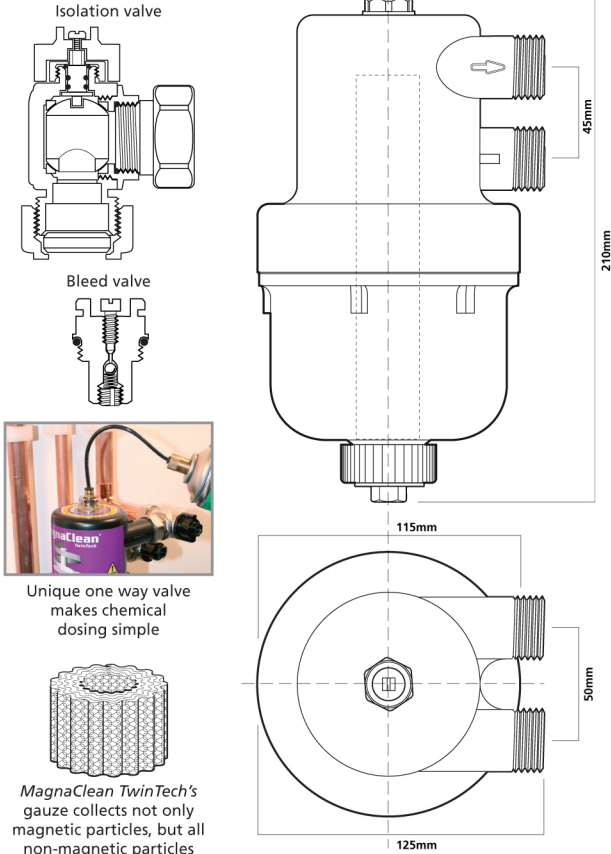

Unique one way valve makes chemical dosing simple

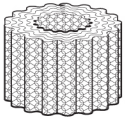

MagnaClean TwinTech's gauze collects not only magnetic particles, but all non-magnetic particles

Below are the five options for easy installation of MagnaClean TwinTech. For further information please refer to the Installation and Servicing leaflet.



Our recommendation is to fit a MagnaClean filter on every new central heating installation on the basis that prevention is better than cure. The benefits to your customer are tangible – A more effective central heating system and longer operational life; improved energy efficiency and reduced maintenance bills.

To deliver a more powerful and guaranteed central heating system solution, ask your supplier about *MagnaClean TwinTech* TODAY, or call 01242 546700 NOW

How it works in seconds!



Magnetic and non-magnetic debris are deposited in a container...



The *MagnaClean TwinTech* dual-action filter is placed into the container...



Within seconds the water starts to clear as *MagnaClean TwinTech* sets to work...



After just ten seconds, virtually all debris has been trapped and the water is clear...



The *MagnaClean TwinTech* magnet and gauze filter is removed for easy cleaning.

For more information or to see this step by step demonstration, visit

www.adeysolutions.co.uk

MagnaClean®

TwinTech

MagnaClean TwinTech – Our word on it...

"MagnaClean technology has been developed to meet a need in the professional heating and plumbing sector. Having listened carefully to the market, we've taken the technology to the next level and believe MagnaClean TwinTech delivers the best energy efficient performance available to the industry. We have yet to find an installer or customer who has not been surprised and impressed by the capabilities of MagnaClean technology."

Chris Adey, Managing Director, ADEY Limited

From an experienced industry professional...

"As a retired plumber, I've dealt with numerous heating systems. I fitted MagnaClean to my central heating system, and WOW! The result is that I now have a quieter, cleaner and more efficient heating system. The radiators get hot from top to bottom and the boiler is now quiet when running. Your product is BRILLIANT! I wish I'd had this filter 15 years ago!"

Jon Chaffey, Christchurch, Dorset

From a satisfied customer...

"Installing MagnaClean has had an instant, positive impact on my central heating system. The newly-installed boiler was proving to be highly inefficient prior to the installation of this 'magic' filter. Once again, thank you for this 'wonder' product."

Homeowner, Finchley, London



Put MagnaClean to work for you today

To discover a more powerful and guaranteed central heating system solution, ask your supplier about MagnaClean TwinTech TODAY or call 01242 546700 NOW



PROFESSIONAL HEATING SOLUTIONS

Telephone 01242 546700 Email: info@adeysolutions.co.uk
www.adeysolutions.co.uk



A carbon neutral company