



condensing &
high efficiency
hot water & heating
products from ACV
a stainless reputation for more than 80 years



excellence in hot water

Contents

Introduction	2
What is Tank-in-Tank Technology?	3
SmartLine SLE	4
SmartLine SL	6
SmartLine SLME	8
Jumbo	10
HeatMaster 35TC–85TC	12
HeatMaster 60	14
HeatMaster 70-100	16
HeatMaster 71–101	18
HeatMaster 200	20
HeatMaster 201	22
HeatMaster 201 Condenser	24
Delta Performance	26
Delta FV/MV	28
Prestige 24–32	30
Prestige 50–75–120	32
E-Tech S	34
E-Tech W	36
E-Tech P	38
Compact A	40
Compact N	42
Flue Systems	44
Balancing Sedimentation Vessels	46



ACV Seneffe, Belgium



Head Office & Distribution, ACV UK



Introduction

ACV UK is a subsidiary of the ACV International Group that has been designing, manufacturing and marketing technological systems for hot water generation since 1922. ACV International was founded in Belgium and pioneered the Tank-in-Tank concept – a cutting edge design providing exceptional performance.

All products are manufactured on two production sites in Belgium and in the USA. Through fourteen subsidiaries and a broad network of specialised distributors, ACV has a presence on all five continents.

Most ACV products are based on the Tank-in-Tank concept. This technology gives our products exceptional performance in hot water and heating generation.

Today, ACV offers innovating products that fulfil all the demands of a modern world, thanks to the advanced exclusive technology; we offer solutions that are reliable, high performing, economical and environmentally friendly.

What is Tank-in-Tank technology?

A simple and effective concept delivering outstanding reliable performance.

The Tank-in-Tank is a DHW tank entirely immersed within an outer tank which contains the primary fluid, with the inner tank itself being a stainless steel heat exchanger. The corrugated wall of the inner tank forms a large heat exchange surface that can heat the domestic water in a very short time. It also provides a uniform temperature throughout the volume of the tank. Since the inner tank can move freely, it can expand and contract under changes in pressure and prevent limescale forming on the surface.

This simple and highly effective design allows specifiers and installers to benefit from the cost advantages of ACV's high volume production while taking comfort from the fact that the system they are specifying or installing is the best available.

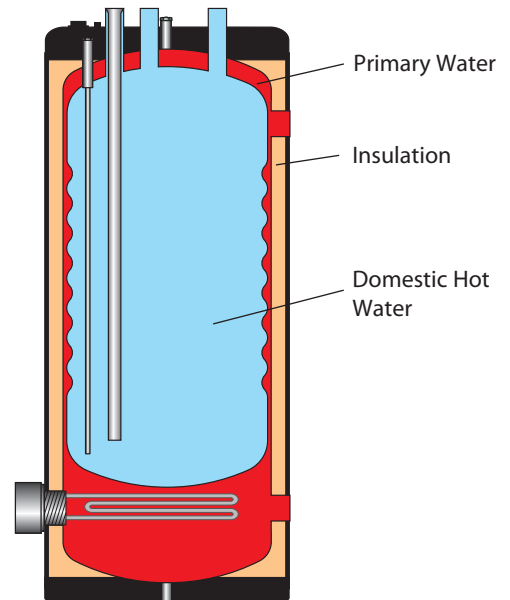

Key Features

- A specially designed stainless steel hot water cylinder enclosed within an outer tank which is heated by the boiler
- The inner tank also acts as a large thermal store, and is surrounded by primary hot water. Recovery is exceptionally fast because the heat transfer surface is so large
- The internal cylinder is designed to operate at up to 10 bar - suitable for any kind of application, mains pressure or vented
- Sides of the cylinder are corrugated which increases the heat transfer area. Expansion and contraction in use shrugs off scale deposits
- Each draw-off causes natural turbulence keeping particles in suspension
- Stainless steel construction means no anode protection, no contamination, leaking or sludging caused by cracked glass linings. Water held at consistently higher temperatures discourages growth of Legionellae bacteria



SmartLine SLE

Fast recovery Tank-in-Tank cylinder – standard 3kW immersion, perfect partner to condensing boiler.

At a time when consumers are demanding higher performance from their hot water installations, the traditional coil based cylinders find it more difficult to deliver high volumes of water for the modern user.

ACV Tank-in-Tank technology represents a significant advance in the science of hot water production. A greater heat transfer surface means Tank-in-Tank units recover much faster than any other type of hot water storage cylinder – keeping boiler cycling to a minimum, and ultimately giving improved fuel efficiency with outstanding hot water delivery.

SmartLine SLE Features:

- 3kW immersion heater in primary
- Stainless steel construction – no anode protection required
- Low heat loss – high quality 50mm polyurethane insulation
- Easy access control pod with thermostats and six-pin plug for simple electrical connection
- Hard wearing polypropylene finish
- Vented or unvented use, mains pressure system supplied
- Failsafe DHW mixing valve
- Can be used in battery formation for higher hot water output



SLE 130

2 Bed House with bath/shower



SLE 160

3 Bed House with bath/shower



SLE 210

4 Bed House with two baths/shower



SLE 240/SLE300

5 Bed House with two baths/two showers

Technical Data

		SLE 130	SLE 160	SLE 210	SLE 240	SLE 300
Total capacity	L	130	161	203	242	293
Primary capacity	L	55	62	77	78	93
Heating surface area	m ²	1.03	1.26	1.54	1.94	2.29
Primary pressure drop	mbar	17	22	37	45	51
Primary flow rate	Ltrs/hr	2100	2600	3500	4200	5500
Maximum useable input from boiler	kW	23	31	39	53	68
Primary connections (female BSP)	Ø	1"	1"	1"	1"	1"
Hot water connections (male BSP)	Ø	3/4"	3/4"	3/4"	3/4"	3/4"
Immersion heater connection (female BSP)	Ø	1 1/2"	1 1/2"	1 1/2"	1 1/2"	1 1/2"
Weight empty	kg	45	54	66	76	87
Weight full	kg	175	215	269	318	380
Maximum operating temperature	°C	85	85	85	85	85

Maximum operating pressure Primary: 3 bar Secondary: 10 bar

Performance Data

		SLE 130	SLE 160	SLE 210	SLE 240	SLE 300
Litres in first 10 minutes	40°C	236	321	406	547	800
Litres in first 10 minutes	45°C	202	275	348	469	640
Litres in first 10 minutes	60°C	117	161	209	272	370
Litres in first hour	40°C	784	1063	1349	1820	2360
Litres in first hour	45°C	672	911	1156	1560	1920
Litres in first hour	60°C	384	549	689	913	1100
Continuous flow 40°C	Ltrs/hr	658	890	1132	1527	2100
Continuous flow 45°C	Ltrs/hr	564	763	970	1309	1710
Continuous flow 60°C	Ltrs/hr	320	465	576	769	970
Initial heat up time 10°C to 85°C	Min	22	22	20	20	22

Please Note: Performance data assumes a primary flow temperature of 85°C and a domestic cold water supply of 10°C

Characteristics

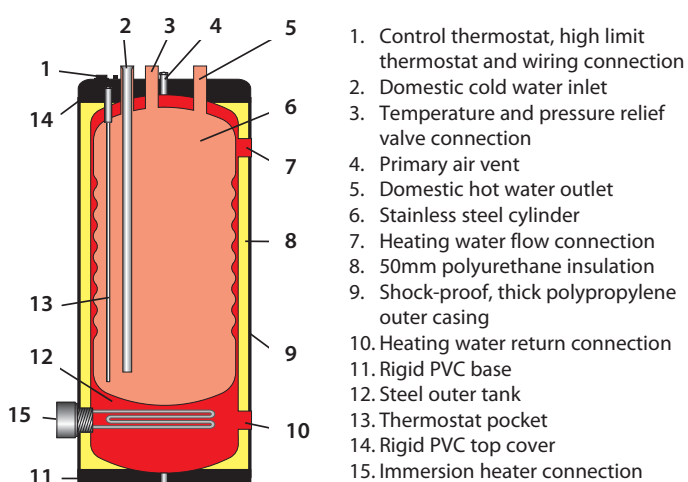

Dimensions

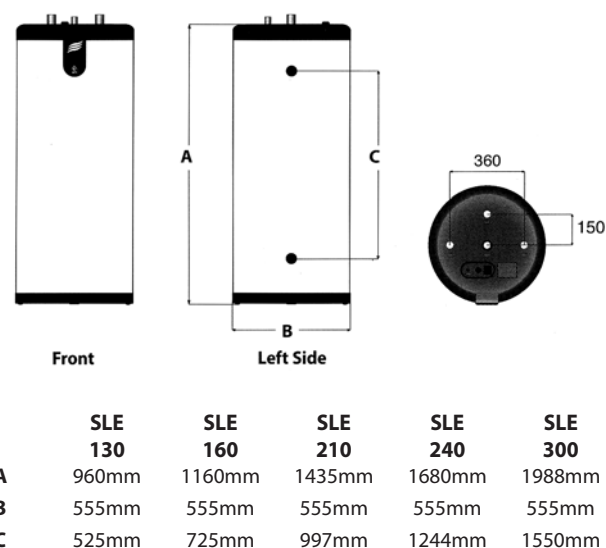

SmartLine SL

Fast recovery Tank-in-Tank cylinder – perfect partner to condensing boiler.

At a time when consumers are demanding higher performance from their hot water installations, the traditional coil based cylinders find it more difficult to deliver high volumes of water for the modern user.

ACV Tank-in-Tank technology represents a significant advance in the science of hot water production. A greater heat transfer surface means Tank-in-Tank units recover much faster than any other type of hot water storage cylinder – keeping boiler cycling to a minimum, and ultimately giving improved fuel efficiency with outstanding hot water delivery.

SmartLine SL Features:

- Stainless steel construction – no anode protection required
- Low heat loss – high quality 50mm polyurethane insulation
- Easy access control pod with thermostats and six-pin plug for simple electrical connection
- Hard wearing polypropylene finish
- Vented or unvented use
- Mains pressure systempak available
- Residential or commercial use
- Can be used in battery formation for higher hot water output

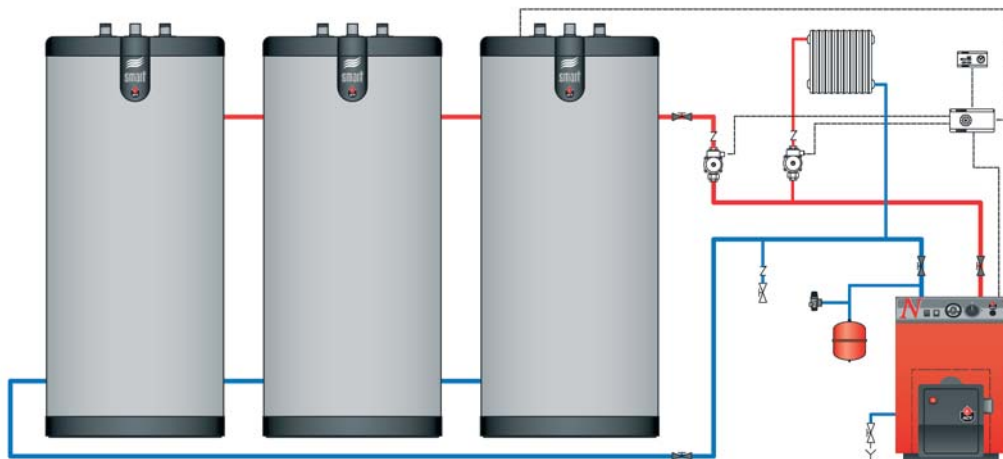

Technical Data

		SL320	SL420	SL600
Total capacity	L	318	413	606
Primary capacity	L	55	55	161
Heating surface area	m ²	2.65	3.24	3.58
Primary pressure drop	mbar	90	95	92
Primary flow rate	Ltrs/hr	6200	6400	7200
Maximum useable input from boiler	kW	73	88	88
Primary connections (female BSP)	Ø	1½"	1½"	2"
Hot water connections (male BSP)	Ø	1½"	1½"	1½"
Weight empty	kg	141	167	238
Weight full	kg	459	580	844
Maximum operating temperature	°C	90	90	90

Maximum operating pressure Primary: 4 bar Secondary: 10 bar

Performance Data

		SL320	SL420	SL600
Litres in first 10 minutes	40°C	922	1195	1345
Litres in first 10 minutes	45°C	790	1012	1153
Litres in first 10 minutes	60°C	504	620	706
Litres in first hour	40°C	2666	3151	3437
Litres in first hour	45°C	2285	2608	2946
Litres in first hour	60°C	1368	1513	1733
Continuous flow 40°C	Ltrs/hr	2093	2536	2511
Continuous flow 45°C	Ltrs/hr	1794	2058	2152
Continuous flow 60°C	Ltrs/hr	1037	1153	1232
Initial heat up time 10°C to 85°C	Min	23	24	35

Please Note: Performance data assumes a primary flow temperature of 85°C and a domestic cold water supply of 10°C without the use of a thermostatic mixing valve on the domestic hot water outlet.

Characteristics

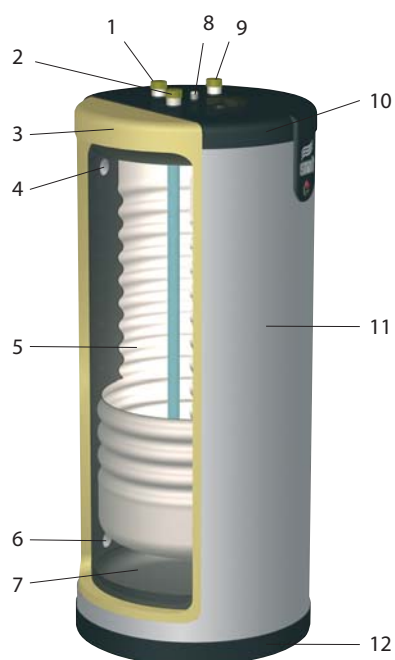

1. DHW return or temp/pressure relief valve
2. Cold feed
3. Insulation 50mm
4. Primary hot water flow
5. DHW tank
6. Primary return
7. Primary hot water
8. Air vent
9. DHW flow
10. Rigid top case
11. Stain resistant jacket
12. Rigid base

Dimensions

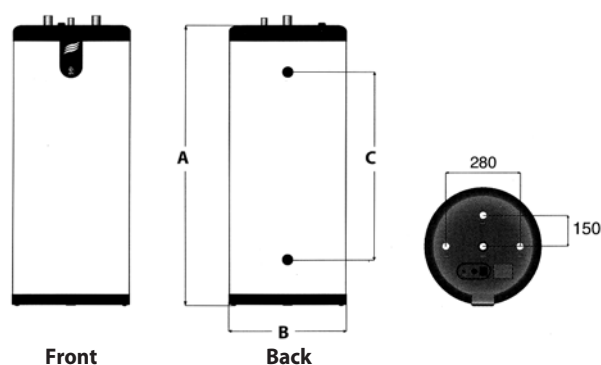

	SL320	SL420	SL600
A	1550mm	1975mm	1835mm
B	660mm	660mm	817mm
C	1030mm	1455mm	1328mm

High efficiency hot water storage



SmartLine SLME

Designed for a range of applications and a multiple choice of energy sources.

Multi-Energy cylinder with the advantages of Tank-in-Tank technology and the added benefit of a carbon steel coil located at the bottom in the primary water. The large heating surface area and increased primary volume of the SLME tanks not only increase recovery time, but also ensure all energy from your renewable source is absorbed into the tank, reducing fuel bills and ultimately helping the environment.

Due to the unique design of the Multi-Energy cylinder and the large primary thermal store, it is the perfect partner for Solar, Heat Pumps, Pellet Burners, Heat Recovery Systems, District Heating Applications and more.

Advantages Over Twin Coil Tank

- Increased heating surface for rapid domestic hot water recovery
- Large primary volume allows for greater thermal store
- Can be used as a low loss header for heating circuit
- Smaller compact tank with increased performance
- Immersion heater in primary circuit
- More heat sources absorbed into the tank
- Flexible design options for specifiers and installer
- Extra primary connections for connecting to heating circuit

When to install a Smart Line Multi Energy

Solar applications

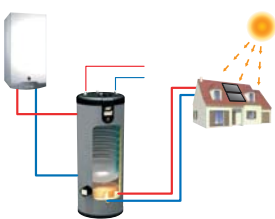

District/centralised heating applications

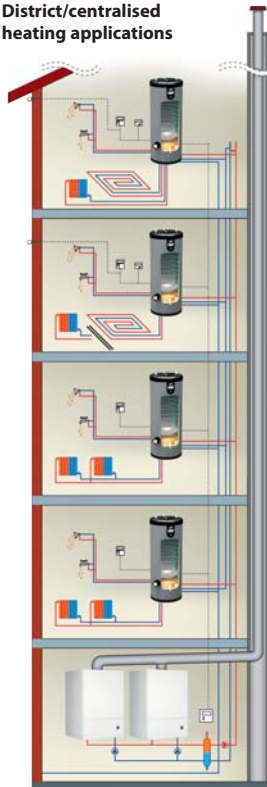

Wood/pellet boiler applications

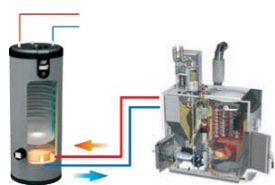

Heat pump applications

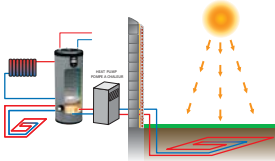

1. Polypropylene top lid
2. Polypropylene shell
3. Stainless steel tank (DHW)
4. Polypropylene bottom lid
5. Manual air purge
6. Polyurethane foam insulation
7. Dry well for sensors
8. Outer steel tank (primary circuits) see diagrams page 9
9. Electric heating element
10. Carbon steel coil

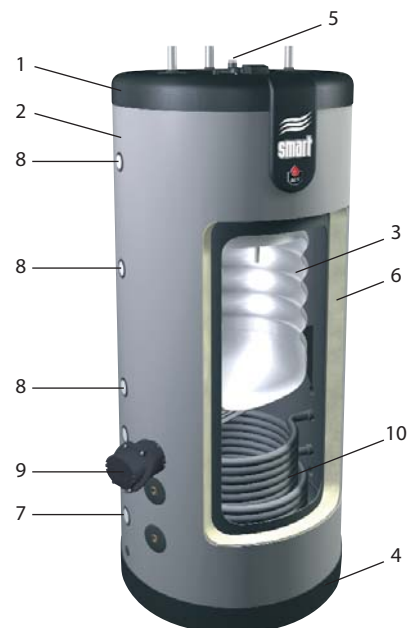

Technical Data

		SLME120	SLME200	SLME300	SLME400	SLME600
Total capacity	L	123	203	303	395	606
Primary capacity	L	46	95.7	165	219	365
Domestic capacity	L	77	99	126	164	225
Coil capacity	L	3	8.3	12	12	16
Primary fluid flow rate	Ltrs/hr	2100	3000	3000	3000	3000
Coil fluid flow rate	Ltrs/hr	2300	3000	3000	3000	3000
Primary pressure drop	mbar	32	40	42	45	48
Coil pressure drop	mbar	160	460	533	533	186
Tank heating surface	m ²	1.08	1.26	1.46	1.94	1.90
Coil heating surface	m ²	0.78	1.42	1.80	1.80	2.50
Max operating pressure heating circuit	bar	3	3	3	3	3
Max operating pressure DHW circuit	bar	10	10	10	10	10
Max operating pressure coil circuit	bar	10	10	10	10	10
Max operating temperature	°C	90	90	90	90	90
Weight empty	kg	65	68	99	120	180
Coil connection	Ø	3/4" F	1" F	1" F	1" F	1" F
Primary connection	Ø	3/4" F	1" F	1" F	1" F	1" F
Secondary connection cold DHW	Ø	3/4" F	3/4" M	3/4" M	3/4" M	3/4" M

Performance Data

		Heating Source - external boiler connected to tank				
		SLME120	SLME200	SLME300	SLME400	SLME600
Litres in first 10 minutes	40°C	300	321	418	558	686
Litres in first 10 minutes	45°C	242	275	348	464	582
Litres in first 10 minutes	60°C	146	161	206	274	358
Litres in first hour	40°C	938	1063	1225	1633	1872
Litres in first hour	45°C	751	911	1003	1338	1559
Litres in first hour	60°C	426	536	590	786	935
Continuous flow at 40°C	L/h	827	890	967	1289	1423
Continuous flow at 45°C	L/h	673	763	786	1048	1172
Continuous flow at 60°C	L/h	378	450	461	614	693

Please Note: Performance data assumes a primary flow temperature of 85°C and a domestic cold water supply of 10°C

Dimensions

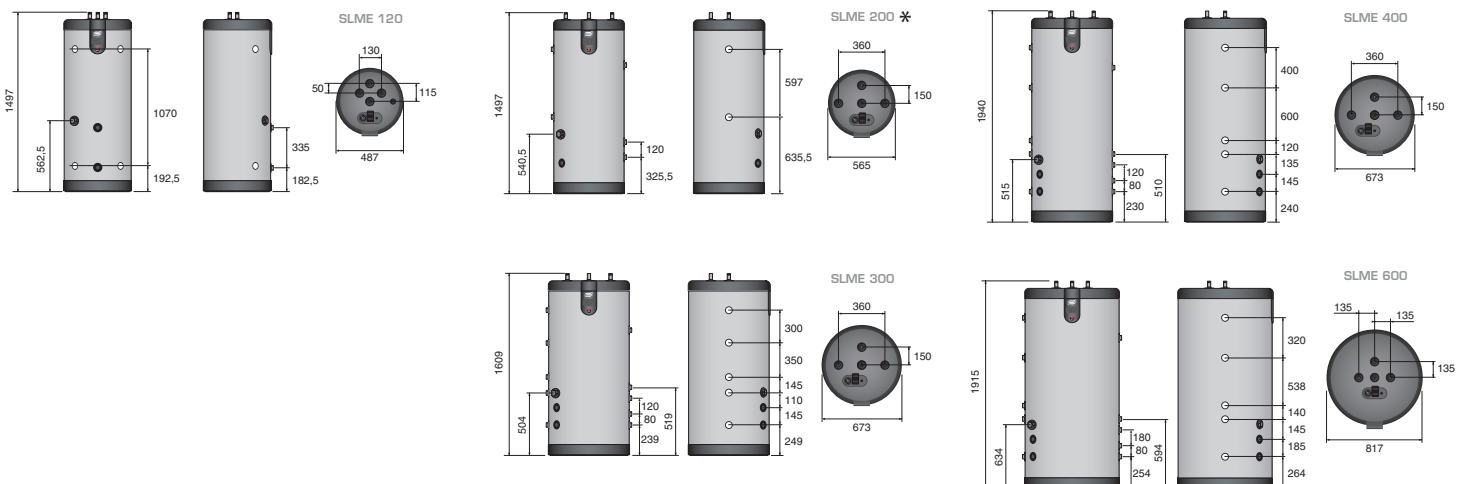

*SLME 200 – Solar tank only (no outer jacket connection for heating circuit). Consult ACV for details - see website.

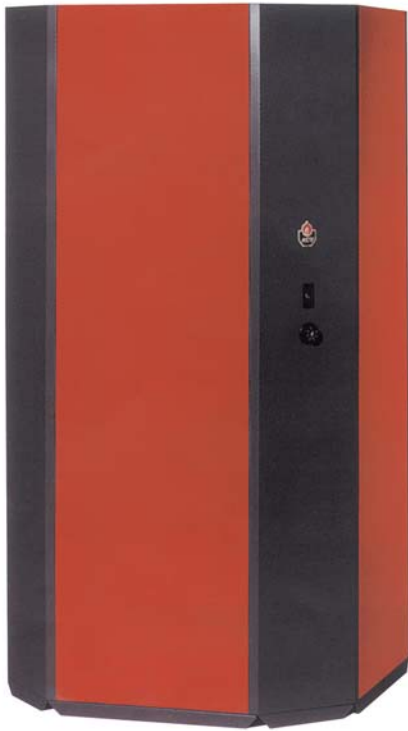

Jumbo

Fast recovery Tank-in-Tank hot water storage.

A large heat exchange surface (1.5 to 2.5 times more than that of a traditional coil) enables the Jumbo to heat a high volume of domestic hot water in a very short time. The unique design of the heat exchanger offers reduced recovery times and improves the overall efficiency and performance of the installation.

- Tank-in-Tank floor standing indirect hot water storage tank
- Stainless steel construction - no need for sacrificial anodes
- High performance - fast heat up and rapid recovery
- Fully insulated
- Stove enamelled steel casing, supplied separately to enable the tank to pass through standard 800mm doorways
- Two sizes - 800 and 1000 litres
- Can be used in battery formation for high output installations
- Vented or unvented use, with mains pressure SystemPak available
- Large heating surface area means reduced boiler cycling

Operating Conditions

Cold water	t°	10°C
Hot water	t°	40°C
Heating water	t°	90°C



Incorporated into HeatMaster Scheme

This solution combines the advantages of large storage capacity with those of instantaneous DHW generation. Eliminating all of the problems associated with space and maintenance requirements, reducing operating costs as well as ensuring outstanding domestic hot water performance levels.

JUMBO 1000 HeatMaster® 201

4010 L
of hot water in 10'

8955 L
of hot water in
the first hour



Technical Data

		Jumbo 800	Jumbo 1000
Total capacity	L	800	1000
Primary capacity	L	125	160
Heating surface area	m ²	4.56	5.5
Primary pressure drop	mbar	96	101
Primary flow rate	Ltrs/hr	8600	9600
Maximum useable input from boiler	kW	100	112
Primary connections (female BSP)	Ø	2"	2"
Hot water connections (male BSP)	Ø	2"	2"
Weight empty	kg	360	380
Weight full	kg	1160	1380
Maximum operating temperature	°C	90	90

Maximum operating pressure Primary: 5 bar Secondary: 10 bar

Performance Data

		Jumbo 800	Jumbo 1000
Litres in first 10 minutes	40°C	1881	2265
Litres in first 10 minutes	45°C	1612	1941
Litres in first 10 minutes	60°C	961	1145
Litres in first hour	40°C	4270	4940
Litres in first hour	45°C	3660	4234
Litres in first hour	60°C	2124	2438
Continuous flow 40°C	Ltrs/hr	2868	3210
Continuous flow 45°C	Ltrs/hr	2458	2751
Continuous flow 60°C	Ltrs/hr	1395	1552

Characteristics

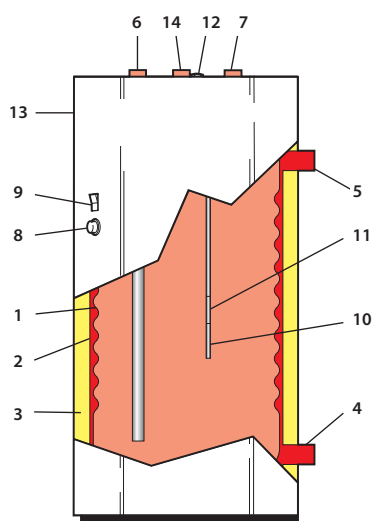

1. Stainless steel inner tank
2. Steel outer tank
3. 120 mm thick mineral wool insulation
4. Primary water return connection
5. Primary water flow connection
6. Domestic cold water inlet
7. Domestic hot water outlet
8. Control thermostat
9. Thermometer
10. Thermostat pocket
11. Thermometer pocket
12. Primary air vent
13. Metal casing
14. DHW recirculation or temperature and pressure relief valve connection

Dimensions

	Jumbo 800	Jumbo 1000
A	1915mm	2315mm
B	1590mm	1990mm
C	1020mm	1020mm
D	1020mm	1020mm

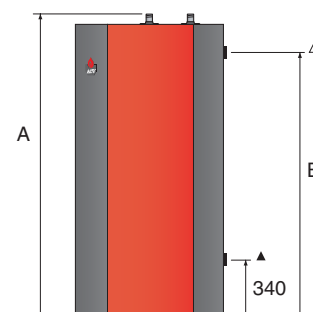
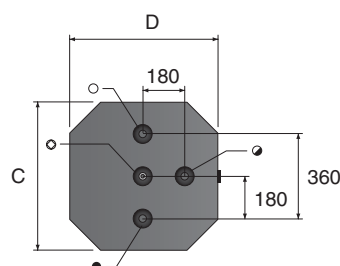



HeatMaster[®] 35TC-85TC

Total condensing storage combination boiler -
Sedbuk A rated.

With the high levels of building insulation now in place in most properties, the requirements for heating output are reducing – this trend is set to continue with some experts predicting a drop in the boiler load due to heating from around 75% to as low as 45%. At the same time, hot water usage is increasing year-by-year as demand rises for luxury bathing facilities such as high performance showers and spa baths. If hot water demand has risen to 55% of the boiler load, the natural progression is to gain as much efficiency in hot water mode as possible.

The HeatMaster TC can also be used as a standalone water heater.

MCBA electronic control fitted as standard. Managing boiler and burner functions, this helps reduce the stop/start cycle significantly, ultimately saving fuel and component wear and tear.

Additional controls available, please discuss your requirements with our technical department.

How does it work?

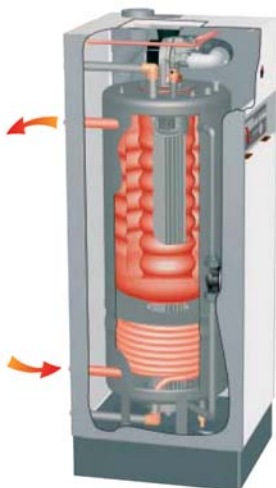

Heating

The heating return enters the lower circuit of the boiler, which allows the boiler to operate in condensing mode. The upper circuit of the HeatMaster TC is kept at a consistently high temperature due to the internal shunt pump which ensures that the primary water circulates around the heat exchanger flue tubes.

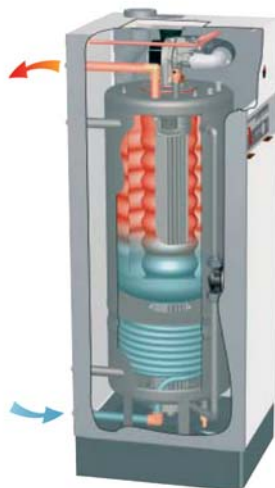

Hot Water

With the upper circuit maintained at a high temperature, the HeatMaster TC is always ready to supply hot water on demand. The cold water enters through the dual coil at the base of the heat exchanger and is pre-heated before entering the hot water tank. The low temperature of the bottom circuit results in continuous condensation of the flue gases in hot water mode.

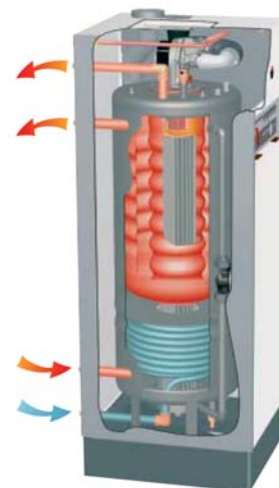

Heating and Hot Water

Once up to temperature, the HeatMaster TC is capable of producing heating and hot water simultaneously.

Technical Data

		HeatMaster® 35TC		HeatMaster® 85TC	
		Natural Gas	LPG	Natural Gas	LPG
Fuel					
Input max/min	kW	34.9/10.0	30.6/10.0	85.0/17.2	85.0/17.2
Output max/min	kW	34.1/9.8	29.9/9.8	82.5/16.5	82.5/16.5
Efficiency hot water mode	%	105.9	105.9	103.9	103.9
Efficiency heating mode (30% load EN677)	%	108.5	108.5	107.8	107.8
SAP seasonal efficiency	%	90.9	92.6	-	-
Total capacity	L	189	189	315	315
Primary capacity	L	108.5	108.5	125	125
Gas connection (male)	Ø	3/4"	3/4"	3/4"	3/4"
Primary flow & return connection (female)	Ø	1"	1"	1 1/2"	1 1/2"
Secondary hot water Connection (male)	Ø	1"	1"	1"	1"
Flue connection	Ø mm	80/125	80/125	100/150	100/150
Max length concentric flue	mtr	20	20	8	8
Nox class (EN483)		class 5	class 5	class 5	class 5
Weight empty	kg	174	174	284	284
Natural gas flow rate - 20mbar	m³/h	3.7		8.99	
Pressure drop	mbar	30	30	200	200
Maximum operating temperature	°C	90	90	90	90
Maximum operating pressure Primary: 3 bar Secondary: 10 bar					

Performance Data

		HeatMaster® 35TC		HeatMaster® 85TC	
Litres in first 10 minutes	40°C		419		850
Litres in first 10 minutes	45°C		381		722
Litres in first 10 minutes	60°C		224		459
Litres in first hour	40°C		1312		3177
Litres in first hour	45°C		1080		2717
Litres in first hour	60°C		692		1778
Continuous flow 40°C	Ltrs/hr		1057		2793
Continuous flow 45°C	Ltrs/hr		898		2394
Continuous flow 60°C	Ltrs/hr		578		1583

Please Note: Performance data assumes a primary flow temperature of 85°C and a domestic cold water supply of 10°C

Dimensions

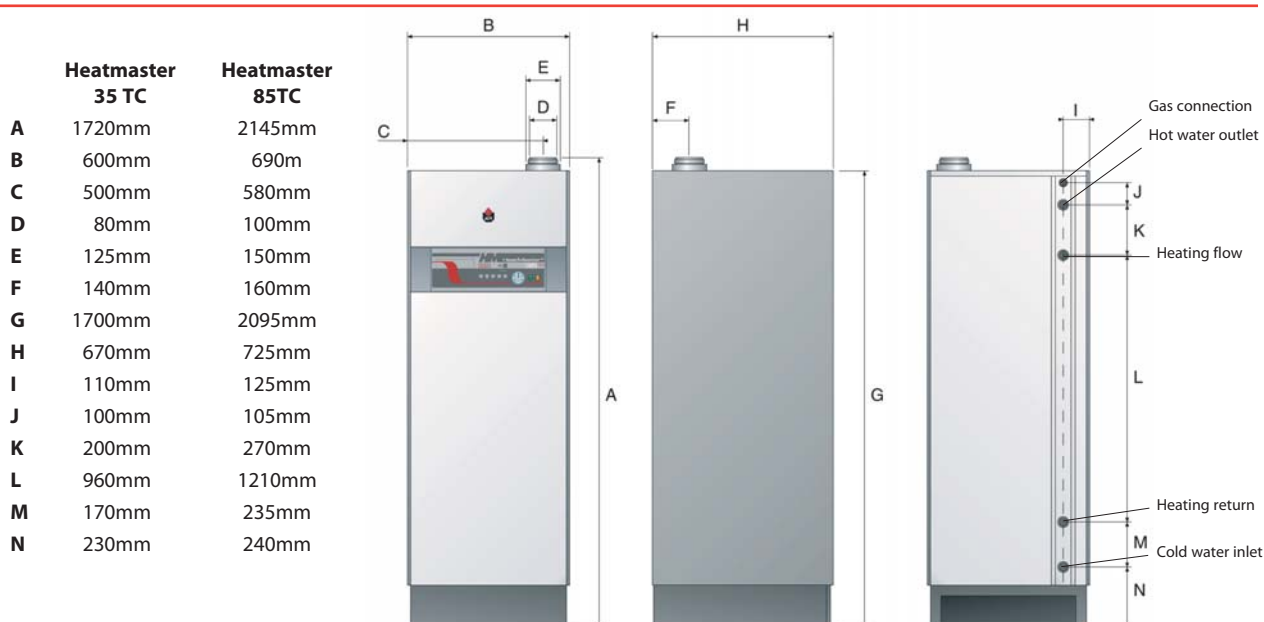

HeatMaster[®] 60

High performance, combined direct fired boiler and water heater. Can also be used as a stand alone water heater.



Simple, Well Proven Performance

At the heart of the HeatMaster is a stainless steel cylinder through which the flue tubes pass. This is surrounded by a mild steel shell containing the primary water.

The outer shell extends down to the combustion chamber and around the flue tubes. The heat transfer surface is therefore much greater than that of standard direct fired water heater. A circulating pump fitted to the primary circuit moves the water around the tank, heating it faster and maintaining an even temperature across the primary jacket.

The burner fires into the combustion chamber which indirectly heats the stainless steel cylinder containing the DHW. As with all Tank-in-Tanks, this is corrugated over its full height and suspended in the HeatMaster by its hot and cold water connections.

It is capable of operating at very high temperatures.

Key Benefits

- Limescale build up is prevented because the:
 - cylinder expands and contracts during use
 - cold water does not come into contact with the intense heat of the burner flame
- No need for sacrificial anodes due to:
 - scale resistant features
 - corrosion resistance of stainless steel
- The HeatMaster has one very major advantage over other direct fired water heaters
 - because it heats the DHW with a primary circuit, this primary water can be used to provide central heating as well
- Most hot water and heating demands can be met - simply by connecting two, three, four or more HeatMasters together in a module.
- The HeatMaster range can be used in conjunction with SL and Jumbo hot water storage tanks – supplying even the largest hot water requirement.

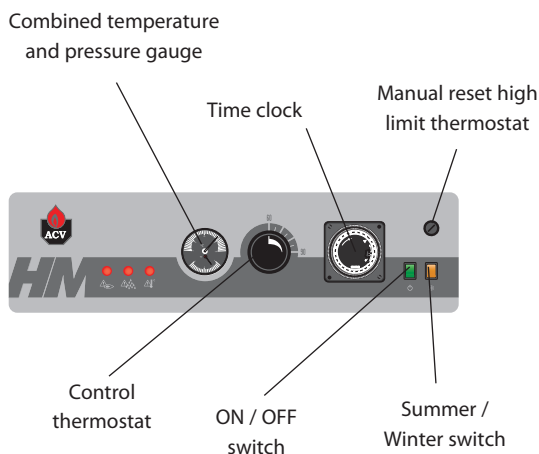
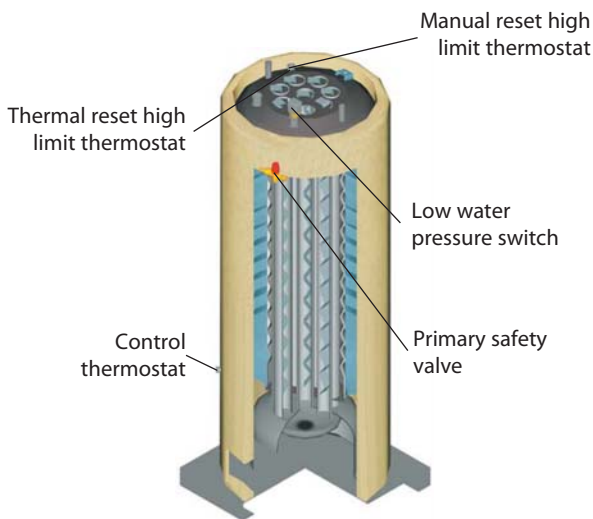

Technical Data

		HeatMaster®60	HeatMaster®60
		Oil (28 sec or 35 sec)	Natural gas/LPG
Fuel		Oil (28 sec or 35 sec)	Natural gas/LPG
Burner options	type	Pressure Jet	BG2000-S or forced draught
Input	kW	69.9	69.9
Maximum output	kW	62.5	63.0
Primary capacity	L	82	82
Total capacity	L	162	162
Heating surface area	m ²	2.46	2.46
Primary circuit pressure drop	mbar	54	54
DHW tank pressure drop	mbar	45	45
Flue circuit pressure drop	mbar	0.6	0.6
DHW connection (male BSP)	Ø	3/4"	3/4"
Primary connection (female BSP)	Ø	1 1/2"	1 1/2"
Flue connection (G)	Ø mm	150	150
Flue connection options	type	B23	B23/C13/C33/C53
BG2000 air intake connection	Ø mm	n/a	80
Weight empty	Kg	220	220
Weight full	Kg	382	382
Minimum working gas pressure	mbar	n/a	20(Nat Gas)/37(LPG)
Gas flow rate	m ³ /h	n/a	7.40(Nat Gas)/2.86(LPG)
Maximum operating temperature	°C	90	90

Maximum operating pressure Primary: 3 bar Secondary: 10 bar
Gas connection - BG2000 S/60: 3/4"

Performance Data

HeatMaster®60		
Litres in first 10 minutes	40°C	474
Litres in first 10 minutes	45°C	378
Litres in first 10 minutes	60°C	245
Litres in first hour	40°C	1942
Litres in first hour	45°C	1656
Litres in first hour	60°C	1106
Continuous flow 40°C	Ltrs/hr	1835
Continuous flow 45°C	Ltrs/hr	1573
Continuous flow 60°C	Ltrs/hr	1101
Reheat time to 60°C	Min	9

Characteristics

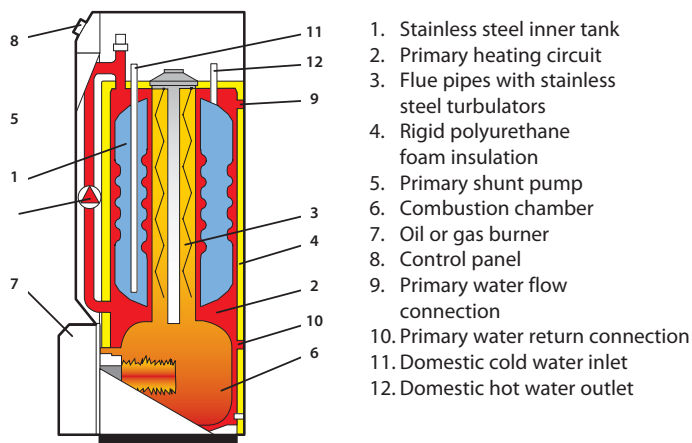

Dimensions

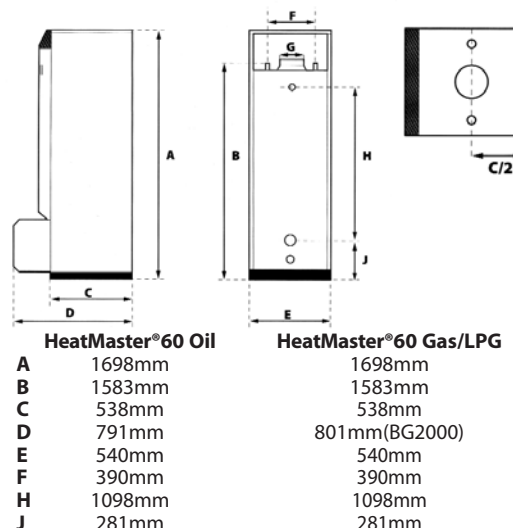



HeatMaster[®] 70-100

High performance heating and hot water generator. Can also be used as a stand alone hot water generator capable of operating at an elevated temperature.

Simple, Well Proven Performance

At the heart of the HeatMaster is a stainless steel cylinder through which the flue tubes pass. This is surrounded by a mild steel shell containing the primary water.

The outer shell extends down to the combustion chamber and around the flue tubes. The heat transfer surface is therefore much greater than that of standard direct fired water heater. A circulating pump fitted to the primary circuit moves the water around the tank, heating it faster and maintaining an even temperature across the primary jacket.

The burner fires into the combustion chamber which indirectly heats the stainless steel cylinder containing the DHW. As with all Tank-in-Tanks, this is corrugated over its full height and suspended in the HeatMaster by its hot and cold water connections.

Self-descaling

The tank has freedom of movement: its walls expand and contract with the changes in pressure thus preventing scale forming on the walls. Finally, the cold water injected strikes against the bottom of the tank and carries all suspended particles into the system, helping to prevent deposits forming in the tank. This unique self-descaling feature ensures that the boiler always operates with maximum efficiency.

Benefits & Features

- High performance combined boiler and water heater
- Stainless steel Tank-in-Tank design
- Choice of burner:
 - Low-NOx premix gas or LPG (BG2000-S),
 - Forced draught natural gas or LPG
 - Pressure jet 28 sec or 35 sec oil
- Can also be used as a stand-alone water heater
- Anti-Legionellae: hot water stored at a consistently high temperature
- Built-in primary circuit shunt pump
- Fully insulated with rigid polyurethane foam
- Stove enamelled casing
- Control panel including thermostats, combined temperature and pressure gauge, indicators and on/off switch
- Vented or unvented use, with mains pressure SystemPaks available

BG2000-S/70 and BG2000-S/100 Burner

ACV has developed these burners specially for the HeatMaster 70 and 100 models. Part of the BG 2000-S air/gas premix burner range, they have a metal fibre (NIT) flame tube and smooth and near-silent ignition and operation. They are ideal for use in applications where burner noise must be kept to a minimum.

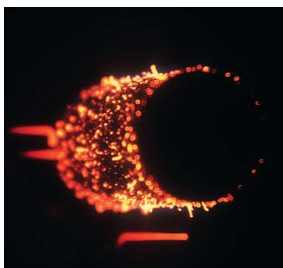

Technical Data

		HeatMaster®70	HeatMaster®70	HeatMaster®100	HeatMaster®100
Fuel		Oil	Gas/LPG	Oil	Gas/LPG
Burner options	type	Pressure Jet	BG2000-S or Forced draught	Pressure Jet	BG2000-S or Forced draught
Input	kW	69.9	69.9	107	107
Maximum output	kW	63	63	96.3	96.3
Primary capacity	L	108	108	130	130
Total capacity	L	239	239	330	330
Heating surface area	m ²	3.14	3.14	3.95	3.95
Primary circuit pressure drop	mbar	46	46	83	83
DHW tank pressure drop	mbar	45	45	180	180
Flue circuit pressure drop	mbar	0.6	0.6	1.4	1.4
DHW connection (male BSP)	Ø	1"	1"	1"	1"
Primary connection (female BSP)	Ø	1 ¹ / ₂ "	1 ¹ / ₂ "	1 ¹ / ₂ "	1 ¹ / ₂ "
Flue connection	Ø mm	150	150	150	150
Flue connection options	type	B23	B23/C13/ C33/C53	B23	B23/C13/C33/C5
BG2000 air intake connection	Ø mm	n/a	80	n/a	100
Weight empty	Kg	270	270	320	320
Weight full	Kg	509	509	650	650
Minimum working gas pressure	mbar	n/a	20(Nat Gas)/37(LPG)	n/a	20(Nat Gas)/37(LPG)
Gas flow rate	m ³ /h	n/a	7.40(Nat Gas)/2.86(LPG)	n/a	8.99(Nat Gas)/3.47(LPG)
Maximum operating temperature	°C	90	90	90	90

Maximum operating pressure Primary: 3 bar Secondary: 10 bar
 Gas connection - BG2000 S/70: 3/4"
 - BG2000 S/100: 1"

Performance Data

		HeatMaster®70 (all burners)	HeatMaster®100 (all burners)
Litres in first 10 minutes	40°C	646	905
Litres in first 10 minutes	45°C	543	777
Litres in first 10 minutes	60°C	346	514
Litres in first hour	40°C	2133	3172
Litres in first hour	45°C	1794	2680
Litres in first hour	60°C	1219	1813
Continuous flow 40°C	Ltrs/hr	1835	2776
Continuous flow 45°C	Ltrs/hr	1573	2379
Continuous flow 60°C	Ltrs/hr	1067	1665
Reheat time to 60°C	Min	16	13

Note: The above performances are based on the hot water being blended at point of use, with a boiler temperature of 90°C and a domestic cold water inlet of 10°C.

Dimensions

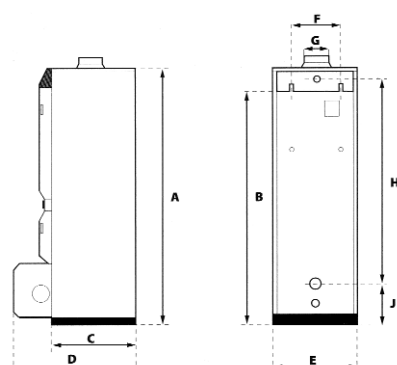

	HeatMaster® 70 Oil	HeatMaster® 70 Gas/LPG	HeatMaster® 100 Oil	HeatMaster® 100 Gas/LPG
A	1743mm	1743mm	2093mm	2093mm
B	1630mm	1630mm	2030mm	2030mm
C	678mm	678mm	678mm	678mm
D	931mm	937(BG 2000)mm	931mm	937(BG 2000)mm
E	680mm	680mm	680mm	680mm
F	390mm	390mm	390mm	390mm
H*	1289mm	1289mm	1693mm	1693mm
J	285mm	285mm	285mm	285mm

*The HeatMaster 100 is currently fitted with two heating flow outlets – the upper connection (recommended) is shown by the dimension H. A second connection (compatible with the previous HM100N) is positioned 365mm lower.

HeatMaster[®] 71-101

High performance combined boiler and water heater with fully modulating burner technology.



The HeatMaster is a high performance hot water producer: its annular Tank-in-Tank holds a volume of hot water for peak demand. This combines the advantages of a hot water producer with integrated storage and of an instantaneous water heater, while avoiding the disadvantages of space, cost and efficiency.

The HeatMaster has a primary circuit and can therefore also be used as a central heating boiler.

Exceptional Performance

The MCBA electronic controller regulates the boiler (start-up, safety, modulation), the shunt pump and the heating pump in response to hot water and heating demand. The MCBA offers numerous advanced features:

- A large burner modulation range - down to less than 30%
- Extremely accurate hot water priority: even very small draw-offs are immediately detected
- The hot water tank is always kept at an optimum temperature
- Excellent hot water performance
- Energy efficiency is optimised in both hot water and heating modes.

Product Features

- High performance **fully modulating** combined boiler and water heater
- Stainless steel Tank-in-Tank design
- Low-NOx premix natural gas/LPG modulating burners
- Can also be used as a stand-alone water heater
- Anti-Legionellae: hot water stored at a consistently high temperature
- Built-in primary circuit shunt pump
- Fully insulated with rigid polyurethane foam
- Stove enamelled casing
- Control panel including digital MCBA controller complete with self diagnostic system and combined temperature and pressure gauge
- Vented or unvented use, with mains pressure SystemPaks available

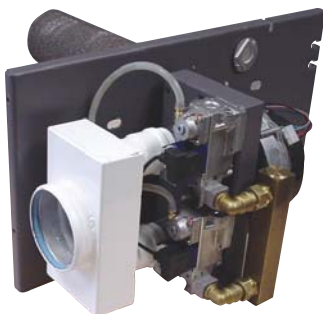

Modulating Burner

The HeatMaster 71 and 101 are fitted with the BG2000-M modulating burner, which has a metal fibre (NIT) flame tube and smooth and near-silent ignition and operation - ideal for use in applications where burner noise must be kept to a minimum.

Technical Data

		HeatMaster® 71	HeatMaster® 101
Fuel		Natural gas/LPG	Natural gas/LPG
Burner options	type	BG2000-M	BG2000-M
Input	kW	20 to 69.9	25 to 107/22 to 110
Maximum output	kW	18.4 to 63	23 to 96.8/20.2 to 99
Primary capacity	L	108	130
Total capacity	L	239	330
Heating surface area	m ²	3.14	3.95
Primary circuit pressure drop	mbar	46	83
DHW tank pressure drop	mbar	45	180
Flue circuit pressure drop	mbar	0.6	1.4
DHW connection (male BSP)	Ø	1"	1"
Primary connection (female BSP)	Ø	1½"	1½"
Flue connection	Ø mm	150	150
Burner air intake connection	Ø mm	80 (BG2000-M)	100 (BG2000-M)
Flue connection options	type	B23/C13/C33/C53	B23/C13/C33/C53
Weight empty	Kg	282	335
Weight full	Kg	521	665
Minimum working gas pressure	mbar	20(Nat Gas)/37(LPG)	20(Nat Gas)/37(LPG)
Gas flow rate	m ³ /h	2.12 to 7.4(Nat Gas/0.82 to 2.86 (LPG)	2.65 to 11.32(Nat Gas/0.9 to 4.5(LPG)
Maximum operating temperature	°C	90	90

Maximum operating pressure Primary: 3 bar Secondary: 10 bar

Gas connection - HM101: 1"
- HM71: ¾"

Performance Data

		HeatMaster® 71	HeatMaster® 101
Litres in first 10 minutes	40°C	646	905
Litres in first 10 minutes	45°C	543	777
Litres in first 10 minutes	60°C	346	514
Litres in first hour	40°C	2133	3172
Litres in first hour	45°C	1794	2680
Litres in first hour	60°C	1219	1813
Continuous flow 40°C	Ltrs/hr	1835	2776
Continuous flow 45°C	Ltrs/hr	1573	2379
Continuous flow 60°C	Ltrs/hr	1067	1665
Reheat time to 60°C	Min	16	13

Note: The above performances are based on the hot water being blended at point of use, with a boiler temperature of 90°C and a domestic cold water inlet of 10°C.

Dimensions

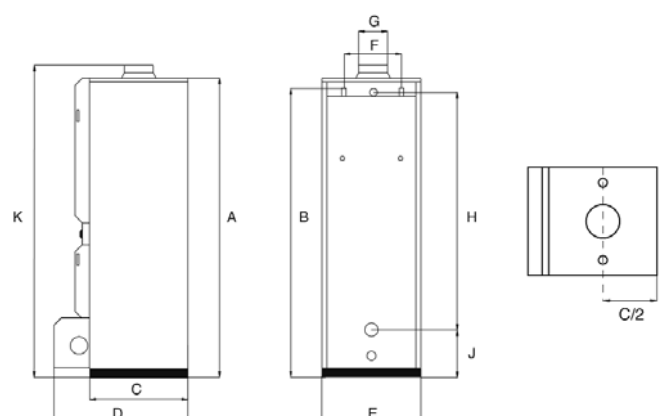

	HeatMaster® 71	HeatMaster® 101
A	1743mm	2093mm
B	1630mm	2030mm
C	680mm	680mm
D	937mm	937mm
E	680mm	680mm
F	390mm	390mm
G Ø	150mm	150mm
H	1289mm	1693mm
J	285mm	285mm
K	1720mm	2120mm



HeatMaster[®] 200

High performance heating and hot water generator. Can also be used as a stand alone hot water generator capable of operating at an elevated temperature.

Tank-in-Tank type exchanger/accumulator

The HeatMaster[®] series differs from traditional hot water generators because of the annular tank immersed in the primary fluid contained in the outer body. The inner tank is itself a stainless steel heat exchanger with a large surface area that enables the water to be heated very quickly.

Self-descaling

The tank has freedom of movement: its walls expand and contract with the changes in pressure thus preventing scale forming on the walls. Finally, the cold water injected strikes against the bottom of the tank and carries all suspended particles into the system, helping to prevent deposits forming in the tank. This unique self-descaling feature ensures that the boiler always operates with maximum efficiency.

HeatMaster[®] 200 N

- High performance water heater
- Performance:
 - 1570 litres in 10'
 - 4920 litres in 60'
 - 4020 litres continuous flow
- Compatible with pressure jet and forced draught burner
- Maximum output 141.7kW
- For greater output on gas see page 22 (HeatMaster 201)

HeatMaster[®] 200 F

- High performance water heater
- Performance:
 - 1675 litres in 10'
 - 5976 litres in 60'
 - 5161 litres continuous flow
- Supplied with Riello RG4S 396 T1 fuel burner
- Maximum output 180.3kW

Features

- Very high performance combined boiler and water heater
- Stainless steel Tank-in-Tank design
- Choice of burner:
 - Forced draught natural gas or LPG
 - Pressure jet 35 sec oil
- Can also be used as a stand-alone water heater
- Anti-Legionellae: hot water stored at a consistently high temperature
- Built-in primary circuit shunt pumps
- Fully insulated with very thick mineral wool
- Stove enamelled casing
- Control panel including thermostats, combined temperature and pressure gauge, indicators and on/off switch
- 178 kW output and up to 3348 litres of hot water at 60°C in one hour
- Vented or unvented use, with mains pressure SystemPaks available
- Anti-stratification pumps as standard

Technical Data

		HeatMaster® 200N	HeatMaster® 200F
Fuel		Gas/LPG	Oil
Burner options		Forced draught	Riello RG4S
Input	kW	154	196
Maximum output	kW	141.7	180.3*
Primary capacity	L	241	241
Total capacity	L	641	641
Heating surface area	m ²	5.3	5.3
Primary circuit pressure drop	mbar	240	240
DHW tank pressure drop	mbar	190	190
Flue circuit pressure drop	mbar	1.5	1.5
DHW connection (male BSP)	Ø	2"	2"
Primary connection (female BSP)	Ø	2"	2"
Flue connection	Ø mm	250	250
Weight empty	Kg	530	530
Weight full	Kg	1171	1171
Maximum operating temperature	°C	90	90
35 seconds Oil flow rate	L/h	-	15.16
Gas flow rate	m ³ /h	23/9	-

*The HeatMaster 200F outputs can only be reached if the boiler is fitted with a RIELLO RG4S 396 T1 fuel burner
 Maximum operating pressure Primary: 3 bar Secondary: 10 bar

Performance Data

		HeatMaster® 200N	HeatMaster® 200F
Litres in first 10 minutes	40°C	1570	1675
Litres in first 10 minutes	45°C	1350	1444
Litres in first 10 minutes	60°C	915	961
Litres in first hour	40°C	4920	5976
Litres in first hour	45°C	4221	5131
Litres in first hour	60°C	2925	3126
Continuous flow 40°C	Ltrs/hr	4020	5161
Continuous flow 45°C	Ltrs/hr	3446	4424
Continuous flow 60°C	Ltrs/hr	2412	2598

Please Note: Performance data assumes a primary flow temperature of 90°C and a domestic cold water supply of 10°C

Characteristics

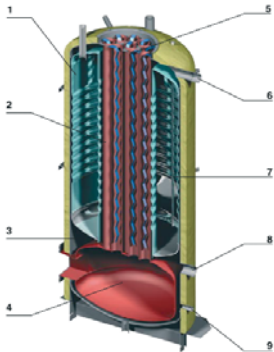

1. "Tank-in-Tank" type storage exchanger
2. Flue ways
3. Primary circuit
4. Combustion chamber
5. Turbulators
6. Heating outlet
7. Stainless steel pocket
8. Heating return
9. Boiler drain cock

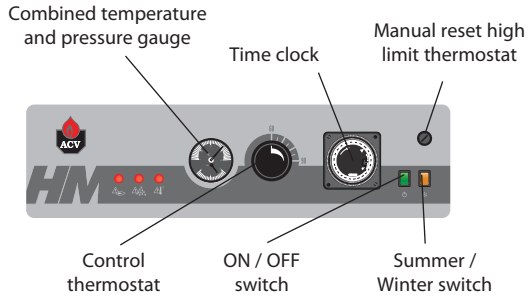

Dimensions

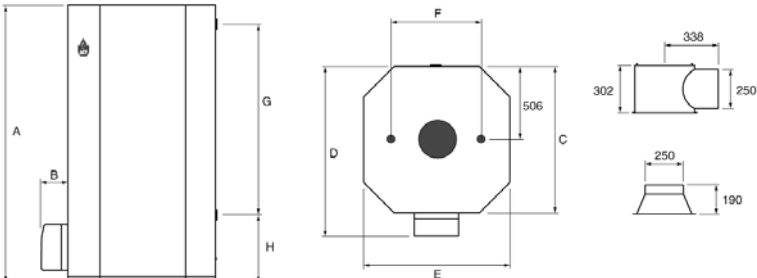

	HeatMaster® 200 Oil	HeatMaster® 200 Gas/LPG
A	2085mm	2085mm
B	-	190mm
C	1020mm	1020mm
D	-	1210mm
E	1020mm	1020mm
F	600mm	600mm
G	1383mm	1383mm
H	590mm	590mm

HeatMaster[®] 201

High performance combined boiler and water heater with fully modulating burner technology.

The HeatMaster is a high performance hot water producer: its annular Tank-in-Tank holds a volume of hot water for peak demand. This combines the advantages of a hot water producer with integrated storage and of an instantaneous water heater, while avoiding the disadvantages of space, cost and efficiency.

The HeatMaster has a primary circuit and can therefore also be used as a central heating boiler.

As with all ACV stainless steel Tank-in-Tank products, it can operate at high temperatures.

Exceptional Performance

The MCBA electronic controller regulates the boiler (start-up, safety, modulation), the shunt pump and the heating pump in response to hot water and heating demand. The MCBA offers numerous advanced features:

- A large burner modulation range - down to less than 30%
- The hot water tank is always kept at an optimum temperature
- Excellent hot water performance
- Energy efficiency is optimised in both hot water and heating modes.

Product Features

- High performance **fully modulating** combined boiler and water heater
- Stainless steel Tank-in-Tank design
- Low-NOx premix natural gas/LPG modulating burner, from 56 to 214 kW
- Can also be used as a stand-alone water heater
- Anti-Legionellae: hot water stored at a consistently high temperature
- Built-in primary circuit shunt pump
- Fully insulated with 50mm rigid polyurethane foam
- Stove enamelled casing
- Control panel including digital MCBA controller complete with self diagnostic system and combined temperature and pressure gauge
- Up to 3534 litres of hot water at 60°C in one hour
- Vented or unvented use, with mains pressure SystemPaks available



Operating Conditions

Cold water	t°	10°C
Hot water	t°	40°C
Heating water	t°	90°C



JUMBO 1000 HeatMaster[®] 201

4010 L
of hot water in 10'

8955 L
of hot water in
the first hour

HeatMaster® 201		
Fuel		Natural gas/LPG
Burner options	type	BG2000-M
Input - heating	kW	60 to 220
Input - hot water	kW	60 to 240
Output - heating	kW	56.4 to 200.2
Output - hot water	kW	56.4 to 218.4
Primary capacity	L	241
Total capacity	L	641
Heating surface area	m ²	5.3
Primary circuit pressure drop	mbar	240
DHW tank pressure drop	mbar	190
Flue circuit pressure drop	mbar	2.9
DHW connection (male BSP)	Ø	2"
Primary connection (female BSP)	Ø	2"
Flue connection	Ø mm	250mm
Weight empty	Kg	550
Weight full	Kg	1191
Minimum working gas pressure	mbar	20/37
Gas flow rate	m ³ /h	25.4/9.81
Maximum operating temperature	°C	90
Maximum operating pressure Primary: 3 bar Secondary: 10 bar		
Gas connection - 1 1/4"		

Performance Data

HeatMaster® 201		
Litres in first 10 minutes	40°C	1745
Litres in first 10 minutes	45°C	1489
Litres in first 10 minutes	60°C	971
Litres in first hour	40°C	6690
Litres in first hour	45°C	5667
Litres in first hour	60°C	3534
Continuous flow 40°C	Ltrs/hr	6117
Continuous flow 45°C	Ltrs/hr	5039
Continuous flow 60°C	Ltrs/hr	2914
Reheat time to 60°C	Min	10.5

Note: The above performances are based on the hot water being blended at point of use, with a boiler temperature of 90°C and a domestic cold water inlet of 10°C.

Dimensions

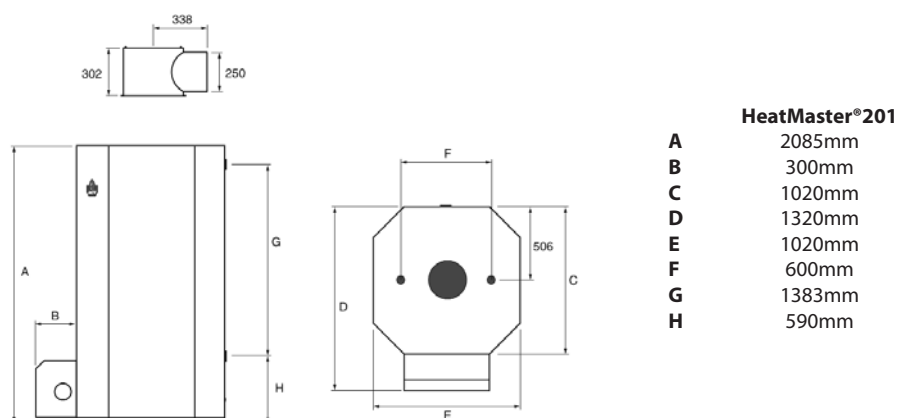

HeatMaster® 201 Condenser

An external condensing unit boosting the efficiency of the incorporated HeatMaster® to 108%.

- Reduced energy bill
- Ideal for large commercial applications
- Minimum space required

The HeatMaster 201 Condenser is delivered with the following.

- HeatMaster insulated body and control panel
- Complete casing
- Flue connection with horizontal exhaust and gasket
- Hydraulic kit, including 4-way valve, pipework and hydraulic fittings and shunt pump
- Gas burner with insulation and gasket

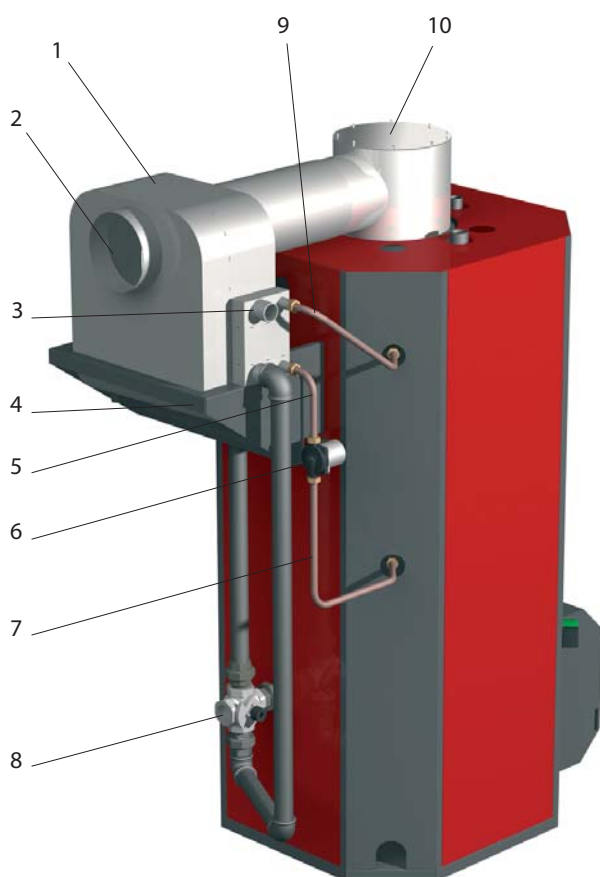

1. Condenser
2. Flue connection
3. Heating return
4. Support bracket
5. Recirculation pipework
6. Recirculation pump
7. Recirculation pipework
8. 4-way valve
9. Recirculation pipework
10. Flue cowling

HeatMaster® 201 Booster

Fuel		Natural Gas/LPG
Burner options	Type	BG2000-M
Input - heating	kW	60 to 220
Input - hot water	kW	60 to 240
Output - heating	kW	58.7 to 210.1
Output - hot water	kW	58.7 to 225.0
Primary capacity	L	245
Total capacity	L	645
Heating surface area	m ²	5.3
Primary circuit pressure drop	mbar	240
DHW tank pressure drop	mbar	190
DHW connection (male BSP)	Ø	2"
Primary connection (female BSP)	Ø	2"
Flue connection	Ø mm	250
Weight empty	kg	580
Weight full	kg	1221
Gas flow rate	m ³ /h	25.4/6.35
Minimum working gas pressure	mbar	20/37
Maximum operating temperature	°C	90

Maximum operating pressure Primary: 3 bar Secondary: 10 bar
Gas connection - 1 1/4"

Performance Data

HeatMaster® 201 Booster

Litres in first 10 minutes	40°C	1745
Litres in first 10 minutes	45°C	1489
Litres in first 10 minutes	60°C	971
Litres in first hour	40°C	7100
Litres in first hour	45°C	5667
Litres in first hour	60°C	3534
Continuous flow 40°C	Ltrs/hr	6425
Continuous flow 45°C	Ltrs/hr	5039
Continuous flow 60°C	Ltrs/hr	2914
Reheat time to 60°C	Min	10.5

Please Note: Performance data assumes a primary flow temperature of 90°C and a domestic cold water supply of 10°C

Dimensions

HeatMaster®
201 Condenser

- A 590mm
- B 2069 mm
- C 2223mm
- D 2387mm
- E 416mm
- F 250mm
- G 416mm
- H 1696mm
- I 1970mm

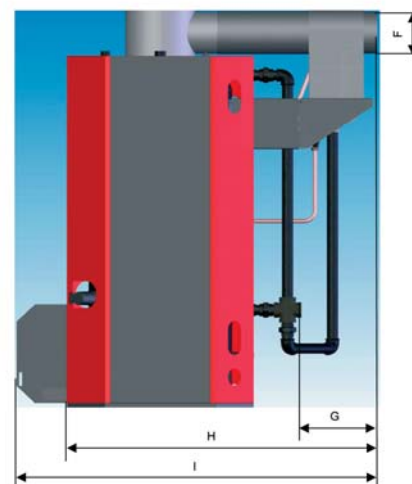
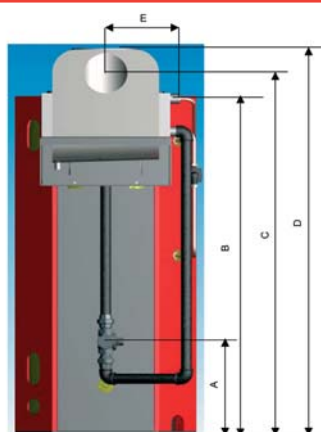

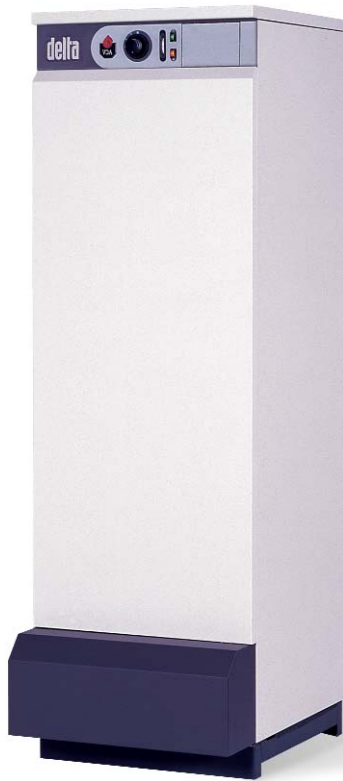

Delta Performance

Floor standing combination boiler. Offers exceptional heating and hot water performance. Available in Gas, Oil and Propane.

Benefits

The Delta Performance is reliable, economical and easy to use and maintain. It is also oil, natural gas or propane compatible. The Delta Performance offers versatility and convenience.

Product Features

- High performance low-cost combined boiler and water heater
- Stainless steel Tank-in-Tank design
- Choice of burner:
 - Low-NOx premix gas or LPG (BG2000-S)
 - Pressure jet natural gas or LPG
 - Pressure jet 28 sec or 35 sec oil
- Anti-Legionellae: hot water stored at consistently high temperature
- Fully insulated with rigid polyurethane foam
- Stove enamelled casing
- Control panel including thermostats, thermometer, indicators and on/off switch
- 22 to 62 kW output (oil) or 22 to 49 kW (gas)
- Can be used in battery formation for high output installations
- Vented or unvented use, with mains pressure SystemPaks available
- Primary heating sealed system kits also available



BG 2000-S Low NOx air/gas premix burners are outstanding not only for their eco-friendly design but also for their incredibly silent operation. They are fitted with automatic ignition and an ionisation flame detector.

Technical Data

		Delta Performance 25	Delta Performance 35	Delta Performance 45	Delta Performance 55
Fuel		Oil (28 sec or 35 sec) or Natural gas			
Burner options	Type	Pressure jet/ BG2000-S			
Input	kW	25/33	33/45	42/61	50/69
Output	kW	22/29	29/40	38/54	45/62
Primary capacity	L	83	104	70	82
Total capacity	L	157	178	132	151
Heating surface area	m ²	1.59	1.59	1.99	2.46
Flue circuit pressure drop	mbar	0.02-0.09	0.08-0.09	0.01-0.08	0.02-0.05
DHW connection (male BSP)	Ø	3/4"	3/4"	3/4"	3/4"
Primary connection (female BSP)	Ø	1"	1"	1"	1"
Flue connection	Ø mm	130	130	150	150
Burner air intake connection	Ø mm	80 - BG2000-S			
Weight empty	kg	145	156	168	200
Weight full	kg	302	334	300	351
Maximum operating temperature	°C	90	90	90	90

Maximum operating pressure Primary: 3 bar Secondary: 10 bar
Gas connection - 3/4" (BG2000 burner)

Performance Data

		Delta Performance 25	Delta Performance 35	Delta Performance 45	Delta Performance 55
Litres in first 10 minutes	40°C	268	285	316	362
Litres in first 10 minutes	45°C	230	230	283	283
Litres in first 10 minutes	60°C	170	170	186	186
Litres in first hour	40°C	806	1035	1284	1533
Litres in first hour	45°C	799	1027	1112	1403
Litres in first hour	60°C	568	727	867	977
Continuous flow 40°C	Ltrs/hr	645	900	1161	1405
Reheat time to 80°C	Min	32	29	16	16

Please Note: Performance data assumes a primary flow temperature of 85°C and a domestic cold water supply of 10°C

Characteristics

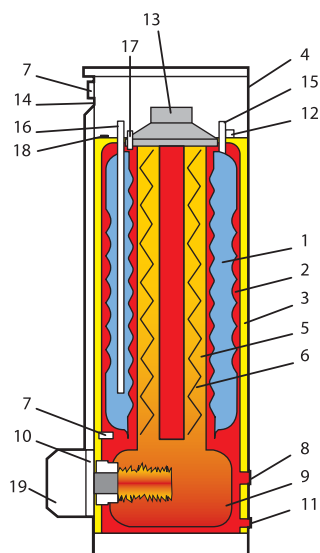

1. Stainless steel inner tank
2. Primary heating circuit
3. Rigid polyurethane foam insulation
4. Stove enamelled metal casing
5. Flue pipes
6. Stainless steel flue turbulators
7. Control thermostat pocket
8. Alternative primary water return connection
9. Combustion chamber
10. Combustion chamber plate
11. Primary drain connection
12. Top primary water flow and return connections
13. Flue connection
14. Control panel
15. Domestic hot water outlet
16. Domestic cold water inlet
17. Lower limit thermostat and thermometer pocket
18. Manual reset high limit thermostat
19. Oil or gas burner

Dimensions

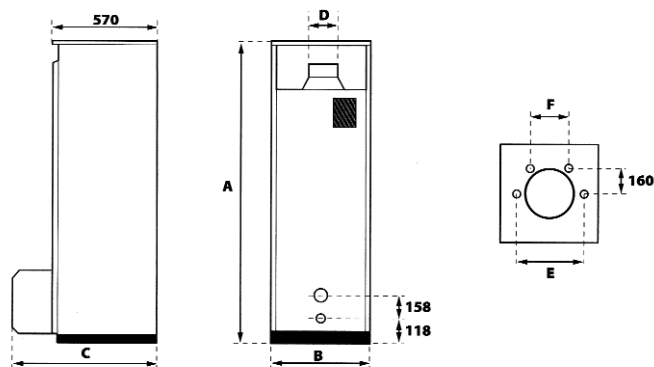

	25	35	45	55
A	1497mm	1697mm	1497mm	1697mm
B	542mm	542mm	542mm	542mm
C	818mm	818mm	818mm	848mm
E	360mm	360mm	390mm	390mm
F	200mm	200mm	200mm	200mm



Delta FV/MV

Floor standing combination boiler – simultaneously meets the heating and hot water requirements of modern life.

Benefits

This high efficiency sealed system boiler incorporates a modulating air/gas premix burner that continually adjusts output to the heating demand and supplies its full power for the hot water requirements (version MV). With high efficiency and energy savings, the FV/MV Delta delivers ease of use for you and easy maintenance for your installer.

- **Balanced flue** combined boiler and water heater
- High efficiency
- Stainless steel Tank-in-Tank design
- Choice of burner:
 - BG2000-M Low-NOx premix modulating gas or LPG
 - BMV pressure jet 28 sec oil (kerosene)
- Choice of 3 flue options
 - vertical or horizontal (all models)
 - twin-tube parallel (gas/LPG only)
- Easy to maintain, with no requirement for flue removal during servicing
- Anti-Legionellae: hot water stored at a consistently high temperature
- Fully insulated with rigid polyurethane foam
- Stove enamelled casing
- Can be used in battery formation for high output installations
- Vented or unvented use, with mains pressure SystemPaks available
- Primary heating sealed system kits also available

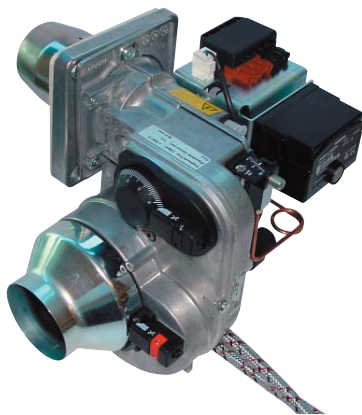

BMV1 and BMV2 Oil Burners

These burners set new standards in oil burner technology. Operating with a transparent flame and a NOx output less than 120 mg/kWh and with low noise levels, they allow easy commissioning and maintenance and offer exceptional efficiency.



BG 2000-MV Low NOx air/gas premix burners are outstanding not only for their eco-friendly design but also for their incredibly silent operation. They are fitted with automatic ignition and an ionisation flame detector.

Technical Data

		Delta FV35	Delta MV35
Fuel		Oil	Natural gas/LPG
Burner options	Type	BMV1	BG2000-M/35
Input	kW	34.9	10 - 34.9
Output	kW	32.62	9.5 - 32
Primary capacity	L	62	62
Total capacity	L	127	127
Heating surface area	m ²	1.99	1.99
Primary circuit pressure drop	mbar	30	30
DHW connection (male BSP)	Ø	¾"	¾"
Primary connection (female BSP)	Ø	1"	1"
Flue connection	Ø mm	80/125	80/125
Weight empty	kg	182	182
Weight full	kg	309	309
Gas flow rate	m ³ /h	n/a	1.06 - 3.7
LPG flow rate	m ³ /h	n/a	0.41 - 1.43
Oil flow rate	kg/h	2.95	n/a
Maximum operating temperature	°C	90	90

Maximum operating pressure Primary: 3 bar Secondary: 10 bar

Performance Data

		Delta FV35	Delta MV35
Litres in first 10 minutes	40°C	283	291
Litres in first 10 minutes	60°C	151	151
Litres in first hour	40°C	1024	1044
Litres in first hour	60°C	598	598
Continuous flow 40°C	Ltrs/hr	920	915
Continuous flow 60°C	Ltrs/hr	513	513
Reheat time to 60°C	Min	20	20

Note: The above performances are based on the hot water being blended at point of use, with a boiler temperature of 80°C and a domestic cold water inlet of 10°C.

Dimensions

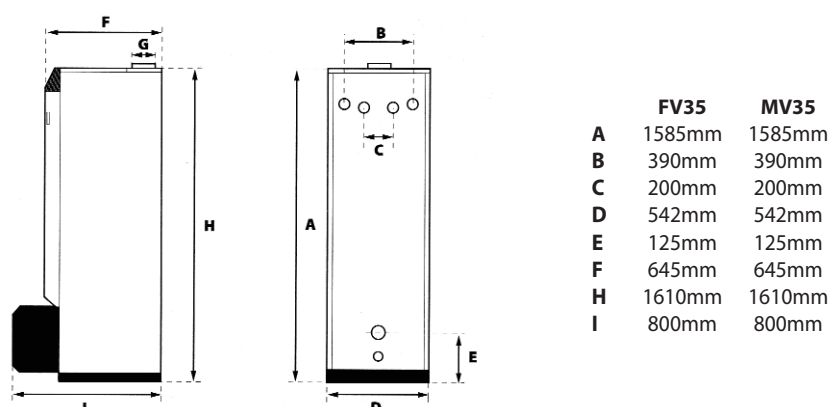

Prestige 24-32

High efficiency domestic wall mounted gas condensing boiler. Stainless steel construction with self-cleaning flue ways.

The prestige can accommodate within its control centre, temperature regulation/full burner modulation via room thermostat, climate control with an outside sensor (optional), and with a combination of outside sensor and room thermostat.

Prestige Excellence - Combination boiler
Incorporated within the jacket, is a 62 litre (total capacity) stainless steel Tank-in-Tank. The Prestige 32 Excellence delivers 224 litres of hot water at 40°C in ten minutes. The Prestige range offers the same anti-scaling, legionella and bacteria risk reduction as all our ACV Domestic Hot Water products.

Prestige Solo - System boiler

The Prestige Solo is designed to operate as either a heating only unit, or, for optimum heating and hot water performance, can be linked to one of the SmartLine range.

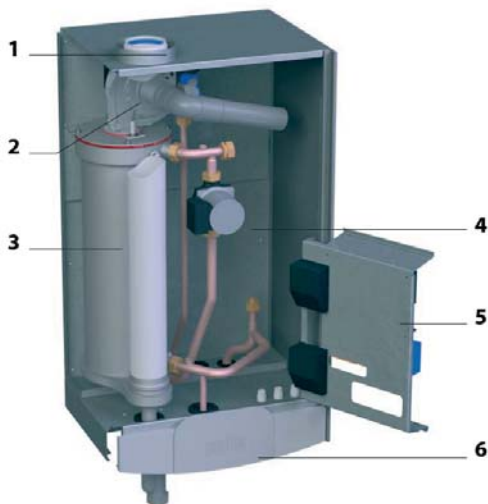

Prestige Solo

1. Chimney connection (concentric tubes \varnothing 80/125mm)
2. Burner, premix and modulating
3. Heat exchanger, stainless steel
4. Pump, central heating
5. Electrical panel (the control boxes on the rear are optional)
6. Control panel

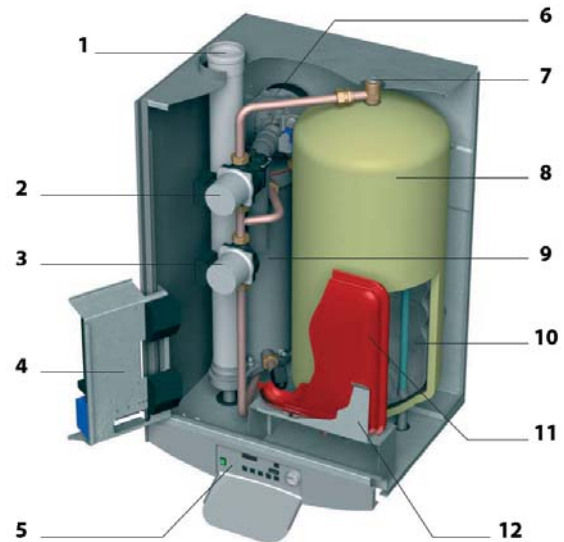

Prestige Excellence

1. Chimney connection (concentric tubes \varnothing 80/125mm)
2. DHW pump with integrated air vent
3. Pump, central heating
4. Electrical panel (the control boxes on the rear are optional)
5. Control panel
6. Burner, premix and modulating
7. Manual air vent
8. Water heater 62 litres
9. Heat exchanger, stainless steel
10. Hot water storage tank, stainless steel
11. Expansion vessel
12. Bracket for expansion vessel

Technical Data

		Solo 24	Solo 32	Excellence 24	Excellence 32
Input	kW	5.9 - 24	7 - 32	5.9 - 24	7 - 32
Max output 60/80°C	kW	23.3	30.8	23.3	30.8
Min output 60/80°C	kW	5.8	5.8	5.8	5.8
Efficiency max output 30/45°C	%	105	104	104.5	104.5
Efficiency min output 30/45°C	%	107	107	109	109
SEDBUK rating		A	A	A	A
CO emissions max/min	mg/kWh	45/20	52/20	45/20	52/20
NOx emissions (EN483)	mg/kWh	66	66	66	66
NOx classification		5	5	5	5
Flue gas temperature - 30/45°C	°C	65	77	65	77
Flue gas temperature - 60/80°C	°C	92	108	92	108
Primary capacity	L	8	8	16	16
Total capacity	L	8	8	70	70
DHW connection (female BSP)	Ø	n/a	n/a	1/2"	1/2"
Primary connection (female BSP)	Ø	1"	1"	1"	1"
Gas connection (male BSP)	Ø	3/4"	3/4"	3/4"	3/4"
Minimum gas pressure	mbar	20	20	20	20
Flue connection	Ø mm	80/125	80/125	80/125	80/125
Max flue length	m	20	20	20	20
Weight empty	kg	50	50	86	86
Weight full	kg	58	58	156	156
Natural gas flow rate - 20mb	m³/h	2.5	3.4	2.5	3.4
Pressure drop	mbar	131	210	131	210
Maximum operating temperature	°C	90	90	90	90

Maximum operating pressure Primary: 3 bar Secondary: 10 bar (Excellence)

Performance Data

		Solo 24	Solo 32	Excellence 24	Excellence 32
Litres in first 10 minutes	40°C	n/a	n/a	175	224
Litres in first 10 minutes	60°C	n/a	n/a	102	103
Litres in first hour	40°C	n/a	n/a	733	835
Litres in first hour	60°C	n/a	n/a	352	353
Continuous flow 40°C	Ltrs/hr	n/a	n/a	653	745
Continuous flow 60°C	Ltrs/hr	n/a	n/a	316	320

Dimensions

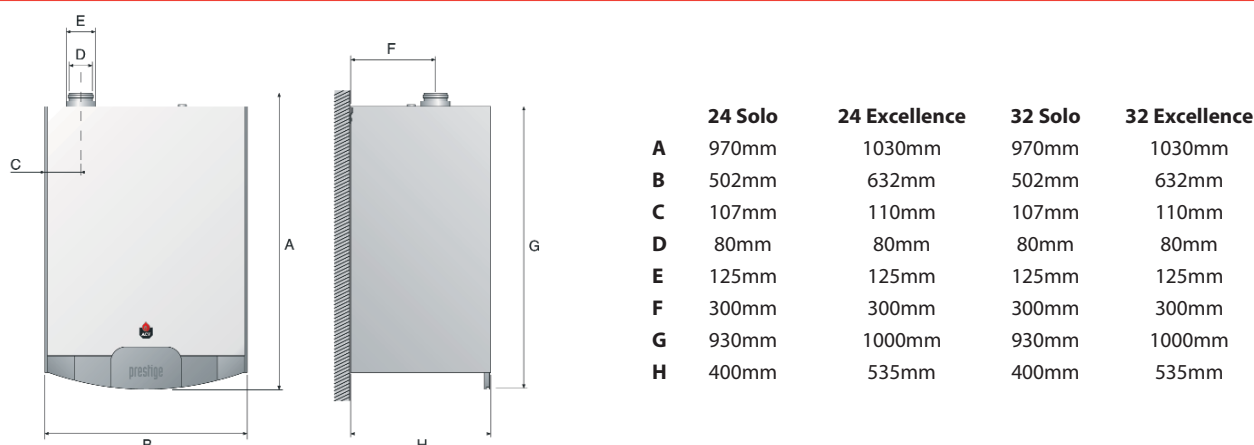

Prestige 50-75-120

High efficiency wall mounted gas-condensing boiler. Stainless steel construction with self-cleaning flue ways.

Prestige boilers combined with ACV SmartLine hot water tanks or HeatMaster combination boilers offer the flexibility of a highly efficient heating and hot water system.

Prestige and ACV Hot Water Tanks

Prestige boilers can be combined with your choice of ACV hot water tank with sizes up to 1000 litres.

Modulating Efficiency

A hot water NTC sensor is connected to the boiler's control system (MCBA). The MCBA will constantly monitor the temperature of the hot water and modulate the boiler output accordingly.

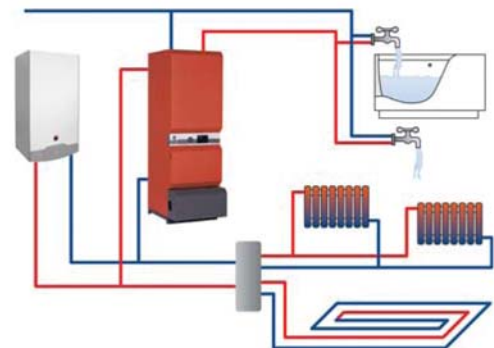
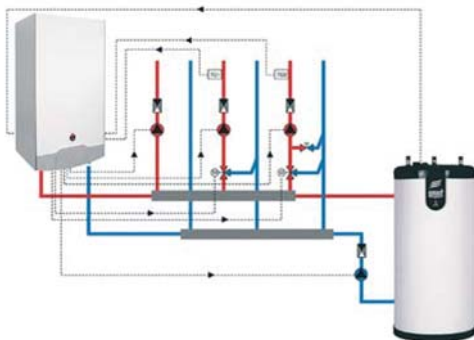

Control

The Prestige benefits from having the ACV advanced MCBA electronic control fitted as standard. This control manages all the gas burner and boiler functions, including its safety parameters and flame modulation, as well as monitoring and controlling the various temperatures across the boiler. Control packages are available upon request.

		Prestige 50	Prestige 75	Prestige 120
Input min/max	kW	15/49.9	18.3/72	22/120
Max output 60/80°C	kW	48.4	69.9	116.6
Min output 60/80°C	kW	14.7	17.9	21.6
Efficiency 30% load (EN887)	%	107.8	107.8	108
SAP seasonal efficiency	%	90.3	90.3	90.3
CO emissions min/max	mg/kWh	20/45	20/52	20/72
NOx emissions min/max	mg/kWh	30/66	38/62	26/70
NOx classification		5	5	5
Flue gas temp 60/80°C	°C	82	82	83
Flue gas temp 30/50°C	°C	40	40	65
Primary capacity	L	20	17	28
Boiler connections (male BSP)	Ø	1 1/4"	1 1/4"	1 1/2"
Gas connection (male BSP)	Ø	3/4"	3/4"	1"
Flue connection	Ø mm	100/150	100/150	100/100 Conventional/twin pipe*
Max flue length	m	20	20	-
Weight empty	kg	54	58	83
Weight full	kg	74	75	111
Natural gas flow rate - 20mb	m ³ /h	5.28	7.6	12.7
Pressure drop	mbar	30	74	80
Maximum operating temperature	°C	90	90	90

*Prestige 120 can only be flued conventional or twin pipe
Maximum operating pressure Primary: 4 bar

Characteristics

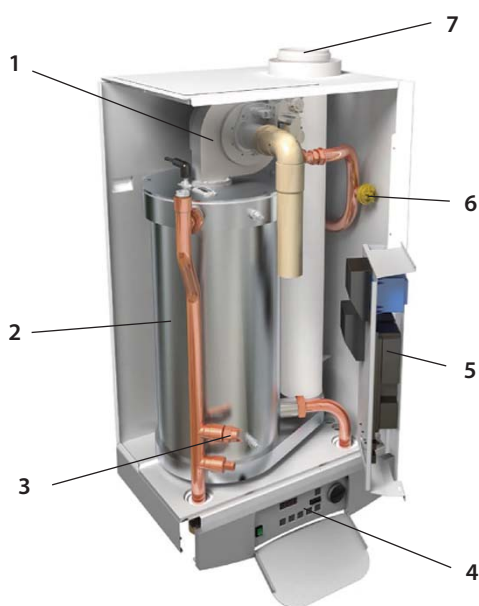

1. Modulating Flue connection gas premix burner
2. ACV stainless steel heat exchanger
3. Low water pressure switch
4. Control panel
5. ACV/MBCA electronic control
6. Gas pressure switch
7. Flue connection

Dimensions

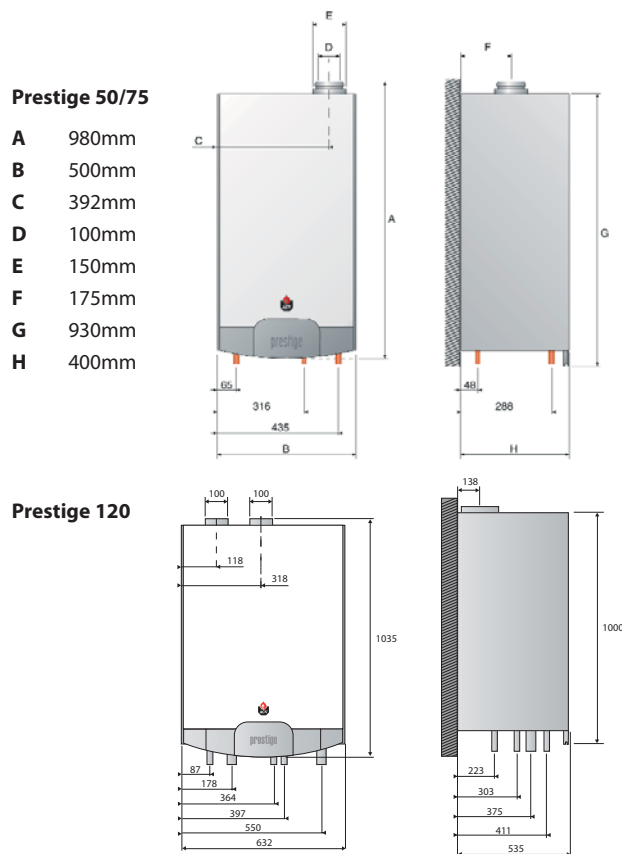

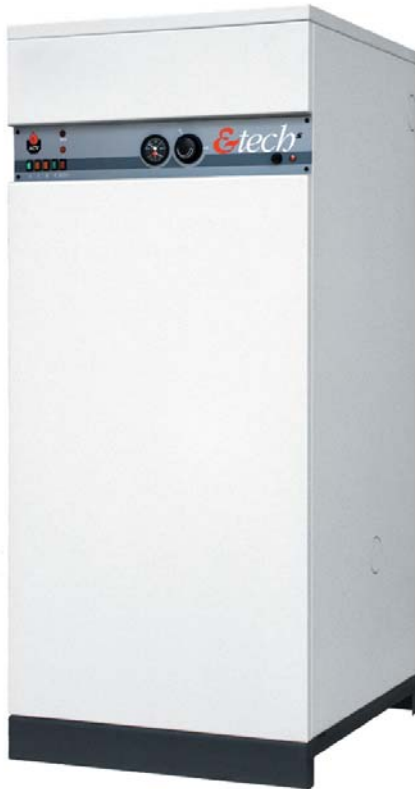

E-Tech S

Compact floor standing combination electric boiler. Flexible installation options.

Sensible Efficiency

For electric to succeed, it is vital that every watt of input finishes up as useful hot water and heating. The new range of E-Tech S Tank-in-Tank thermal storage units is designed to do just that. Four conveniently-sized models are available and each benefits from the clever integration of our stainless steel Tank-in-Tank technology with an equally advanced electric boiler control system. Cupro incoloy elements within the primary water provide the electrical energy.

How It Works

An inner stainless steel hot water storage tank draws heat from primary water circulating through an outer tank which is heated by heavy duty elements. As they're immersed in primary water only, the heating elements are unlikely to be affected by scaling and input to them is modulated by a dual stage thermostat to reduce cycling and load switching. The special design of the inner DHW tank not only helps ensure scale-free operation, but also avoids the sediment problems that plague conventional cylinders. To fully utilise generated energy the Tank-in-Tank unit is wrapped in a generous 70mm of polyurethane insulation.

Benefits and Features

- Quiet operation
- No flue
- Reduced maintenance (no landlord certification)
- Can be used as a stand alone water heater
- Modulating element input
- High hot water storage temperature reduces legionellae bacteria risk
- Flexible installation options for flow and return connections
- Vented or unvented use with pressure SystemPaks available
- Integral primary heating sealed system kit and circulating pump
- Small footprint enabling compact installation
- Integrated controls

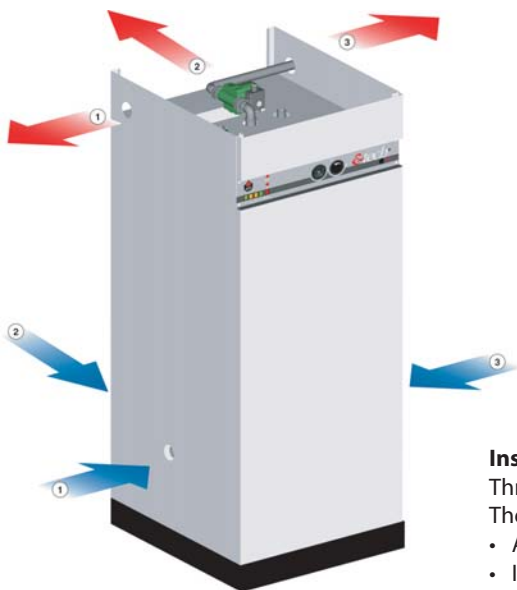

Installation Flexibility

Three choices for heating connections.

The boiler can be installed:

- Against the wall
- In a corner facing left
- In a corner facing right

Technical Data

		E-Tech S 160 Single Phase	E-Tech S 240 Single Phase	E-Tech S 380 Single Phase	E-Tech S 380 Tri-Phase
Maximum output	kW	14.4*	14.4*	14.4*	28.8*
Nominal supply	V	230	230	230	3 x 400 + N
Nominal supply	amps	63	63	63	3 x 42
Primary capacity	L	55	68	127	127
Total capacity	L	161	242	394	394
Heating surface area	m ²	1.26	1.87	2.6	2.6
DHW connection (male BSP)	Ø	3/4"	3/4"	1 1/2"	1 1/2"
Primary connection (female BSP)	Ø	1"	1"	1"	1"
Expansion volume	Ltrs	8	8	2 x 8	2 x 8
Weight empty	kg	115	155	230	230
Weight full	kg	276	397	534	524
Maximum operating temperature	°C	85	85	85	85

*Etech S can be down-rated in steps of 2.4kW (Single Phase) and 7.2kW (Tri Phase).

Maximum operating pressure Primary: 3 bar Secondary: 10 bar

Performance Data

		E-Tech S 160 Single Phase	E-Tech S 240 Single Phase	E-Tech S 380 Single Phase	E-Tech S 380 Tri-Phase
Litres in first 10 minutes	40°C	310	532	855	870
Litres in first 10 minutes	45°C	250	452	725	739
Litres in first 10 minutes	60°C	168	294	468	472
Litres in first hour	40°C	690	880	1200	1516
Litres in first hour	45°C	570	750	1021	1270
Litres in first hour	60°C	375	465	636	752
Continuous flow 40°C	Ltrs/hr	413	413	413	826
Continuous flow 45°C	Ltrs/hr	354	354	354	708
Continuous flow 60°C	Ltrs/hr	248	248	248	448

Please Note: Performance data assumes a primary flow temperature of 85°C and a domestic cold water supply of 10°C

Characteristics

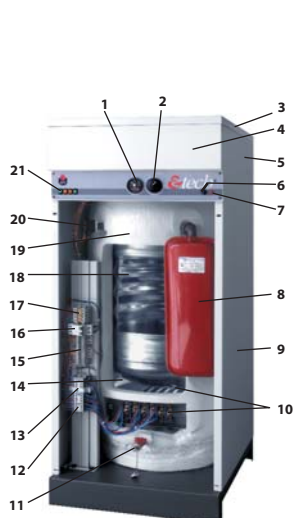

1. Combined temperature/pressure gauge
2. Dual stage control thermostat
3. Removable top panel
4. Upper front panel, removable for access to pipe connections
5. Knockouts for pipe work entry and exit
6. Manual reset high limit thermostat
7. High temperature and low water pressure warning indicator
8. 8 litre expansion vessel/s (one on 160/240, two on 380)
9. Primary water return connection
10. Heating elements
11. Primary drain valve
12. Elements supply contactor
13. Power stage delay timer
14. Primary heating circuit
15. Control circuit connections
16. Control circuit MCB (3 amp)
17. Power cable connections
18. Stainless steel inner hot water tank
19. 70mm polyurethane foam insulation
20. Low water pressure switch
21. Control switches including: on/off, power stage 1, power stage 2 and Summer/Winter switch.

Dimensions

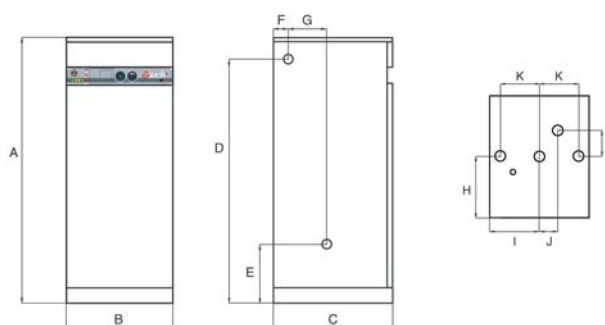

	160	240	380
A	1432mm	1953mm	2134mm
B	620mm	620mm	720mm
C	720mm	720mm	800mm
D	1282mm	1800mm	1985mm
E	290mm	290mm	300mm
F	43mm	43mm	92mm
G	265mm	265mm	265mm
H	405mm	405mm	435mm
I	310mm	310mm	360mm
J	127mm	127mm	94mm
K	180mm	180mm	135mm
L	126mm	126mm	96mm



E-Tech W

Wall mounted electric sealed system boiler. An economical alternative to LPG and Oil.

Available up to 15 kW for single phase supply and, where available, three phase options up to 36 kW.

The E-Tech W is user and installer-friendly with simplified maintenance. The control panel can be rotated to facilitate access to the water connections. The unit is of a steel body with removable stainless steel incoloy elements to increase the reliability and the service life of your installation.

Benefits and Features

- No flue
- Reduced maintenance (no landlord certification)
- Modulating element input
- Can be used in modular formation
- Compatible with Honeywell S-plan and Y-plan wiring systems
- Built-in control circuit protected by internal 3 amp MCB
- Removable stainless steel incoloy immersion elements
- Stove enamelled casing
- Control panel including thermostats, combined temperature and pressure gauge and on/off switch
- Wall mounting bracket included
- Simple connection to heating systems
- Compatible with wet radiator or underfloor heating installations
- Ease of installation - the boiler allows direct connection to a heating system without the need for a feed and expansion tank

Easy connection to underfloor heating

In contrast with electric underfloor heating, hydraulic circuits are compatible with multiple-energy systems (electricity, gas, fuel-oil, heat pump, solar, etc). This allows the user to adapt to changes in the market and to opt for alternative sources of energy as the need arises.

See the ACV multi-energy tanks on page 8.

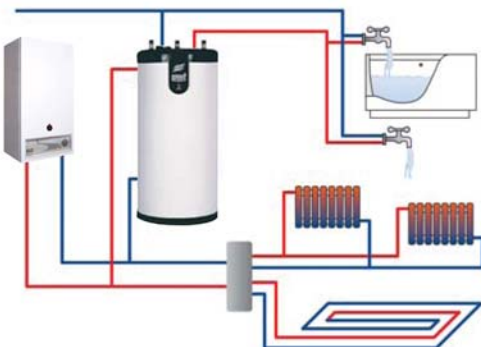

		E-Tech W 09	E-Tech W 15	E-Tech W 22	E-Tech W 28	28 E-Tech W 36
		Single Phase	Single Phase	Tri-Phase	Tri-Phase	Tri-Phase
Output	kW	4.2 to 8.4	7.2 to 14.4	14.4 to 21.6	21.6 to 28.8	30 to 36
Supply	V	230	230	3 x 400 + N	3 x 400 + N	3 x 400 + N
Total capacity	Ltrs	13	13	13	13	13
Expansion volume	Ltrs	10	10	10	10	10
Heating connections	Ø	3/4"	3/4"	3/4"	3/4"	3/4"
Weight empty	kg	45	45	45	45	45
Primary pressure drop	mbar	10	20	45	85	125
Max. operating temp.	°C	85	85	85	85	85
Heating element	type	2 x 1.4kW	2 x 2.4kW	2 x 2.4kW	2 x 2.4kW	2 x 3kW
Number of elements		3	3	5	6	6

Maximum operating pressure Primary: 3 bar

Characteristics

Output modulation

The output of the E-Tech W automatically adjusts to heating demand thanks to the use of a two-stage thermostat:

- The upper thermostat can be adjusted and controls the first stage of output.
- The lower thermostat is automatically regulated 7°C below the setpoint of the upper thermostat. It controls the second stage of output.

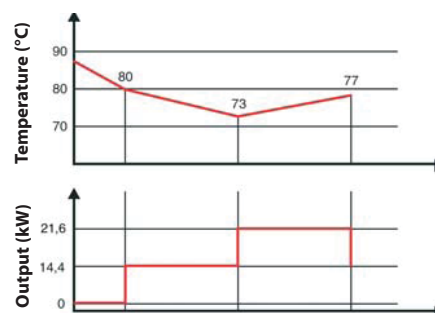

Output modulation (example):
E-Tech W 15
 7.2 or 14.4 kW
E-Tech W 22
 14.4 or 21.6 kW

Characteristics

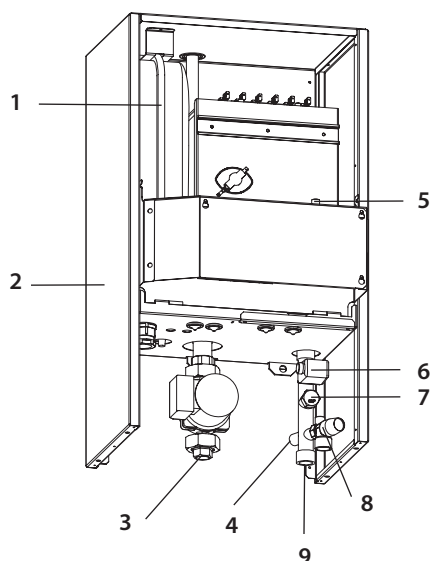

1. Expansion vessel
2. Casing
3. Primary flow
4. Expansion tank connection
5. Manual reset limit thermostat
6. Pressure switch (low water level)
7. DHW kit connection (optional)
8. Safety valve
9. Primary return

Dimensions

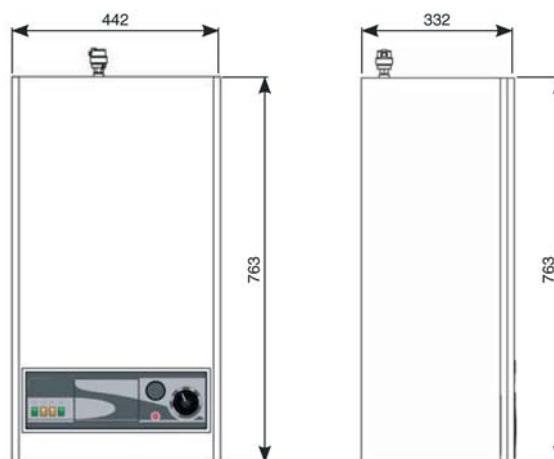



E-Tech P

Floor standing, high output, three phase electric boiler. Use as a primary heat source or emergency back up.

Product Features

- Steel heating body and removable stainless steel heating elements
- Five standard models of 57.6 to 259.2 kW
- Four power stages – controlled by a stage delay timer
- Can easily be de-rated to provide less output if required
- Fully wired power and control circuits
- Stove enamelled casing
- Control panel including thermostats, thermometer, indicators and on/off switch
- Very little maintenance required
- Can also be used in multiple boiler installations

Technical Data

		57	115	144	201	259
Maximum output	kW	57.6	115.2	144	201.6	259.2
Nominal supply – Power circuit	V	3 x 400	3 x 400	3 x 400	3 x 400	3 x 400
Nominal supply – Control circuit	V Hz	1 x 230 50/60	1 x 230 50/60	1 x 230 50/60	1 x 230 50/60	1 x 230 50/60
Heating element type	kW	4 x 3 x 2.4	4 x 3 x 2.4	4 x 3 x 2.4	4 x 3 x 2.4	4 x 3 x 2.4
Number of elements	#	2	4	5	7	9
Ohmic value of single resistance (2.4 kW)	Ohm	22.0	22.0	22.0	22.0	22.0
Total capacity	L	60	60	60	102	102
Max. working pressure	Bar	4	4	4	4	4
Min. working pressure	Bar	0.8	0.8	0.8	0.8	0.8
Maximum operating temperature	°C	90	90	90	90	90
Hydraulic pressure drop	mbar [$\Delta T=10^{\circ}\text{C}$]	20	79	123	20	33
Primary connection (female BSP)	\varnothing	2" [F]	2" [F]	2" [F]	DN100 [*]	DN100 [*]
Weight empty	Kg	110	123	131	187	200

[*] DN100 flanges to be welded

Characteristics

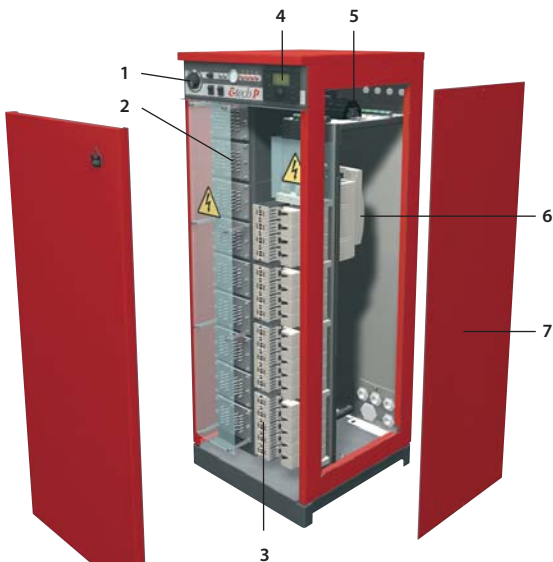

1. Control panel
2. Heating elements
3. Contactor and safety relays
4. Optional controller
5. Control circuit
6. Main fuses and power connections
7. Removable access panel

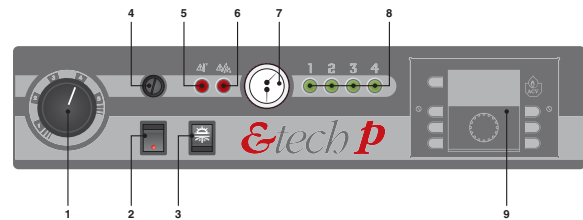

Control Panel

1. Control thermostat
1 = 25°C
2 = 40°C
3 = 55°C
4 = 70°C
5 = 85°C
2. ON/OFF switch
3. Summer/Winter switch
4. Manual reset high limit thermostat
5. Overheating warning light
6. Minimum water pressure warning light
7. Combined temperature and pressure gauge
8. Power levels indicators
9. Optional internal controller

Dimensions

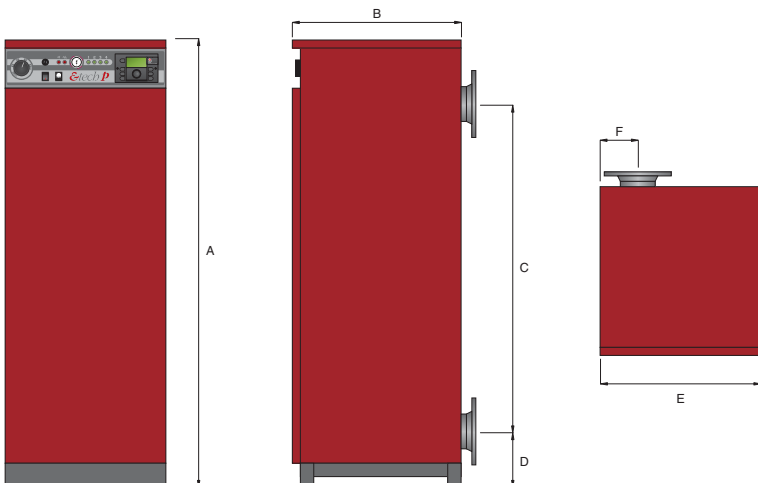

	57	115	144	201	259
A	1495mm	1495mm	1495mm	1495mm	1495mm
B	567mm	567mm	567mm	567mm	567mm
C	550mm	550mm	550mm	1100mm	1100mm
D	183mm	183mm	183mm	183mm	183mm
E	542mm	542mm	542mm	542mm	542mm
F	125mm	125mm	125mm	125mm	125mm



Compact A

High efficiency steel boiler with pressurised combustion chamber – match with natural gas, LPG or oil burner.

Product Features

- Floor standing reverse flame heating boiler
- Robust and reliable steel construction
- Choice of pressure jet oil or forced draught gas burners available
- 3 models of 74 to 235 kW output (larger sizes on request)
- 125mm glass wool insulation
- Combustion chamber door equipped with facility for left or right hand opening
- Control panel including thermostats, thermometer, indicators, power socket and on/off switch
- Delivered to site as a bare shell
 - Allows easy off-loading and positioning
 - Insulation and casing are packed separately, for assembly after installation to avoid damage

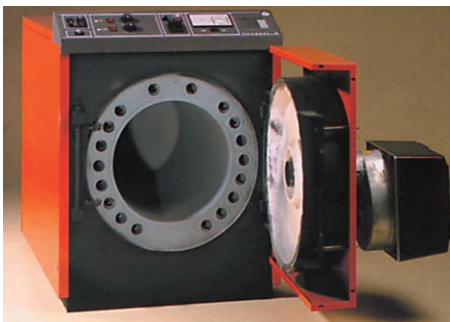

Easy Maintenance

Easy access to the combustion chamber means that cleaning of the boiler and flueways is straightforward.

		Compact A 100	Compact A 150	Compact A 200*
Fuel		Oil (35 sec) or Natural gas/LPG		
Burner options		Pressure Jet oil - forced draught nat gas/LPG		
Maximum input	kW	109	161	260
Minimum input	kW	82	134	137
Maximum output	kW	100	140	235
Minimum output	kW	74	115	185
Mass rate of combustion products - gas	kg/h	189	254	451
Mass rate of combustion products - oil	kg/h	199	288	466
Total capacity	L	102	122	150
Primary connections (flange)	Ø	DN50	DN50	DN65
Safety valve connection (female BSP)	Ø	1"	1"	1"
Open vent connection (female BSP)	Ø	1"	1"	1"
Primary pressure drop	mbar	2 - 5	5 - 11	11 - 31
Flue circuit pressure drop	mbar	0.22 - 0.48	0.68 - 0.96	1.83 - 2.5
Flue connection	mm	200	200	200
Weight empty (excluding burner)	kg	315	380	470
Weight Full (excluding burner)	kg	417	502	620
Natural gas flow rates	m ³ /h	11.4	15.9	26.7
Oil flow rate	Ltrs/hr	9.08	13.35	15.58
Maximum operating temperature	°C	90	90	90

*Larger sizes available upon request.

Maximum operating pressure Primary: 5 bar

Dimensions (excluding burner)

		Compact A 100	Compact A 150	Compact A 200
Length	mm	1295	1495	1795
Height	mm	1000	1000	1000
Width	mm	796	796	796

Characteristics

Control Panel

The control panel includes:

- On/Off switch
- Thermometer
- High/Low thermostats
- High/Low indicator lamps
- High limit thermostat
- Door open warning lamp

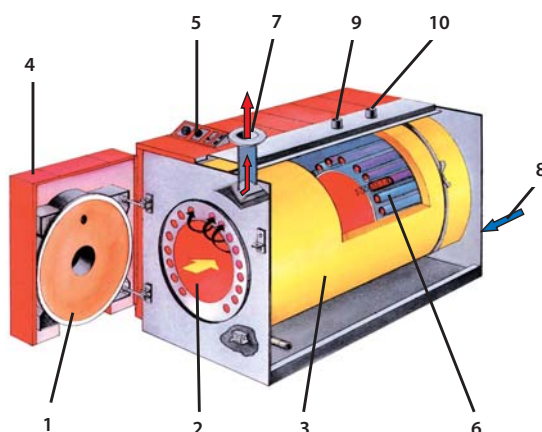

1. Ceramic fibre insulation moulded in one piece overlaid on mineral wool mattress
2. Combustion chamber
3. Glass wool insulation
4. Combustion chamber door
5. Control panel
6. Flue tubes with bimetallic spiral turbulators
7. Primary water flow connection
8. Primary water return connection
9. Safety valve connection
10. Open vent connection



Compact N

Fully assembled compact steel boiler.

High Efficiency steel boiler with pressurised combustion chamber and suitable for matching with Natural Gas, LPG or oil burners. The boiler is a simple, compact unit for small commercial premises and suitable for modular installations where larger outputs are required.

Product Features

- Floor standing boiler with robust and reliable steel construction
- Ideal low-cost choice for both replacement and new installations
- Choice of pressure jet oil or forced draught gas burner
- 3 models with range rateable outputs of 20 to 51kW
- Factory fitted stove enamelled steel casing and glass wool insulation
- Simple to install – and very easy to maintain with left/right handed door opening
- Control panel including thermostats, combined temperature and pressure gauge, and on/off switch
- Can be used in battery formation for higher output installations
- Multi pin plug and socket for electrical connection



Simple Installation

The Compact N is supplied fully assembled, with its robust casing and insulation fitted in the factory. This makes for a simple installation by the installer, with heating flow and return and chimney connections all easily accessible at the rear of the boiler.

Technical Data

		Compact N1	Compact N2	Compact N3
Burner options type		Pressure jet - Forced draught		
Maximum input	kW	28	40	57
Minimum input	kW	22	30	40
Maximum output	kW	25	36	51
Minimum output	kW	20	27	36.5
Total capacity	L	31	37	53
Primary connections (female BSP)	Ø	1"	1"	1 1/4"
Flue circuit pressure drop	mbar	0.15	0.17	0.15
Flue connection	mm	130	130	150
Weight empty (excluding burner)	kg	108	122	157
Weight Full (excluding burner)	kg	139	159	210
Natural gas flow rates	m ³ /h	3.7	4.8	6.6
Oil flow rate	Ltrs/hr	3.43	4.45	5
Maximum operating temperature	°C	90	90	90

Maximum operating pressure Primary: 3 bar

Characteristics

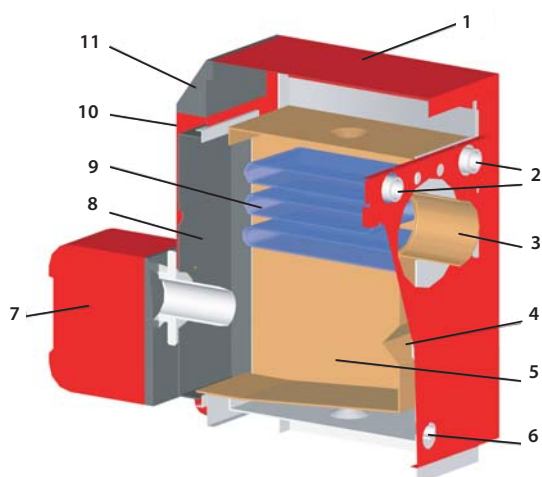

- | | |
|--|---------------------------------------|
| 1. Top cover | 7. Oil or gas burner |
| 2. Primary water flow and return connections | 8. Removable combustion chamber plate |
| 3. Flue connection | 9. Heat exchanger |
| 4. Primary circuit | 10. Removable front panel |
| 5. Combustion chamber | 11. Control panel |
| 6. Primary drain connection | |

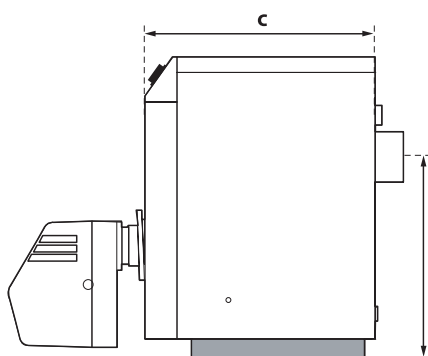
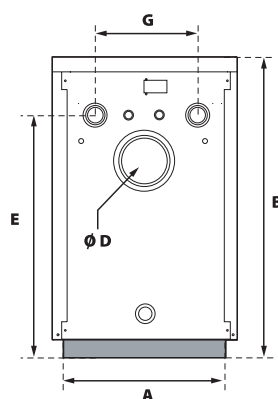

	A mm	B mm	C mm	D Ø mm	E mm	F mm	G mm
N1	470	700	566	130	550	445	260
N2	470	765	566	130	615	510	260
N3	530	805	656	150	645	550	260

Flue system 80mm/125mm

Delta Performance FV/MV 35 Heatmaster 35TC Prestige 24/32



A TERMINALS

Code	Type
537d6196	Vertical terminal
537d6173	Horizontal terminal



B FLUE PIPE

Code	Type
537d6174	Length 250 mm
537d6175	Length 500 mm
537d6176	Length 1000 mm



C ADJUSTABLE FLUE PIPE

Code	Type
537d6177	500 mm adjustable length 325-400



D FLUE BENDS

Code	Type
537d6178	Bend 43°- 45°
537d6179	Bend 87°- 90°



E CONDENSATE RECOVERY AND GAS ANALYSER CONNECTOR

Code	Type
537d6180	Gas analyser with condensate recovery



F FLASHINGS AND BRACKETS

Code	Type
537d6181	Flat roof flashing
537d6182	Adjustable flashing
537d6183	Bracket 125 mm



Flue system 100mm/150mm

HeatMaster 85TC Prestige 50 & 75

A TERMINALS

Code	Type
537d6197	Vertical terminal
537d6198	Horizontal terminal

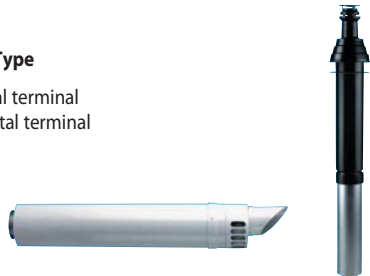

B FLUE PIPE

Code	Type
537d6199	Length 250 mm
537d6200	Length 500 mm
537d6201	Length 1000 mm



C ADJUSTABLE FLUE PIPE

Code	Type
537d6202	500 mm adjustable length 325-400



D FLUE BENDS

Code	Type
537d6203	Bend 43° - 45°
537d6204	Bend 87° - 90°



E CONDENSATE RECOVERY AND GAS ANALYSER CONNECTOR

Code	Type
537d6205	Condensate recovery device
537d6206	Gas analyser connector
537d6207	Adaptor 100/150 - 100/100



F FLASHINGS AND BRACKETS

Code	Type
537d6208	Flat roof flashing
537d6209	Adjustable flashing
537d6210	Bracket 150 mm



BSV 50

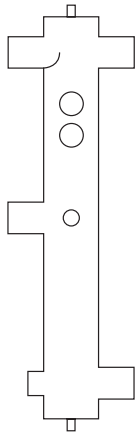

BSV 100

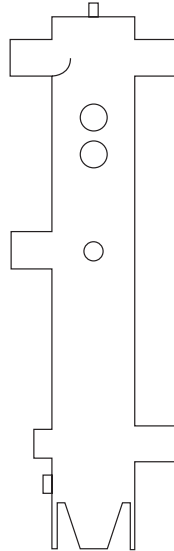

Balanced Header

Key advantages of the balanced header

- For easy connection of all types of ACV boilers to various primary circuits, up to 800kW
- Blends system return water to avoid cold return to boiler and reduce boiler cycling
- Traps sediment and other system debris so that boilers are not contaminated
- Drain point at bottom to facilitate sediment removal

BSV 150 & 200

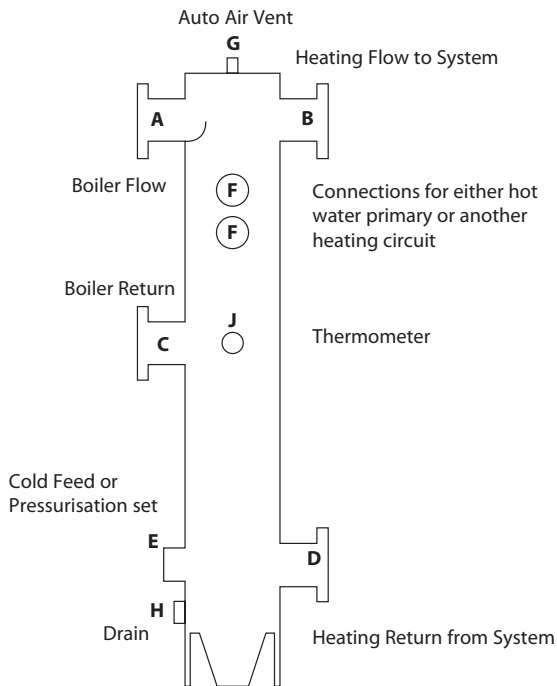

Connection Sizes

	BSV 50	BSV 100	BSV 150	BSV 200
A	Screwed 1.5" BSP (F)	Screwed 65	Flanged 80	Flanged 100
B	Screwed 1.5" BSP (F)	Screwed 65	Flanged 80	Flanged 100
C	Screwed 1.5" BSP (F)	Screwed 65	Flanged 80	Flanged 100
D	Screwed 1.5" BSP (F)	Screwed 65	Flanged 80	Flanged 100
E	Screwed 0.5" BSP (F)	Screwed 50	Screwed 50	Screwed 50
F	Screwed 1.0" BSP (F)	Screwed 50	Screwed 50	Screwed 50
G	Screwed 0.5" BSP (F)	Screwed 25	Screwed 25	Screwed 25
H	Screwed 0.5" BSP (F)	Screwed 25	Screwed 25	Screwed 25
J	Screwed 0.5" BSP (F)	Screwed 20	Screwed 20	Screwed 20

All dimensions in mm unless stated.

BSV 150 supplied with 3" table E and counter flanges (weld type).

BSV 200 supplied with 4" table E and counter flanges (weld type).



ACV International production facility
plus research & development centre in Seneffe, Belgium.



Stainless steel heat exchanger



Stainless steel cylinder

Stainless Steel Core

At the core of the Prestige and HeatMaster TC condensing units is an exclusive stainless steel heat exchanger, developed after intensive research and laboratory testing.

Similarly, a stainless steel cylinder is central to our well-proven Tank-in-Tank product range.

The use of stainless steel in ACV manufacturing provides unparalleled resistance to corrosion and the additives used in heating systems.



ACV UK Ltd

St. David's Business Park
Dalgety Bay, Fife KY11 9PF
Tel : 01383 820100
Fax : 01383 820180
information@acv-uk.com
www.acv-uk.com

Members of:

