



Yeoman Exe Midi

Conventional Flue Coal Effect Stove

With upgradeable control valve

Instructions for Use, Installation and Servicing

For use in GB, IE (Great Britain and Eire)

IMPORTANT

This product contains a Heat resistant glass panel. This panel should be checked during Installation and at each servicing interval. If any damage is observed on the front face of the glass panel (scratches, scores, cracks or other surface defects), the glass panel must be replaced and the appliance must not be used until a replacement is installed. Under no circumstances should the appliance be used if any damage is observed, the glass panel is removed or broken.

Parts of this appliance will become hot during operation; it is therefore recommended that a suitable guard should be used for protection of young children, the elderly or infirm.

This appliance is guaranteed for 2 years (subject to the conditions on page 3 of this Instruction manual). The second year of the guarantee will only be valid if the annual service recommended in this Instruction manual has been completed by a GasSafe registered engineer, and a copy of the service report is available for inspection by a Gazco engineer.

These Instructions must be left with the appliance for future reference and for consultation when servicing the appliance. Please make the customer aware of the correct operation of the appliance before leaving these instructions with them.

The commissioning sheet found on Page 3 of this Instruction manual must be completed by the Installer prior to leaving the premises.

CONTENTS

COVERING THE FOLLOWING MODELS:

YM-N9171FL / YM-N9171LC
YM-P9171FL / YM-P9171LC

	PAGE
APPLIANCE COMMISSIONING CHECKLIST	3
USER INSTRUCTIONS	4
INSTALLATION INSTRUCTIONS	9
Technical Specification	9
Site Requirements	10
Installation	11
Commissioning	14
SERVICING INSTRUCTIONS	15
Servicing Requirements	15
Fault Finding	15
How to replace parts	17
Basic spare parts list	21

APPLIANCE COMMISSIONING CHECKLIST

IMPORTANT NOTICE

Explain the operation of the appliance to the end user and hand the completed instructions to them for safe keeping as the information will be required when making any guaranteed claims.

FLUE CHECK	PASS	FAIL	
1. Flue is correct for appliance			
2. Flue flow test			
3. Spillage test			
GAS CHECK			
1. Gas soundness & let by test			
2. Standing pressure test	mb		
3. Appliance working pressure (on High Setting) NB All other gas appliances must be operating on full	mb		
4. Gas rate	m ³ /h		
5. Does ventilation meet appliance requirements			
6. Have controls been upgraded (Upgradeable models only)	8455 Standard	YES	NO
	8456 Programmable Thermostatic and Timer	YES	NO

RETAILER AND INSTALLER INFORMATION

Retailer

Gas Type

.....

Installation Company

.....

Contact No.

.....

Date of Purchase

Engineer

Model No.

Contact No.

Serial No.

Gas Safe Reg No.

Date of Installation

This product is guaranteed for 2 years from the date of installation, as set out in the terms and conditions of sale between Gazco and your local Gazco retailer. **This guarantee will be invalid, to the extent permitted by law, if the above Appliance Commissioning Checklist is not fully completed by the installer and available for inspection by a Gazco engineer.** The guarantee will only be valid during the second year, to the extent permitted by law, if the annual service recommended in the Instructions for Use has been completed by a Gas Safe registered engineer, and a copy of the service visit report is available for inspection by a Gazco engineer.

USER INSTRUCTIONS

1. GENERAL

In the event of a gas escape, or if you can smell gas, please take the following steps:

- Immediately turn off the gas supply at the meter/emergency control valve.
- Extinguish all sources of ignition.
- Do not smoke.
- Do not operate any electrical light or power switches (On or Off).
- Ventilate the building(s) by opening doors and windows.
- Ensure access to the premises can be made.

Please report the incident immediately to the National Gas Emergency Service Call Centre on 0800 111 999 (England, Scotland and Wales) 0800 002 001 (N. Ireland) or in the case of LPG, the gas supplier whose details can be found on the bulk storage vessel or cylinder.

The gas supply must not be used until remedial action has been taken to correct the defect and the installation has been recommissioned by a competent person.

- 1.1 Installation and servicing must only be carried out by a competent person whose name appears on the Gas Safe register. To ensure the engineer is registered with Gas Safe they should possess an ID Card carrying the following logo:



- 1.2 This appliance is suitable for use in G.B. and I.E. using Natural Gas at a supply pressure of 20mbar or LPG at a supply pressure of 29mbar (Butane) or 37mbar (propane).
- 1.3 The installation shall also be completed in accordance with:
— The Building Regulations issued by The Department of The Environment.
— The Building Standards (Scotland) Regulations issued by the Scottish Development Department.
— For Republic of Ireland, reference should be made to the relevant standards governing installations (IS813:1996).
- 1.4 Read all these instructions before commencing installation.
- 1.5 This appliance must be installed in accordance with the rules in force and only used in a sufficiently ventilated space.
- 1.6 Ensure that curtains are not positioned above the stove, and that there is a clearance of at least 300mm between the sides of the stove and any curtains.

- 1.7 The manufacturer considers the full outer casing of this stove to be a working surface which becomes hot when the stove is lit. A suitable guard is recommended to protect young children, the aged and the infirm.
- 1.8 This stove must only be operated with the door secured firmly in position. If any cracks appear in the glass the appliance must not be used until the glass panel is replaced.
- 1.9 Do not attempt to burn rubbish in this stove.
- 1.10 Do not hang curtains above the stove. You must leave 300mm (1') clearance between the stove and any curtains at either side.
- 1.11 Any combustible shelves or surrounding furniture must be fitted in accordance with the minimum dimensions detailed in Diagram 1.

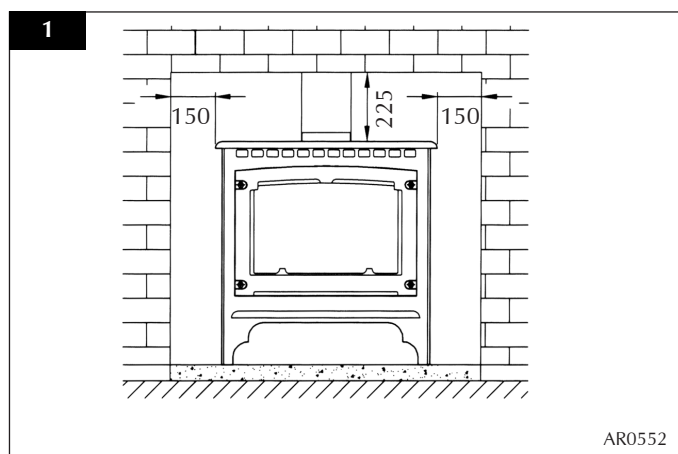

- 1.12 Following home improvements carried out after installation of this stove (e.g. the fitting of double glazing) contact a competent service engineer to carry out relevant spillage checks etc.
- 1.13 Quote the Model and Serial Number found on the data badge at the back of the stove in all correspondence.
- 1.14 This product is guaranteed for 2 years from the date of installation, as set out in the terms and conditions of sale between Gazco and your local Gazco retailer. Please consult your Gazco retailer if you have any questions. In all correspondence always quote the model no. and serial no. **Please ensure the commissioning checklist is completed by your installer as this is a requirement of your Guarantee.**

USER INSTRUCTIONS

2. LIGHTING THE STOVE

- 2.1 The control valve is on the right-hand side at the foot of the stove. It has two controls:
- The right-hand knob controls the pilot ignition
 - The left-hand knob controls the main burner
- 2.2 Refer to separate instructions if your stove is upgraded to include battery remote control. The following instructions apply whether or not you have the remote upgrade.

Lighting the Pilot

- 2.3 The left-hand and right-hand control knobs must both point to off (●):

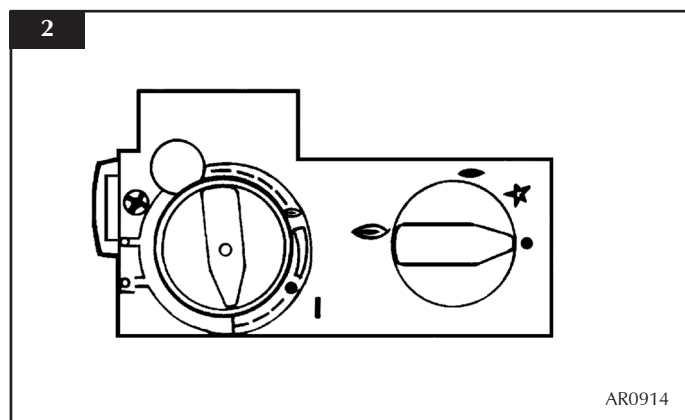

- 2.4 Press in the right-hand control knob and rotate anti-clockwise until a click is heard.
- 2.5 Continue to press in. The knob should point to the pilot (☛). The pilot should now light.
- 2.6 Keep the knob depressed for 10 seconds before releasing. The pilot should remain lit.
- 2.7 If the pilot does not stay lit repeat the above steps.

NOTE: If the pilot goes out the Interlock system prevents it being lit again for a short period.

- 2.8 If, after repeating the above steps, the pilot does not light, contact your retailer or installer.

Adjusting the Flame height

- 2.9 Turn the right hand control to point to main burner (☛). You can now adjust the flame height and temperature using the left-hand control knob.
- 2.10 Turn the left-hand knob anti-clockwise to increase the flame height.
- 2.11 Turn clockwise to decrease the height.

YELLOW FLAMES APPEAR WHEN THE STOVE HAS REACHED SUFFICIENT HEAT (10 TO 20 MINUTES). IF THE STOVE IS EXTINGUISHED OR GOES OUT DURING USE WAIT 3 MINUTES BEFORE ATTEMPTING TO RELIGHT.

3. TURNING THE STOVE OFF

- 3.1 To turn off main burner turn the **left-hand** knob until it points to off (●). The pilot light will remain lit.
- 3.2 To turn off pilot light press in and turn the **right-hand** knob until it points to off (●). The pilot light will go out.

4. UPGRADING THE STOVE

The stove is fitted with a control valve that can be upgraded to support a battery powered remote control. Two types of remote control can be obtained through your local Gazco stockist:

- 4.1 The **Standard Remote Control (Gazco Part No. 8455)** controls the gas stove after the pilot is lit so you can regulate the main burner through its range of settings and turn the burner off leaving just the pilot lit.
- 4.2 The **Thermostatic and Timer Remote Control (Gazco Part No. 8456)** controls the stove after the pilot is lit using three modes:
- Manual Mode – used to turn the burner on and off and regulate it through its range of settings.
 - Auto Mode – used to turn the burner on and off and regulate the heat to a pre-set temperature.
 - Timer Mode – used to turn the burner on and off at two pre-set times and regulate the heat to a pre-set temperature during those periods.

USER INSTRUCTIONS

5. CLEANING THE STOVE

Advice on Handling and Disposal of Fire Ceramics

- 5.1 The fuel effect logs and embers in this stove are made from Refractory Ceramic Fibre (RCF). Protective clothing is not required when handling these articles, but we recommend you follow normal hygiene rules of not smoking, eating or drinking in the work area and always wash your hands before eating or drinking. Excessive exposure to these materials may cause temporary irritation to eyes, skin and respiratory tract; wash hands thoroughly after handling the material.
- 5.2 To ensure that the release of RCF fibres is kept to a minimum a HEPA filtered vacuum is recommended to remove any dust accumulated in and around the stove.
- 5.3 When servicing the stove it is recommended that the replaced items are not broken up, but are sealed into heavy duty polythene bags and labelled as RCF waste. RCF waste is classed as stable, non-reactive, hazardous waste and may be disposed of at a licensed landfill site.
- 5.4 After cleaning the stove or replacing parts, carefully re-assemble the ceramic components.

WARNING: NEVER CLEAN THE STOVE WHILE IT IS HOT. THE STOVE STAYS HOT LONG AFTER USE.

- 5.5 Make sure the stove and surrounds are cool before trying to clean.
- 5.6 Turn and pull right hand rose to open door (see Diagram 3).

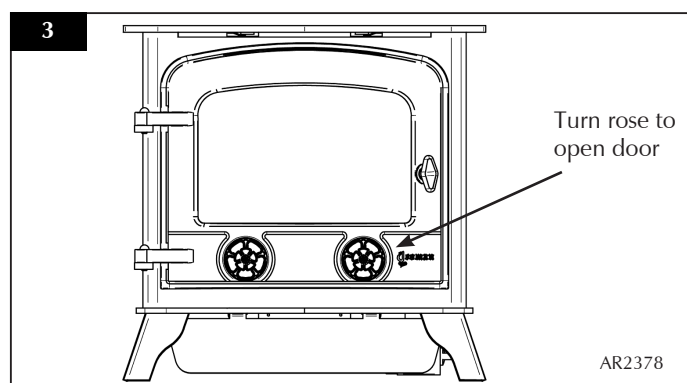

- 5.7 Remove the glass frame by undoing the 6 x frame fixing screws and lifting clear (see Diagram 4).

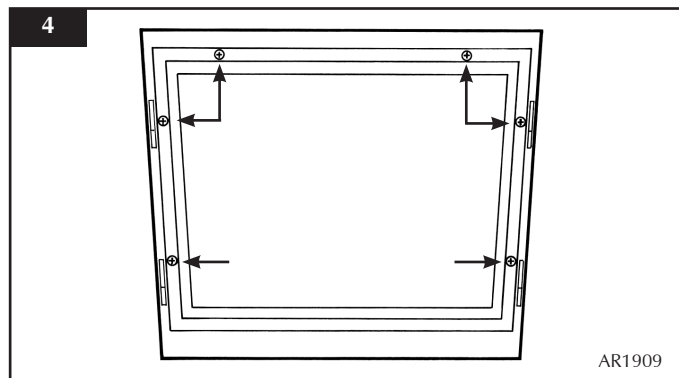

- 5.8 Carefully remove the ceramic fuel bed components and place to one side, taking care to protect floor coverings etc.

PLEASE HANDLE WITH CARE

- 5.9 The coals should not require cleaning. Do not use a vacuum cleaner or brush to clean the coals, any large pieces of debris may be removed by hand.
- 5.10 Ensure any debris is removed from the burner ports.
- 5.11 Replace the ceramics by referring to Section 6.
- 5.12 Use a damp cloth to clean the outer casing of the appliance.

USER INSTRUCTIONS

6. FUEL BED ARRANGEMENT

- 6.1 Place the flame baffle onto the burner and push against the rear tray lip (see Diagram 5).

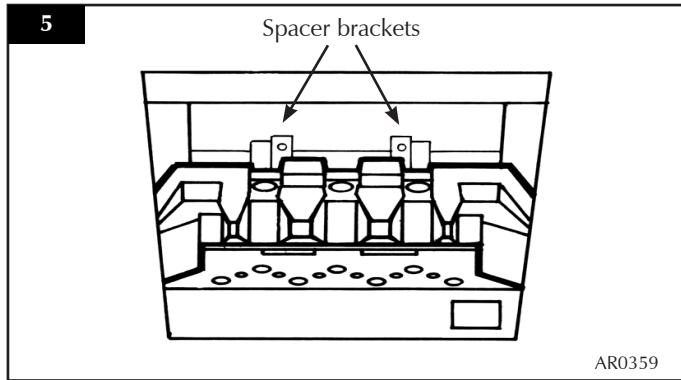

- 6.2 Locate the rear panel against the spacer brackets (see Diagram 3) and slide down so that it locates on the ledge of the flame baffle (see Diagram 6).

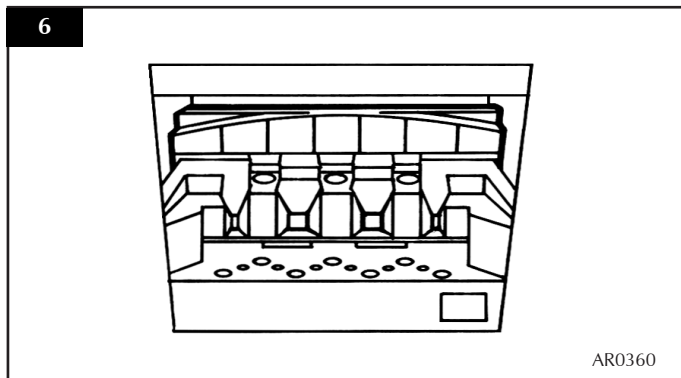

- 6.3 Place the log retainer in the two guides as shown in Diagram 7.

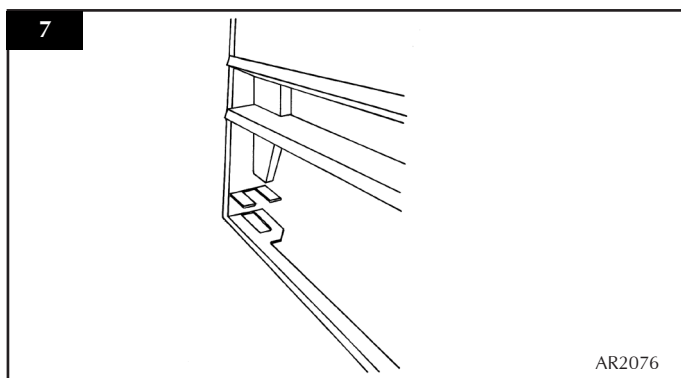

FOR CLARITY, THE FOLLOWING LOG ARRANGEMENT DIAGRAMS DO NOT INCLUDE ILLUSTRATION OF THE RETAINER.

- 6.4 Locate the front coal between the heat shield and the flame baffle so that the ends sit flat against the burner skin (see Diagram 8).

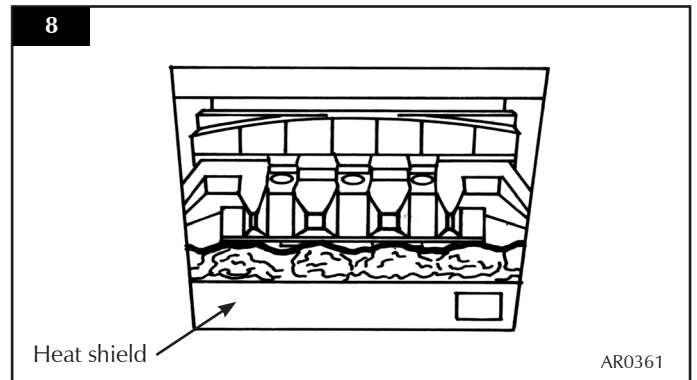

- 6.5 Place five of the loose round coals on the front coal so they lean against the flame baffle, in between the fingers. Place the two rectangular coals against the reflector panels, one either side, behind the front row of loose coals (see Diagram 9).

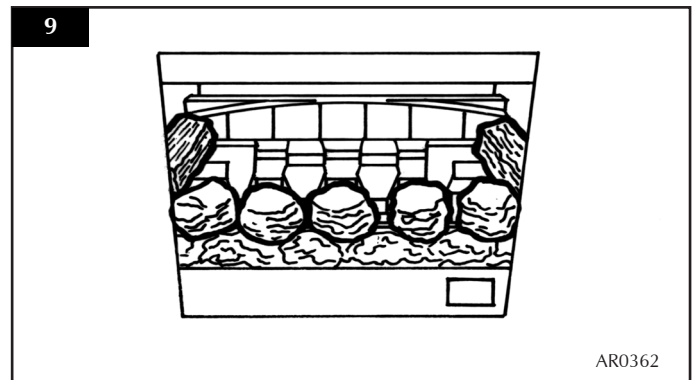

- 6.6 Place four of the loose round coals behind the first row so that they sit on the fingers of the flame baffle, the two outer ones should touch the rectangular coals (see Diagram 10).

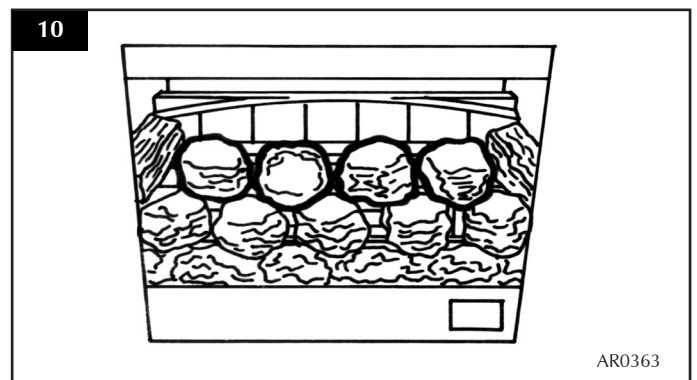

- 6.7 Place the remaining three round coals behind the centre row so that they touch the back panel (see Diagram 11).

USER INSTRUCTIONS

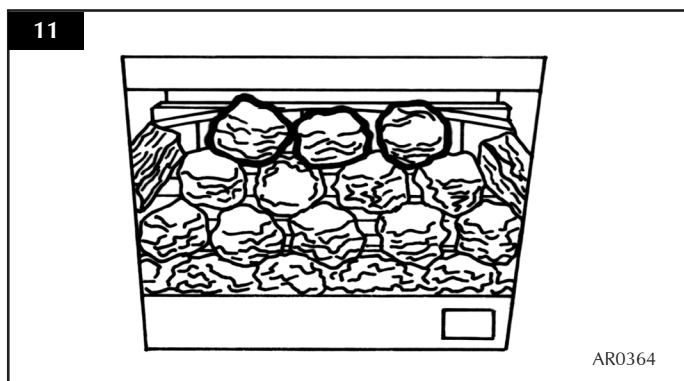

- 6.8 Replace the glass frame using the 6 x frame fixing screws (see Diagram 4) and close door.

7. GAZCO FLUE SURE SYSTEM

The stove is fitted with the Gazco Flue Sure System, which will act to cut off the gas supply to the burners in the event of incorrect operation of the flue. If the system acts to cut off the gas supply, this indicates that there is insufficient flue pull. If this occurs a minimum of 10 minutes should be allowed before trying to relight. Continued operation of this safety device means there may be a serious problem with the flue system. A qualified gas engineer should inspect this.

Do not use the stove until an engineer says it is safe to do so.

8. FLAME FAILURE DEVICE

This is a safety feature of all Gazco stoves which automatically switches off the gas supply should the pilot go out.

9. RUNNING IN

The surface coating of your Gazco stove burns off during the first few hours of use, producing a harmless temporary odour. This disappears after a short period, but if it persists, ask your retailer for advice.

10. SERVICING

A qualified gas engineer must service the stove every 12 months. In all correspondence, always quote the Model and Serial Number found on the data badge at the back of the stove.

11. VENTILATION

Any purpose provided ventilation should be checked periodically to ensure that it is free from obstruction.

12. INSTALLATION DETAILS

Make sure your installer completes the *Appliance Commissioning Checklist* on page 3. This records essential details of this stove. In all correspondence, always quote the Model and Serial Number.

13. HOT SURFACES

This stove becomes hot during normal use. You must use a suitable fire guard to protect children, the elderly and the infirm.

INSTALLATION INSTRUCTIONS

TECHNICAL SPECIFICATION

Covering the following models:

Yeoman Exe Midi

YM-N9171FL / YM-N9171LC
 YM-P9171FL / YM-P9171LC

Model	Gas CAT.	Gas Type	Working Pressure	NOX Class	Aeration	Injector	Gas Rate m ³ /h	Input kW (Gross)		Country
								High	Low	
Yeoman Exe Midi YM-N9171FL/LC	I _{2H}	Natural Gas G20	20 mbar	5	1 x 7.5mm	260	0.435	4.6 Gross	2.5 Gross	GB, IE
Yeoman Exe Midi YM-P9171FL/LC	I _{3P}	LPG Propane G31	37 mbar	5	1 x 13.5mm	110	0.170	4.4 Gross	2.3 Gross	GB, IE
Efficiency Class II Flue Outlet Size 127mm (5") ø Gas Inlet Connection Size 8mm ø										
Minimum flue specification		T260 / N2 / O / D / 1								
Maximum flue temperature		180°C								

PACKING CHECKLIST

- 1 x Stove
- 1 x Flue infill plate
- 1 x Front coal
- 1 x Flame baffle
- 1 x Coal set
- 1 x Rear ceramic
- 1 x Fixing kit containing:
- 1 x Instruction manual
- 2 x Wood screws
- 2 x Wall plugs
- 1 x Hexagon key

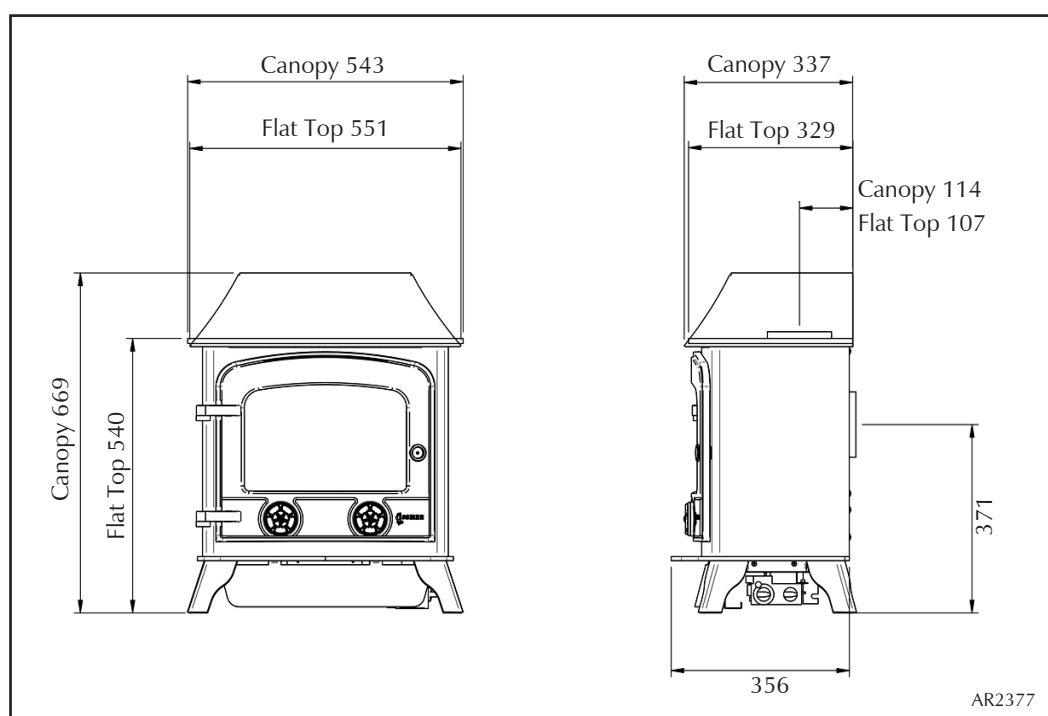

INSTALLATION INSTRUCTIONS

SITE REQUIREMENTS

1. FLUE AND CHIMNEY REQUIREMENTS

- 1.1 The chimney or flue system must comply with the rules in force, and must be a minimum of 127mm (5") in diameter.
- 1.2 The minimum effective height of the flue or chimney must be 3 metres (10ft). Any horizontal flue run from the rear outlet should not exceed 100mm from the back of the appliance.
- 1.3 The chimney or flue must be free from any obstruction. Any damper plates should be removed or secured in the fully open position, and no restrictor plates should be fitted.
- 1.4 The chimney should be swept prior to the installation of the appliance. However, where it can be seen that the chimney is clean and unobstructed throughout its entire length, it need not be swept.
- 1.5 If the stove is to be fitted into an existing brick built chimney without a closure plate, a 127mm (5") liner must be used. Larger lined flues may work, but in some instances could cause cold start flue problems resulting in nuisance shutdown. Lined flues above 175mm (7") are not recommended.
- 1.6 Due to recent changes to European chimney standards, new flues and chimneys are now classified by their resistance to temperature, pressure, corrosion, condensation and fire. To assist in identifying the correct flue system, the minimum flue specification is shown in *Installation Instructions, Technical Specification* (page 8). Existing chimneys are not covered by this system.

2. VENTILATION

- 2.1 Consult the rules in force.
Note: This appliance does not normally require any additional ventilation when installed in G.B.

3. INSTALLATION OF THE GAS SUPPLY

- 9.1 Before installation ensure the stove is compatible with the local gas type and pressure.
- 9.2 Ensure the gas supply delivers the required amount of gas in accordance with the rules in force.
- 9.3 Soft copper tubing and soft soldered joints must be no closer than 50mm to the base of the burner unit.
- 9.4 Ensure a means of isolating the gas supply, **independent of the stove's controls** is provided.
- 9.5 All gas supply pipes must be purged of any debris before connection to the stove.

4. LOCATION

- 4.1 This appliance must stand on a non-combustible hearth that is at least 12mm thick, and projects a minimum of 50mm from the base of the stove in all directions (see Diagram 1).

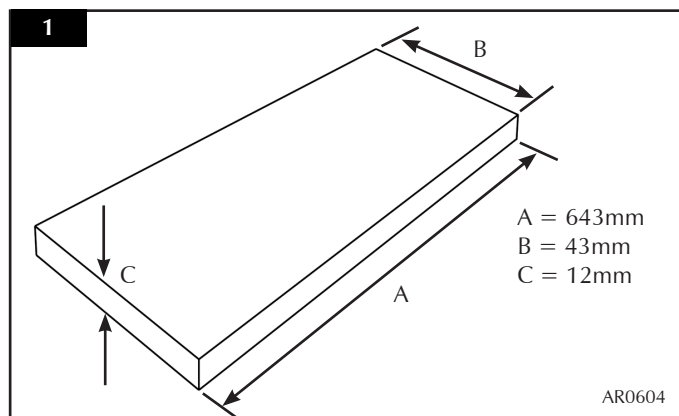

- 4.2 This appliance must not be installed in a room that contains a bath or shower.
- 4.3 The stove is not suitable for installation against a combustible wall; all combustible materials must be removed from the area behind the stove.
- 4.4 Ensure that all minimum clearances to combustible materials are complied with (see Diagrams 2 & 3).

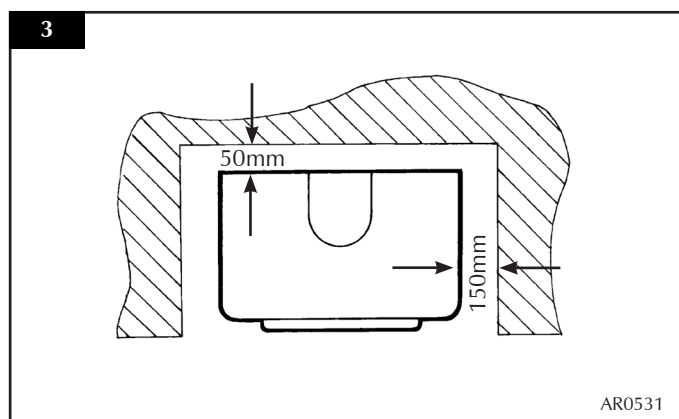
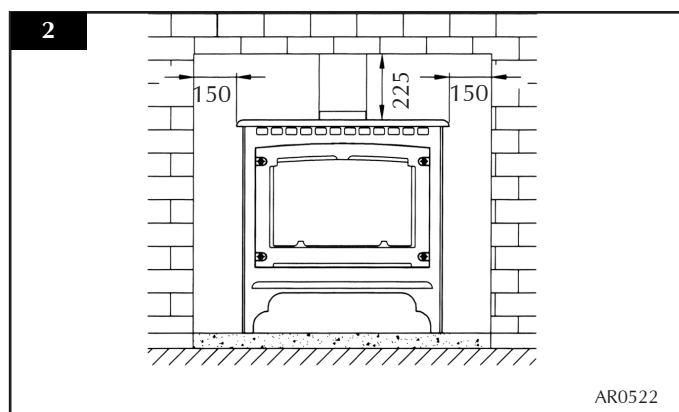

The above dimensions provide adequate clearance to combustible materials. It may be necessary to add additional clearance so that the controls can be reached and spillage tests performed when necessary.

INSTALLATION INSTRUCTIONS

INSTALLATION

IMPORTANT: ENSURE THAT THE APPLIANCE IS CORRECTLY ADJUSTED FOR THE GAS TYPE AND CATEGORY APPLICABLE IN THE COUNTRY OF USE. REFER TO DATA BADGE AND TECHNICAL SPECIFICATION AT THE FRONT OF THIS BOOKLET. FOR DETAILS ON CHANGING BETWEEN GAS TYPES REFER TO SECTION 11 PAGE 20 .

1. CONTROL UPGRADE

- 1.1 The stove is fitted with a control valve that can be upgraded to support a battery powered remote control. Two types of remote control can be obtained through your local Gazco stockist:
- 1.2 This upgrade can be fitted before or after installation but if side clearances are limited then it will be easier to upgrade the stove before installation. Full instructions are included with the kit.
- 1.3 The **Standard Remote Control (Gazco Part No. 8455)** controls the gas stove after the pilot is lit so you can regulate the main burner through its range of settings and turn the burner off leaving just the pilot lit.
- 1.4 The **Thermostatic and Timer Remote Control (Gazco Part No. 8456)** controls the stove after the pilot is lit using three modes:
 - Manual Mode – used to turn the burner on and off and regulate it through its range of settings.
 - Auto Mode – used to turn the burner on and off and regulate the heat to a pre-set temperature.
 - Timer Mode – used to turn the burner on and off at two pre-set times and regulate the heat to a pre-set temperature during those periods.

2. SAFETY PRECAUTIONS

- 1.1 This stove must be installed in accordance with the rules in force. Read these instructions before installing the stove.
- 1.2 All the instructions must be left, intact, with the user.
- 1.3 In the interests of your own and other's safety, this stove must be installed by a competent person according to local and national codes of practice. Failure to install the stove correctly could lead to prosecution.
- 1.4 This stove is for use on a governed gas installation and set to the required pressure.
- 1.5 Keep all plastic bags away from young children.
- 1.6 Do not place any object on or near the stove. Leave adequate clearance above the stove (see *Site Requirements, Diagram 2*).

- 2.7 The stove is fitted with the **Gazco Flue Sure System**, which will act to cut off the gas supply to the appliance in the event of incorrect operation of the flue. If the system acts to shut off the gas supply, this indicates that there is insufficient flue pull. If this occurs, a minimum of 10 minutes should be allowed before trying to relight. Continued operation of this safety device means that there may be a serious problem with the flue system; a qualified gas engineer should inspect this. **DO NOT USE THE STOVE UNTIL AN ENGINEER SAYS IT IS SAFE TO DO SO.**
- 2.8 The Flue Sure System must not be tampered with. Use only genuine Gazco replacement parts when servicing the system - refer to servicing section on page 14.

3. INSTALLATION OF THE STOVE

- 3.1 Open the carton, remove the accessory carton and stove unit. It will now be necessary to decide upon top or rear flue exit. The stove is factory built for rear flue exit but it may be changed to top exit by simply interchanging the flue spigot and blanking plate located on the stove.
- 3.2 Position the stove ensuring all appropriate clearances are observed. Using a pencil, mark the position of the holes in the fixing brackets attached to the inside of the rear legs.
- 3.3 Remove the stove and drill the holes using a number 12 masonry drill. Push wall plugs into the holes and insert the wood screws until the head is approximately 3mm proud of the hearth. Place the stove in position so that the screw heads are located in the large part of the slot in the bracket. Push the stove back so that the screw heads engage fully into the narrow part of the slot, tighten the screws as required.
- 3.4 Having run the gas supply to the stove, **PURGE THE SUPPLY PIPE**. This is essential to expel any debris that may block the gas controls. Connect the gas supply to the 8mm-compression elbow at the RH rear corner of the stove. There is a cutout in the RH rear leg to enable a direct straight connection to be made to the rear of the stove (see Diagram 4). A gas soundness check must be completed up to the gas inlet connection.

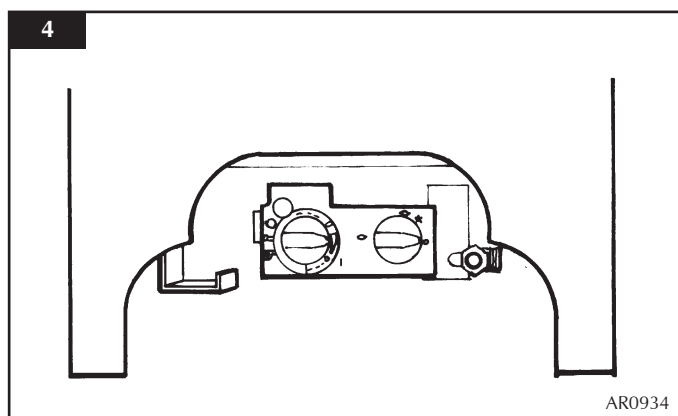

INSTALLATION INSTRUCTIONS

INSTALLATION

- 3.5 Check the pull of the flue system by applying a lighted smoke pellet to the flue system opening. If there is a definite flow into the chimney, proceed with the installation, if not warm the chimney for a few minutes.

IF THERE IS STILL NO DEFINITE FLOW, THE FLUE MAY REQUIRE ATTENTION - SEEK EXPERT ADVICE.

- 3.6 The flue system may now be connected to the stove, ensure that all joints are sealed with a suitable fire resistant sealant. It is also recommended that a physical retention method be used at the flue spigot joint, self-tapping screws being favoured.
- 3.7 Connect a suitable pressure gauge to the test point located on the inlet fitting, and turn the gas supply on. Light the appliance and check all gas joints for gas soundness. Turn the appliance to maximum and check that the supply pressure is as stated on the data badge. Turn the gas off and replace the test point screw, turn the gas on and check the test point for gas soundness.

4. FUEL BED ARRANGEMENT

ADVICE ON HANDLING AND DISPOSAL OF FIRE CERAMICS

- 4.1 The fuel effect logs and embers in this stove are made from Refractory Ceramic Fibre (RCF). Protective clothing is not required when handling these articles, but we recommend you follow normal hygiene rules of not smoking, eating or drinking in the work area and always wash your hands before eating or drinking. Excessive exposure to these materials may cause temporary irritation to eyes, skin and respiratory tract; wash hands thoroughly after handling the material.
- 4.2 To ensure that the release of RCF fibres is kept to a minimum a HEPA filtered vacuum is recommended to remove any dust accumulated in and around the stove.
- 4.3 When servicing the stove it is recommended that the replaced items are not broken up, but are sealed into heavy duty polythene bags and labelled as RCF waste. RCF waste is classed as stable, non-reactive, hazardous waste and may be disposed of at a licensed landfill site.
- 4.4 Turn and pull right hand rose to open door (see Diagram 5).

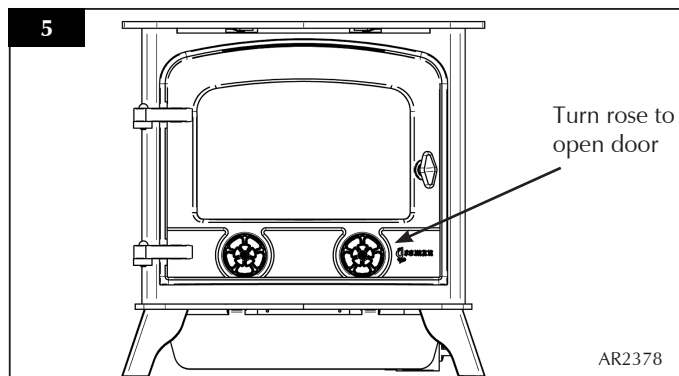

- 4.5 Remove the glass frame by undoing the 6 x frame fixing screws and lifting clear (see Diagram 6).

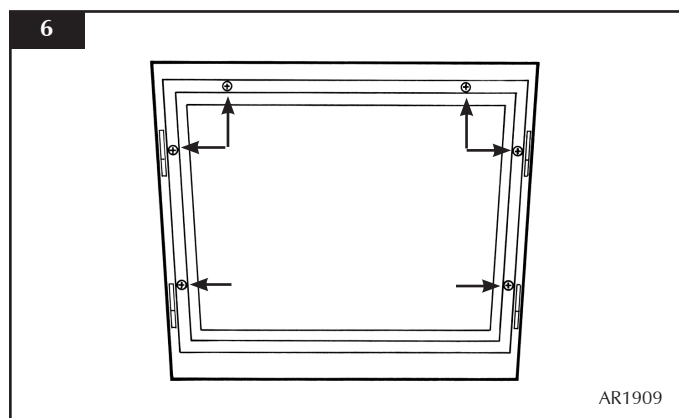

- 4.6 Place the flame baffle onto the burner and push up against the rear tray lip (see Diagram 7).

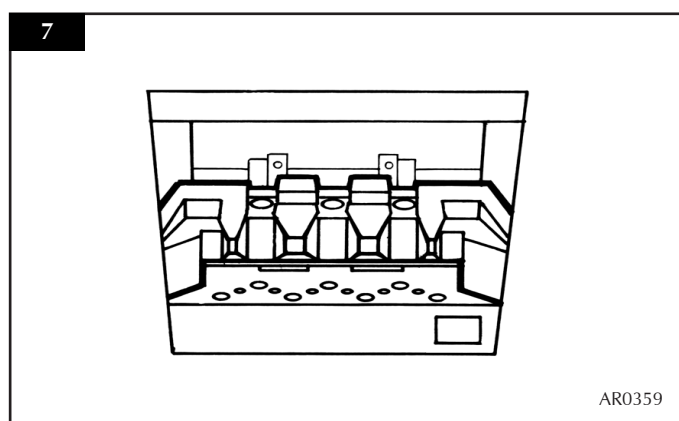

- 4.7 Locate the rear panel against the spacer brackets and slide down so that it locates on the ledge of the flame baffle (see Diagram 8).

INSTALLATION INSTRUCTIONS

INSTALLATION

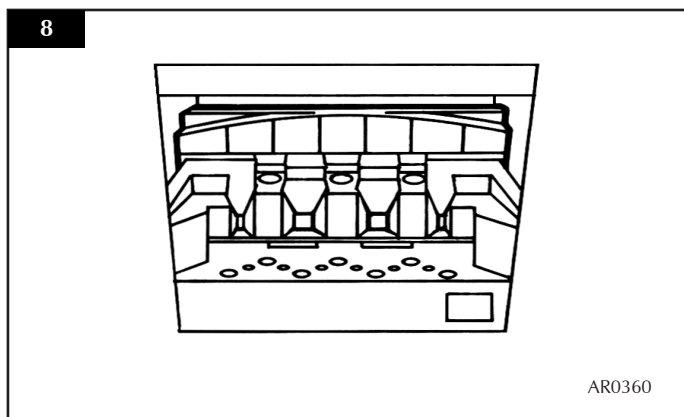

- 4.8 Place the log retainer in the two guides as shown in Diagram 9.

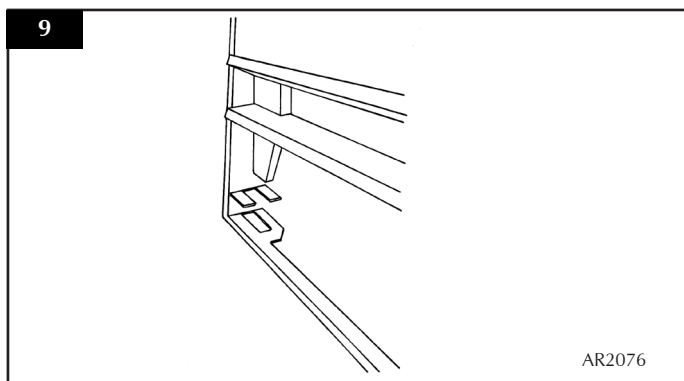

FOR CLARITY, THE FOLLOWING LOG ARRANGEMENT DIAGRAMS DO NOT INCLUDE ILLUSTRATION OF THE RETAINER.

- 4.9 Locate the front coal between the heat shield and the flame baffle so that the ends sit flat against the burner skin (see Diagram 10).

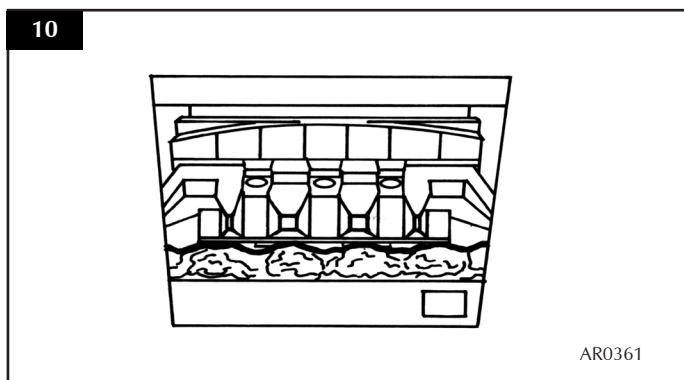

- 4.10 Place five of the loose round coals on the front coal so that they lean against the flame baffle, in between the fingers. Place the two rectangular coals against the reflector panels, one either side, behind the front row of loose coals (see Diagram 11).

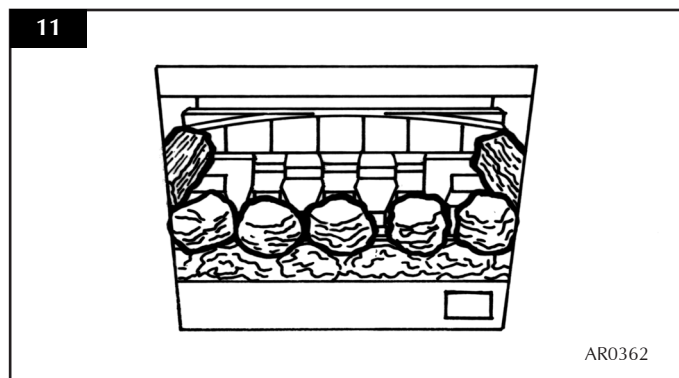

- 4.11 Place four of the loose round coals behind the first row so that they sit on the fingers, the two outer coals should touch the rectangular coals (see Diagram 12).

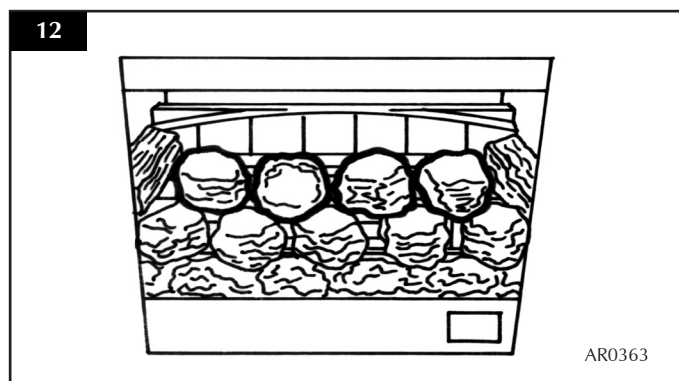

- 4.12 Place the remaining three coals behind the centre row so that they touch the back panel (see Diagram 13).

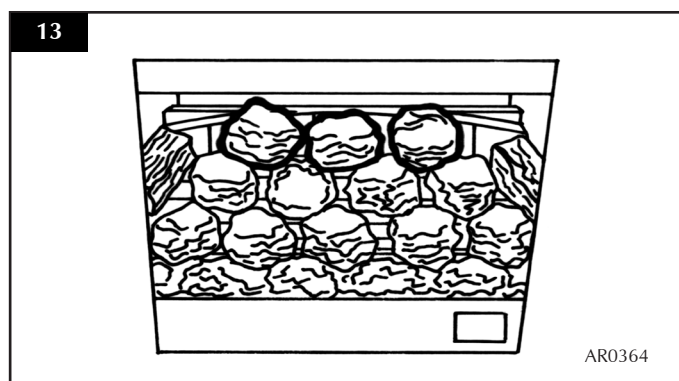

- 4.13 Replace the glass frame using the 6 x frame fixing screws (see Diagram 6) and close door.

5. LIGHTING THE STOVE

- 5.1 For full instructions see *User Instructions, Section 2*.

INSTALLATION INSTRUCTIONS

COMMISSIONING

1. COMMISSIONING

After connecting the gas pipe to the stove:

- 1.1 PURGE THE SUPPLY PIPE to dispel any debris that might block the controls.
- 1.2 Connect the gas supply to the 8mm compression elbow at the right-hand rear corner of the stove (see Diagram 1).

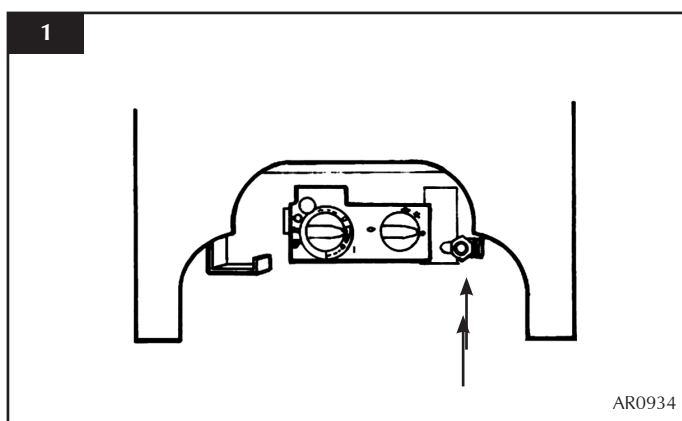

- 1.3 Connect a suitable pressure gauge to the test point on the inlet fitting.
- 1.4 Turn on the gas supply.
- 1.5 Light the stove and check all gas joints for leaks.
- 1.6 Turn the stove to maximum to check the supply pressure corresponds with the data badge information.
- 1.7 Turn the gas off.
- 1.8 Replace the test point screw.
- 1.9 Turn the gas on.
- 1.10 Check the test point for leaks.

To finish commissioning:

- 1.11 Check the stove complies with all local regulations.
- 1.12 Check all seals are in good condition.
- 1.13 Complete the *Appliance Commissioning Checklist* on page 3.
- 1.14 Show the user how to operate the stove.
- 1.15 Hand the completed instructions to the User for safe keeping. The information is required when making any guarantee claims.

SERVICING INSTRUCTIONS

SERVICING REQUIREMENTS/ FAULT FINDING CHARTS

1. SERVICING REQUIREMENTS

IMPORTANT – The glass panel on this appliance should be checked for any signs of damage on the front face of the glass panel (scratches, scores, cracks or other surface defects). If damage is observed, the glass panel must be replaced and the appliance must not be used until a replacement is installed. Under no circumstances should the appliance be used if any damage is observed. Please isolate the appliance until a replacement glass panel has been obtained and installed. Replacement glass panels can be purchased from Gazco via the retailer from which the appliance was purchased or any other Gazco distributor.

This appliance must be serviced at least once a year by a competent person. All tests must be serviced by best practice as described by the current Gas Safe recommendations.

- 1.1 Before any test are undertaken on the appliance, conduct a gas soundness test for the property to ensure that there are no gas leaks prior to starting work.
- 1.2 Before any tests are undertaken on the appliance it is also recommended to fully check the operation of the appliance.

- 1.3 Special checks:
 - Clean any lint or fluff from the pilot - pay particular attention to the aeration hole in the side of the pilot.
 - Clean away any fluff or lint from under the burner.
 - Check that the spark gap on the pilot is correct.
- 1.4 Correct any faults found during the initial tests and then re-commission the appliance conducting the usual safety checks.
- 1.5 Advise the customer of any remedial action taken.

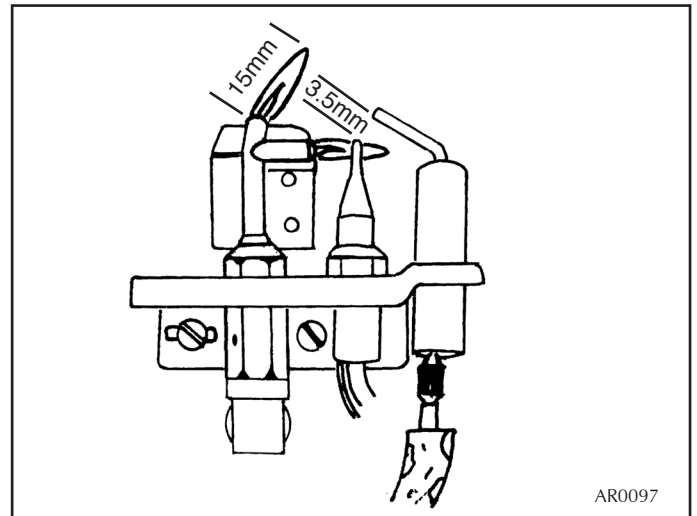

AR0097

IGNITION FUNCTIONAL CHECK 1

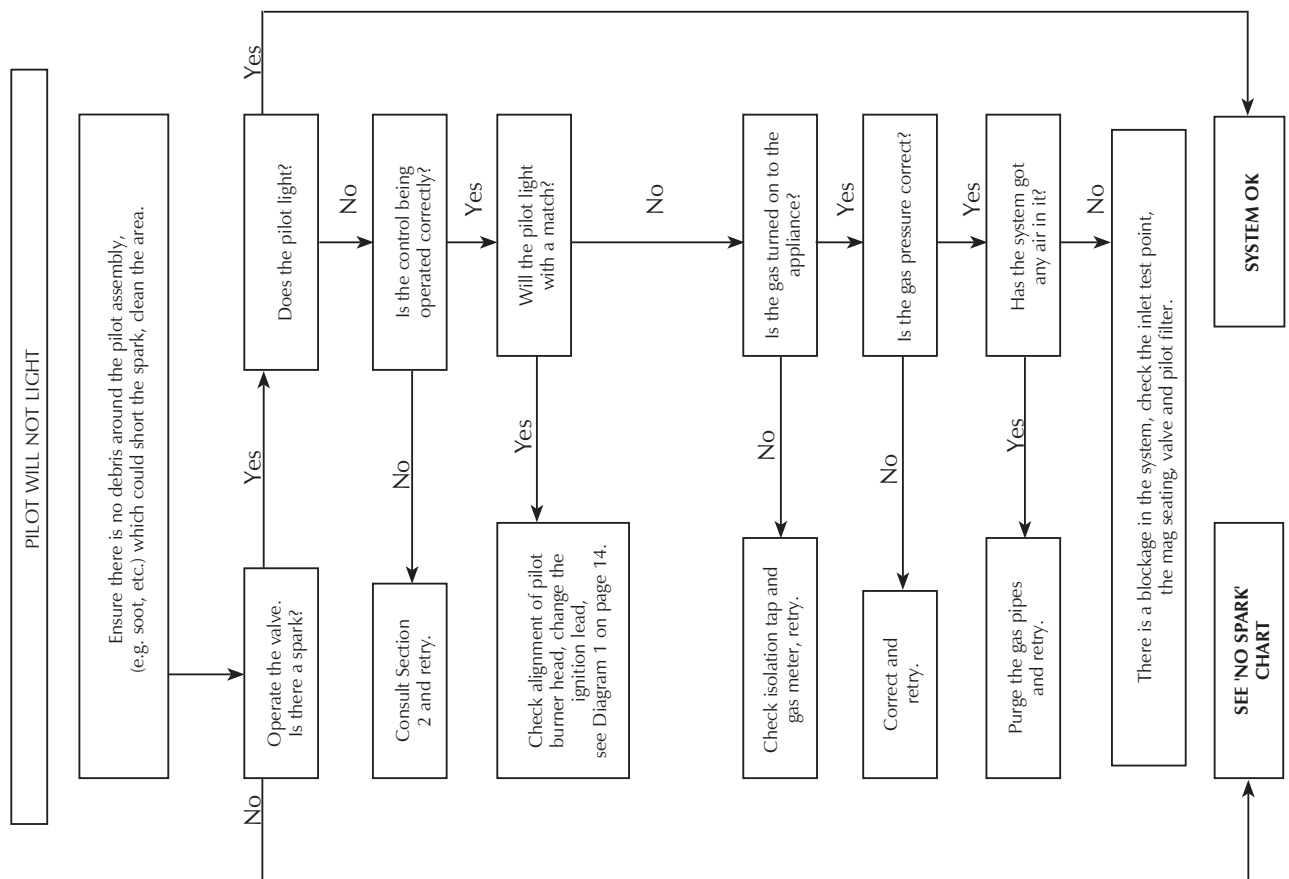

SERVICING INSTRUCTIONS

FAULT FINDING CHARTS

FLAME FAILURE FUNCTIONAL CHECK

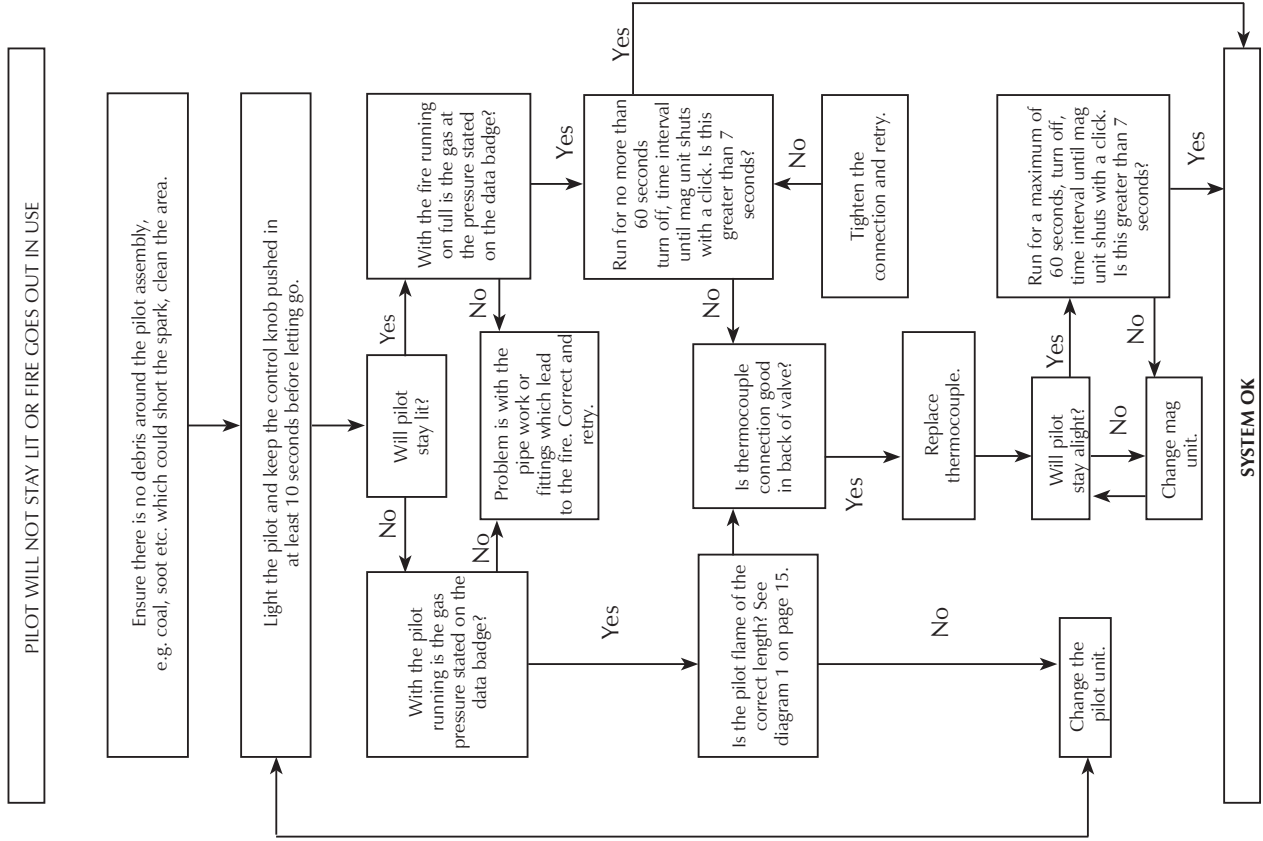

IGNITION FUNCTIONAL CHECK 2

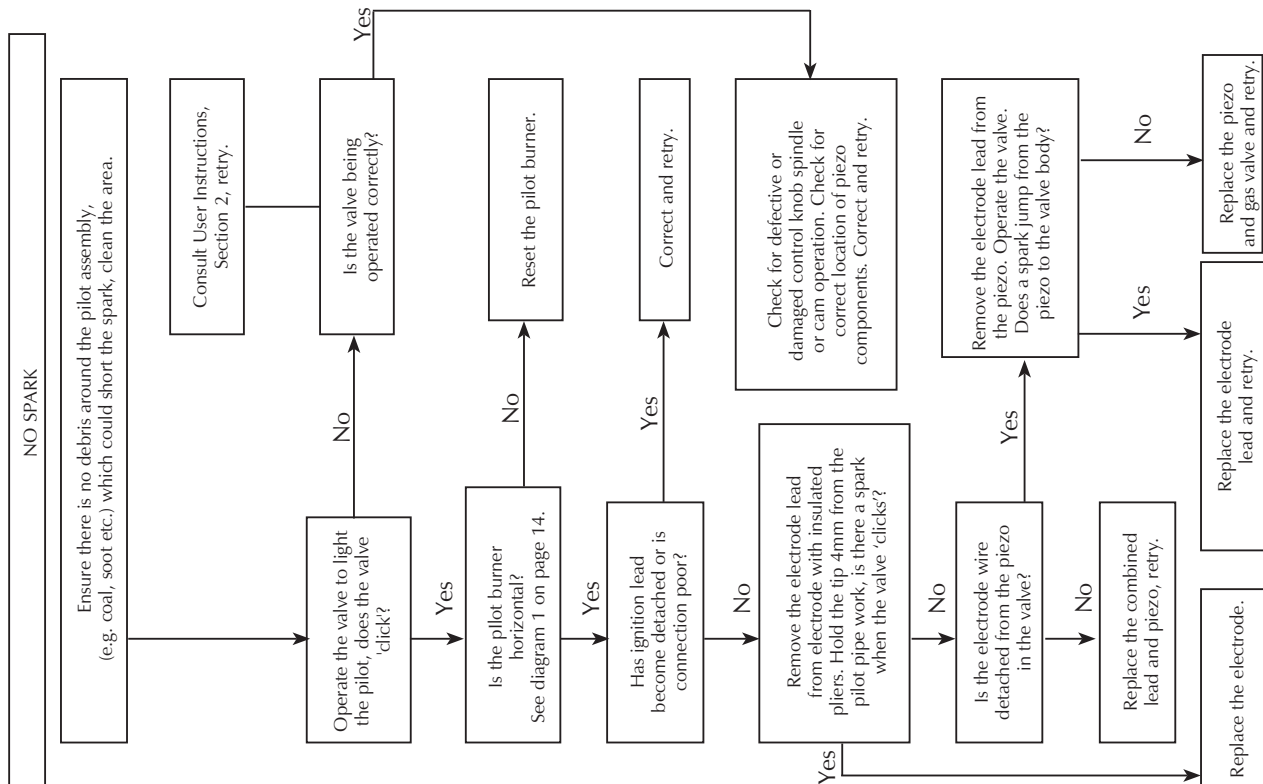

SERVICING INSTRUCTIONS

REPLACING PARTS

1. GENERAL

- 1.1 All main components can be replaced with the stove in place but it is essential to turn off the gas supply at the isolation device before proceeding. For information on the handling and disposal of fire ceramics please refer to *User Instructions, Section 5, Cleaning the Fire*.

ENSURE THE APPLIANCE IS COLD BEFORE STARTING WORK ON IT.

2. MAIN BURNER

- 2.1 Turn the gas supply off at the isolation device, remove the door and place to one side, and carefully remove the ceramic fuel bed components.
- 2.2 Remove the cover plate from the bottom of the stove by undoing the 6mm bolt, and place to one side (see Diagram 1).

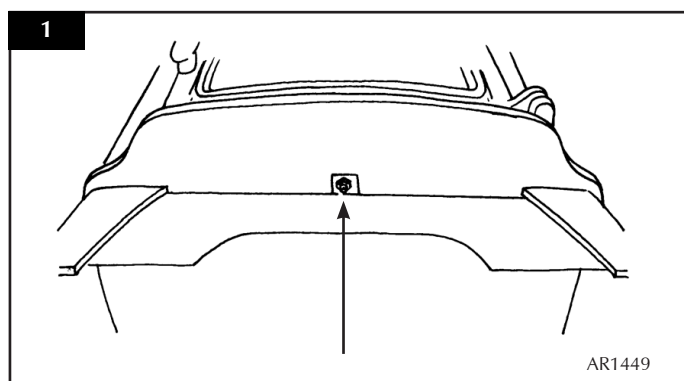

- 2.3 Disconnect the thermocouple from the gas valve (A) and remove the ignition lead from the electrode (B). Cut the cable tie if required, undo the compression nut (C) from the pilot unit and undo the compression nut on the injector (D) (see Diagram 2).

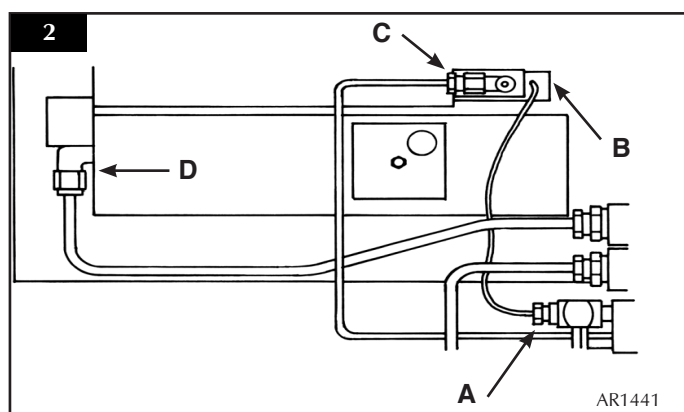

- 2.4 Remove the two screws at the back of the firebox and lift the burner unit clean (see Diagram 3).

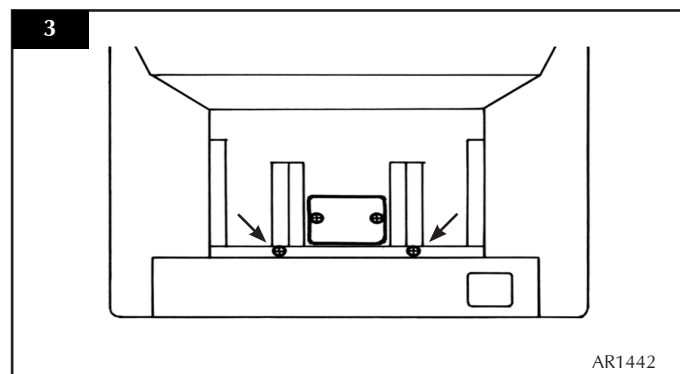

3. PILOT UNIT

- 3.1 Follow the procedure for removing the main burner (see Section 2) when the burner is removed from the stove, remove the aeration cover by undoing the two screws (see Diagram 4).

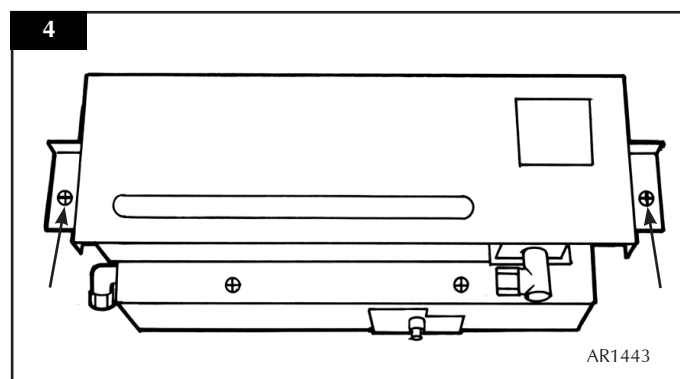

- 3.2 Remove the lint arrester by folding the tabs back (see Diagram 5).

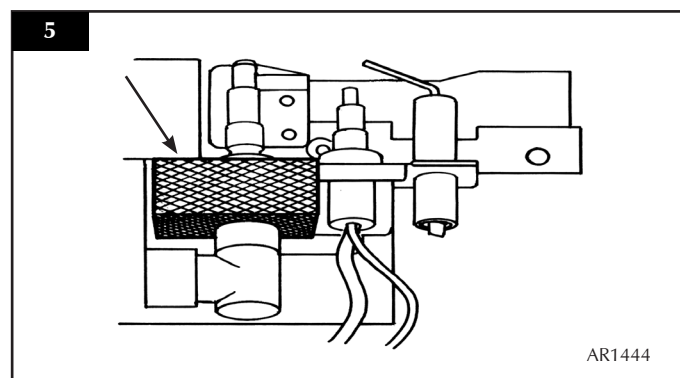

SERVICING INSTRUCTIONS

REPLACING PARTS

- 3.3 The pilot unit can now be removed by undoing the two screws (see Diagram 6).

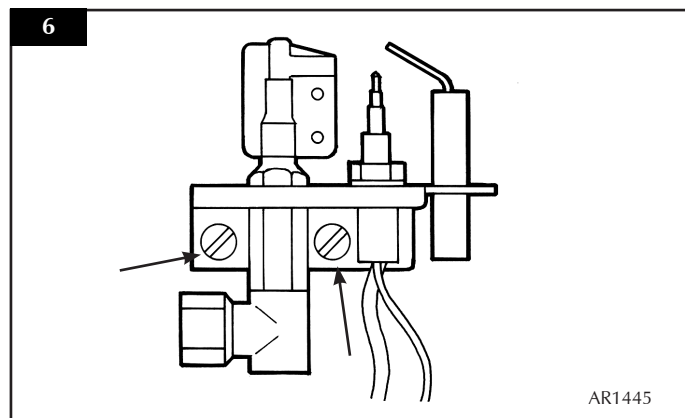

- 3.4 Reassemble in reverse order, do not overtighten.
NOTE: SPECIAL CARE SHOULD BE TAKEN WHEN REPLACING THE THERMOCOUPLE TO THE BACK OF THE GAS VALVE TO ENSURE THAT THE SENSOR WIRES FOR THE GAZCO FLUE SURE SYSTEM ARE NOT DISCONNECTED.

4. IGNITION LEAD AND PIEZO

- 4.1 Gain access to the back of the pilot assembly (see Section 2) and disconnect the ignition lead from the electrode.
- 4.2 Remove the front cover from the control valve (see Diagrams 7 and 8) and disconnect the other end of the ignition lead from the valve body. Note the existing route of the ignition lead.

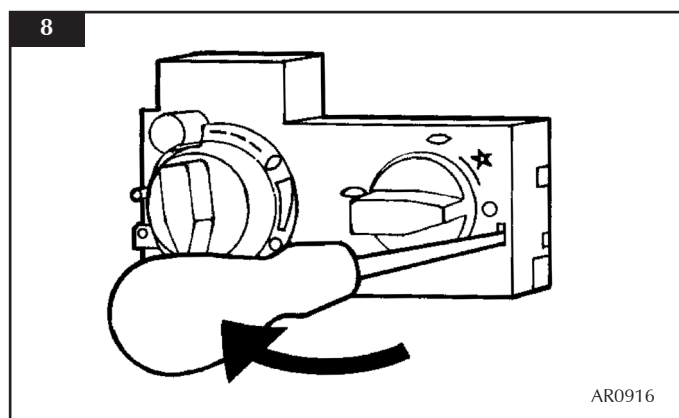
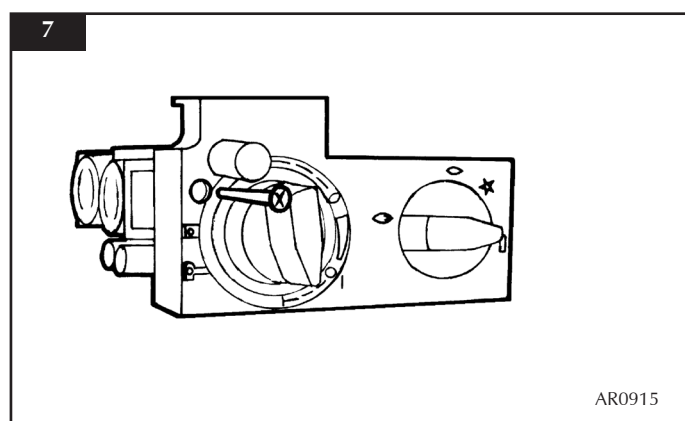

- 4.3 Replace with a new ignition lead following the same route as the old one. Replace the valve cover and the pilot assembly.
- 4.4 Check operation of the new ignition lead.

5. PIEZO

The piezo assembly used on this appliance is not serviceable and is unlikely to fail.

6. GAS VALVE

- 6.1 Turn the gas supply off at the isolation device.
- 6.2 Disconnect the 2 x 8mm and 1 x 4mm gas pipe fittings at the back of the gas valve (see Diagram 9, A) and disconnect the thermocouple (see Diagram 9, B).

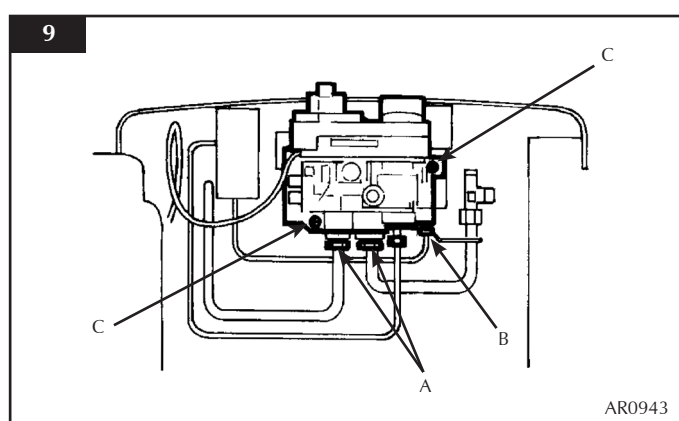

SERVICING INSTRUCTIONS

REPLACING PARTS

- 6.3 Undo the single screw that secures the left hand side of the control cover (see Diagram 10).

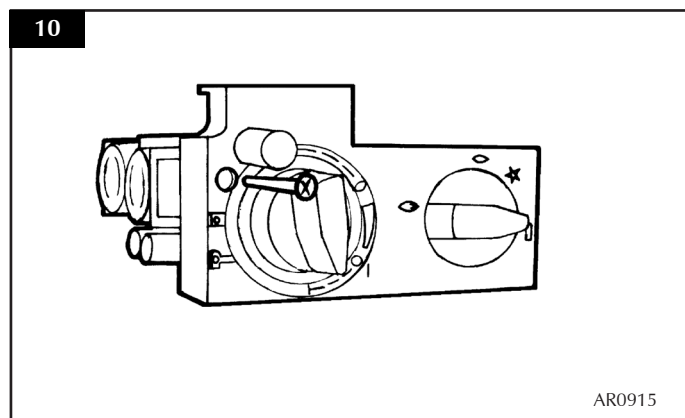

- 6.4 To release the right hand side of the control cover insert the narrow blade screwdriver into the slot shown in Diagram 11. Lever it gently and pull from the right hand side at the same time. The cover will now come off. There is a small cylindrical metal spacer inside the cover, this must be kept and replaced on the fixing screw during re-assembly.

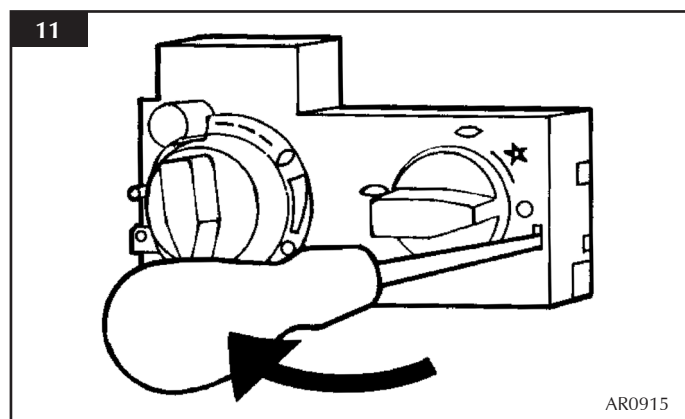

- 6.5 Disconnect the ignition lead from the gas valve.
- 6.6 Undo the two bolts (see Diagram 9, C) securing the gas valve to the appliance and remove the valve.
- 6.7 Replace in reverse order.
- 6.8 Check all joints for gas leaks and check operation of the thermocouple and ignition lead.

7. MAGNETIC SAFETY VALVE

- 7.1 Turn the gas supply off at the isolation device. Undo the thermocouple connection from the back of the gas valve, pull the sensor leads clear and remove the interrupter block (see Diagram 12, A).

- 7.2 Undo the magnetic valve-retaining nut from the back of the control valve, gently tap out the magnetic valve and replace with a new unit. Replace the retaining nut and tighten (see Diagram 12).

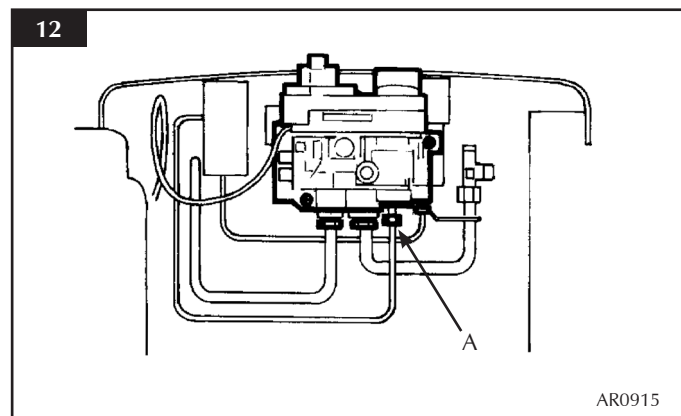

- 7.3 Reassemble the interrupter block and leads. Secure the thermocouple connection in the rear of the gas control. (Do not overtighten). Turn the gas supply on and check the entire pipe work and valve joints for any leaks.

8. MAIN INJECTOR

- 8.1 Turn the gas supply off at the isolation device and ensure that the appliance is cold before commencing work on it.
- 8.2 Undo the compression nut from the injector (A) and loosen the compression nut (B) in the gas valve body. Disconnect the pipe from the injector and unscrew the injector (C) from the burner unit (see Diagram 13).

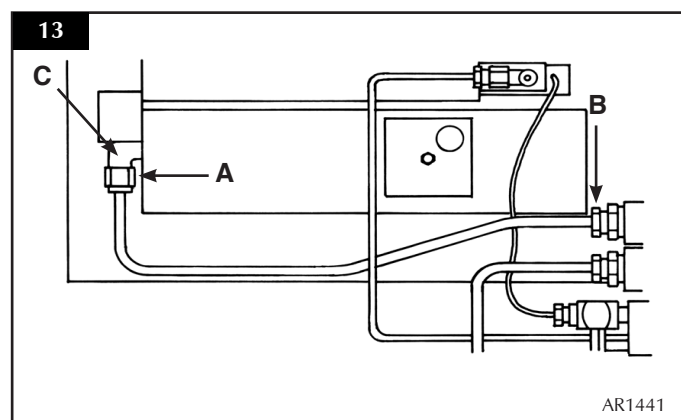

- 8.3 Reassemble in reverse order. The injector must **NOT** be tightened into the burner but be allowed to float to enable it to line up with the pipe. Turn on the gas supply and check for leaks.

SERVICING INSTRUCTIONS

REPLACING PARTS

9. GAZCO FLUE SURE SYSTEM

- 9.1 Open the door and remove the ceramics, placing them carefully to one side. Undo the two screws in the back of the firebox and carefully withdraw the bracket (see Diagram 14).

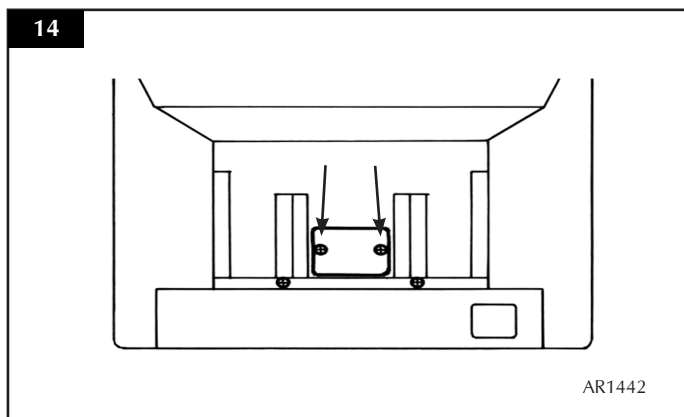

- 9.2 Disconnect the two sender wires. Undo the two tapite screws and remove the sensor and the two plastic spacers (see Diagram 15).

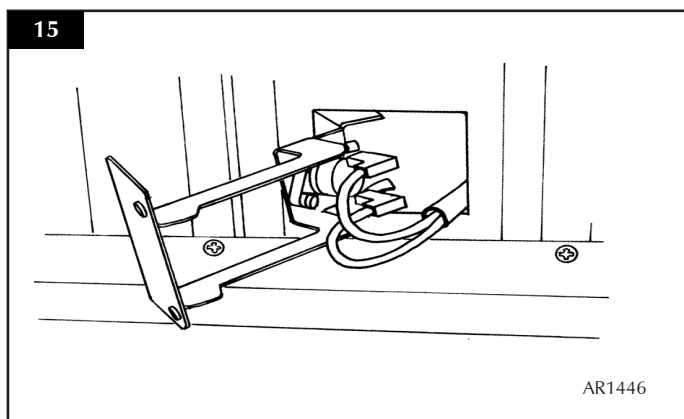

- 9.3 Refit the new sensor ensuring that the plastic spacers are located between the bracket and the sensor. Refit the leads (see Diagram 16).

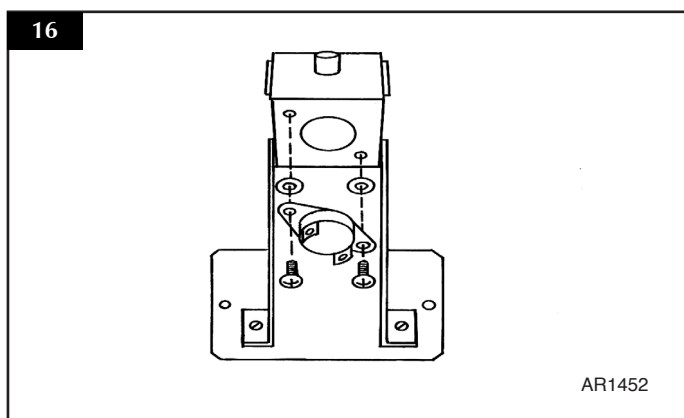

- 9.4 Feed the cable back through the hole as you replace the bracket. When the bracket is located correctly it will sit flush with the back panel without force being required. If not positioned correctly the bracket will sit at an angle (see Diagram 17).

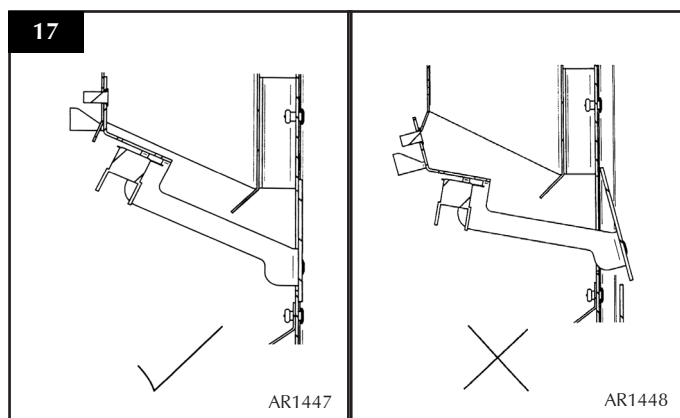

10. PRIMARY AERATION PLATE

- 10.1 Remove the cover plate from the bottom of the stove by undoing the 6mm bolt (see Diagram 18).

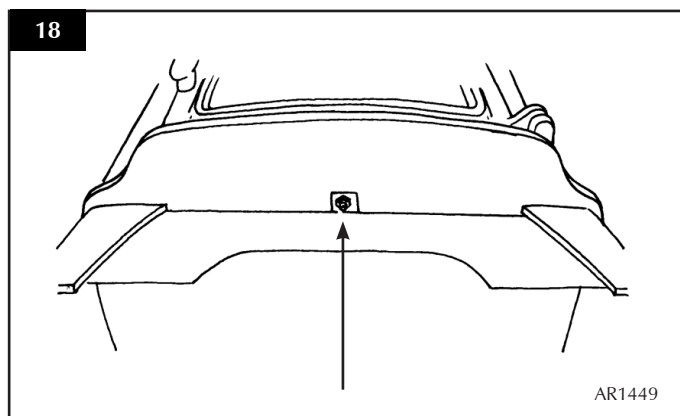

- 10.2 Undo the M5 nyloc nut from the bottom of the burner unit and remove the aeration plate (see Diagram 19).

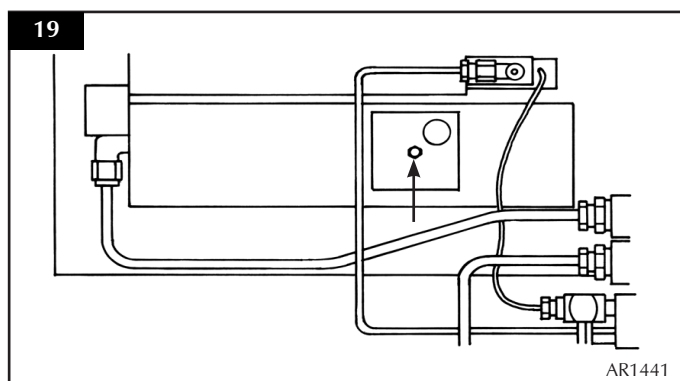

- 10.3 Reassemble in reverse order with the correct aeration plate.

SERVICING INSTRUCTIONS

REPLACING PARTS

11. CHANGING BETWEEN GAS TYPES

In order to change between gas types it will be necessary to change the following items:

- Pilot Unit
- Control Valve**
- Main Injector
- Aeration Plate
- Data Badge

The relevant parts can be ordered from Gazco. Always quote the appliance type and serial number when ordering spare parts.

**** NOTE: THE CONTROL VALVE IS FACTORY PRESET FOR CORRECT GAS TYPE AND MODEL, A NEW UNIT WILL NEED TO BE ORDERED WHEN CHANGING BETWEEN GAS TYPES.**

12. CONTROL UPGRADE

See *Installation Instructions, Installation, Section 1.*

13. BASIC SPARES LIST

	NG	LPG
COMPONENT	G20 20mb	G31 37mb
MAIN INJECTOR	IN0001	IN0054
AERATION PLATE	ME4066	ME4954
PILOT UNIT	PI0036	PI0037
BURNER ASSEMBLY	B0214	PB0214
MAGNETIC UNIT	GC0092	
GAS VALVE	GC0088K**	
IGNITION LEAD	GC0090	
FRONT COAL	CE0122	
FLAME BAFFLE	CE0118	
REAR PANEL	GC0135	
COAL SET	GC0127	
TTB SENSOR	EL0001	
SENSOR LEAD	EL0064	
INTERRUPTER	GC0029	
STANDARD UPGRADE KIT	8455	
THERMO UPGRADE KIT	8456	

**Note: The control valve is factory preset for correct gas type and model.

SERVICE RECORDS

1ST SERVICE

Date of Service:
Next Service due:
Signed:
Retailer's Stamp/Gas Safe Registration Number

2ND SERVICE

Date of Service:
Next Service due:
Signed:
Retailer's Stamp/Gas Safe Registration Number

3RD SERVICE

Date of Service:
Next Service due:
Signed:
Retailer's Stamp/Gas Safe Registration Number

4TH SERVICE

Date of Service:
Next Service due:
Signed:
Retailer's Stamp/Gas Safe Registration Number

5TH SERVICE

Date of Service:
Next Service due:
Signed:
Retailer's Stamp/Gas Safe Registration Number

6TH SERVICE

Date of Service:
Next Service due:
Signed:
Retailer's Stamp/Gas Safe Registration Number

7TH SERVICE

Date of Service:
Next Service due:
Signed:
Retailer's Stamp/Gas Safe Registration Number

8TH SERVICE

Date of Service:
Next Service due:
Signed:
Retailer's Stamp/Gas Safe Registration Number

9TH SERVICE

Date of Service:
Next Service due:
Signed:
Retailer's Stamp/Gas Safe Registration Number

10TH SERVICE

Date of Service:
Next Service due:
Signed:
Retailer's Stamp/Gas Safe Registration Number



A division of Stovax Ltd

Falcon Road, Sowton Industrial Estate, Exeter, Devon, England EX2 7LF

Tel: (01392) 474500 Fax: (01392) 219932

E-mail: yeoman@stovax.com www.yeoman-stoves.co.uk